

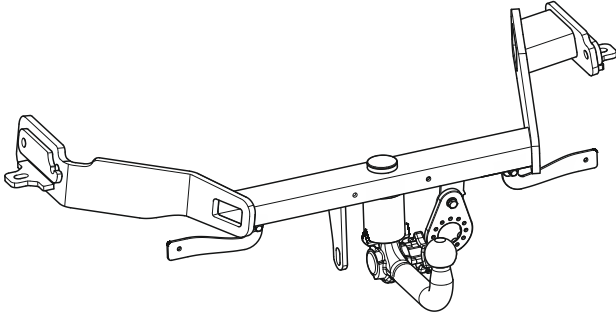

Genuine Accessories developed by MOBIS

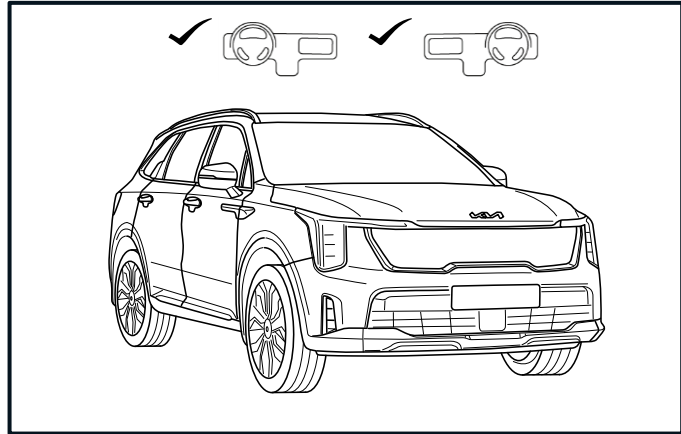

P2281ADE50



Sorento (MQ4-PE, MY 2024-)



P 2/18
P 3/18



P 16/18
P 17/18
P 18/18

E13*55R02/02*4886



P 4/18

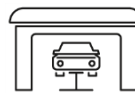
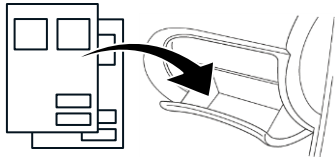
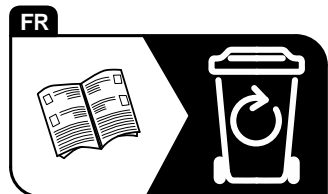

Fig 1.1 - 26
1.5 hrs





(GB)

We expressly point out that assembly not carried out properly by a competent installer will result in cancellation of any right to damage compensation, in particular those arising by virtue of the product liability act.

Contents of these kits and their fitting manuals are subject to alteration without notice, please ensure that these instructions are read and fully understood before commencing installation.

(F)

Nous tenons à insister tout particulièrement sur le fait que si ce produit n'est pas correctement assemblé par un technicien compétent, aucun droit de compensation ne sera recevable en cas de dommages, notamment les droits en vertu de la loi concernant la responsabilité à l'égard des produits.

Le contenu de ce produit, ainsi que des guides de montage qui les accompagnent est sujet à modifications sans préavis; lisez attentivement ces instructions avant de procéder à l'installation.

(D)

Beachten Sie bitte, dass bei Schäden in Folge unsachgemäßen Einbaus sämtliche Garantieansprüche erlöschen.

Das Recht zu Änderungen an Inhalt von Montagesatz und Einbauanleitung ohne Vorankündigung bleibt vorbehalten. Lesen Sie vor dem Einbau diese Anleitung sorgfältig durch.

(E)

Una vez más, hacemos hincapié en el hecho de que si este producto no es instalado correctamente por un técnico cualificado, se anulará cualquier derecho de compensación por posibles daños, especialmente los relativos a la legislación vigente sobre este tipo de productos.

El contenido de los kits y sus correspondientes manuales de montaje están sujetos a posibles modificaciones sin previo aviso. Es importante que lea con atención todas las instrucciones y que las entienda perfectamente antes de iniciar la instalación.

(PT)

Salientamos expressamente que a montagem não realizada por um instalador competente resultará no cancelamento de quaisquer direitos a compensações por danos, particularmente dos resultantes ao abrigo da lei sobre responsabilidade de produtos. O conteúdo destes kits e os respetivos manuais de instalação estão sujeitos a alteração sem aviso prévio. Certifique-se de que estas instruções são lidas na íntegra e compreendidas antes de se iniciar a instalação.

(I)

Vi informiamo che, in caso di installazione scorretta e/o non eseguita da un installatore competente, il Cliente perderà ogni diritto a un eventuale rimborso danni e, specificamente, ogni diritto previsto dalle leggi sulla responsabilità di prodotto.

I contenuti di questi kit e i relativi manuali di installazione sono soggetti a modifica senza preavviso. Si raccomanda di leggere attentamente e integralmente tali istruzioni e di sincerarsi di averle comprese prima di procedere all'installazione.

(NL)

De installatie moet worden uitgevoerd door een erkende, competente installateur. Incorrecte montage kan leiden tot het vervallen van elk recht op schadecompensatie, met name die met betrekking tot product aansprakelijkheid.

De inhoud van deze kits en de installatiehandleidingen kunnen worden gewijzigd zonder kennisgeving. Zorg er voor, dat u deze instructies hebt gelezen en volledig begrijpt voordat u met de installatie begint.

(S)

Vi meddelar att montering, som inte görs fackmannamässigt, kommer att häva rätten till kompensation för skador, speciellt rättigheter enligt lagen om produktansvar.

Innehållet i dessa satsar och deras bruksanvisningar kan komma att ändras utan förvarning. Vänligen läs dessa anvisningar noga innan du påbörjar monteringen.

(N)

Vi bemerker at montasje som ikke utføres korrekt, av en kompetent installatør, vil resultere i annullering av all rett til erstatning for enhver skade, spesielt de som oppstår av arten produktansvar.

Innholdene i disse sett og deres monteringsanvisninger kan endres uten forvarsel. Vennligst påse at disse instruksjonene leses grundig og er forstått innen installasjonen startes.

(DK)

Det skal understreges, at montering, der udføres af en ikke-kvalificeret montør, medfører bortfald af enhver ret til erstatning særligt i forbindelse med erstatningskrav, der måtte opstå i kraft af loven om produktansvar.

Sætnenes indhold og monteringsvejledninger kan ændres uden varsel, og vejledningerne skal derfor læses og forstås, før monteringen påbegyndes.

(FIN)

Jos asennuksen suorittaa joku muu kuin pätevä ammattilainen, tämä kumoo asiakkaan oikeuden vahingonkorvauksiin, erityisesti sellaisiin, jotka perustuvat tuotevastuulakiin.

Kiinnityssarjan sisältöä ja asennusohjeita voidaan muuttaa siitä etukäteen ilmoittamatta. Näihin ohjeisiin tulee perehtyä huolellisesti ennen asennuksen aloittamista.

(CZ)

Upozorňujeme, že instalace provedená nesprávně nebo nekompetentní osobou, ruší veškerá práva na kompenzaci škod, obzvláště teh způsobených poruchou produktu.

Obsah těchto sad a návody na jejich montáž podléhají změně bez předchozího upozornění. Prosím, ujistěte se, že jste si pokyny před instalací přečetly a dostatečně jim rozumíte.

(PL)

Pragniemy wyraźnie podkreślić, że nieprawidłowy montaż przeprowadzony przez niekompetentne osoby będzie podstawą rezygnacji z ewentualnego prawa do odszkodowania, w szczególności wynikających z mocy ustawy o odpowiedzialności za produkt.

Zawartość opisywanych zestawów i instrukcje ich montażu mogą ulec zmianie bez uprzedzenia; przed rozpoczęciem instalacji należy zapoznać się z instrukcjami i upewnić się, że zostały w pełni zrozumiałe.

(SK)

Upozorňujeme, že inštalácia vykonaná nesprávne alebo nekompetentnou osobou, ruší všetky práva na kompenzáciu škôd, obzvlášť tých spôsobených poruchou produktu.

Obsah týchto sad a návody na ich montáž podliehajú zmenám bez predchádzajúceho upozornenia. Prosím, uistite sa, že ste si pokyny pred inštaláciou prečítali a dostatočne ste im porozumeli.

(RO)

Vă atragem atenția că montajul efectuat incorect sau de către personal neautorizat duce la anularea oricărui drept de compensare a eventualelor daune produse utilizatorului.

Conținutul acestor pachete precum și al instrucțiunilor de montaj pot fi modificate fără preaviz. Vă rugăm să vă asigurați că aceste instrucțiuni sunt citite și înțelese înainte de a începe instalarea.

(BG)

Изрично посочваме, че при монтиране, което не се осъществява правилно от компетентен монтьор, ще последва отмяна на всякакви права за обезщетение за нанесени вреди, по-специално тези, произтичащи въз основа на закона за отговорност за вреди. Съдържанието на тези комплекти и техните монтажни ръководства подлежат на изменения без предизвестие. Моля, уверете се, че инструкциите са прочетени и напълно разбрани преди започване на монтажната дейност.

(EST)

Juhime tähelepanu sellele, et ebakorrektnete ja ebapädeva paigaldaja tehtud montaaž tühistab õiguse esitada kahjunõudeid, eelkõige tootevastutusseaduse alusel esitatavaid nõudeid.

Nende komplektide ja paigaldusjuhendite sisu võidakse ette teatamata muuta, mistõttu tuleb juhised enne paigalduse alustamist läbi lugeda ja neist täielikult aru saada.

(HR)

Izričito naglašavamo da će montaža koju ne provodi ovlaštena instalater rezultirati otkazivanjem svih prava na naknadu štete, osobito onih koja se temelje na zakonskim propisima o odgovornosti za proizvode. Sadržaj ovih kompleta i njihovih priručnika za pričvršćivanje podložni su izmjeni bez prethodne obavijesti, pažljivo pročitajte s razumijevanjem ove upute prije započinjanja s instalacijom.



www.mobisparts.eu



(HU)

Kifejezetten felhívjuk a figyelmét, hogy a nem megfelelően, hozzáértő szakember által végzett összeszerelés a kártérítésre vonatkozó valamennyi jog elvesztését eredményezi, különös tekintettel a termékgaranciáról szóló törvények biztosította jogokra. A készletek és a felhelyezési útmutatók tartalma külön értesítés nélkül változhat, ezért a szerelés megkezdése előtt mindenképp gondosan tanulmányozza át és értelmezze az utasításokat.

(LAT)

Mēs īpaši norādām uz to, ka gadījumos, kad aplīmēšanu nebūs pareizi veicis kompetents tehniķis, jebkādas tiesības uz zaudējumu atlīdzību tiks anulētas, jo īpaši tādas, ko pamato produktu drošumatbildības likums. Šo komplektu un to uzlīmēšanas rokasgrāmatu saturs var tikt mainīts bez iepriekšēja paziņojuma, lūdzu, nodrošiniet, lai pirms līmēšanas sākšanas šie norādījumi būtu izlasīti un pilnībā izprasti.

(LIT)

Mes aiškiai nurodome, kad, jei montavimas nėra tinkamai atliktas kompetentingo montuotojo, nesuteikiamos jokios teisės į žalos kompensavimą, ypač tos, kurios išplaukia iš gaminio atsakomybės akto. Šių rinkinių turinys ir jų įrengimo vadovai gali būti keičiami nepranešus, užtikrinkite, kad prieš pradėdant įrengimo darbus būtų perskaitytos ir visiškai suprastos šios instrukcijos.

(SER)

Posebno ističemo da će montaža koju nije obavio kvalifikovani montažer, imati za posledicu poništavanje svih prava na obeštećenje, a posebno onog koje proističe iz odluke o odgovornosti za proizvod. Sadržaj ovih kompleta i pripadajućih uputstava podleže izmenama bez upozorenja, molimo vas da se postarate da se ova uputstva pročitate i u potpunosti razumeju pre početka instalacije.

(SVN)

Izrecno opozarjamo, da bo montaža, ki ne bo izvedena ustrezno s strani pristojnega monterja, povzročila razveljavitev kakršnih koli pravic do odškodnine, zlasti tistih, ki izhajajo iz zakona o odgovornosti za izdelek. Vsebina kompletov in priročnikov za vgradnjo je predmet sprememb brez predhodnega obvestila. Prepričajte se, da bodo izvajalci pred pričetkom vgradnje navodila prebrali in razumeli.

(UKR)

Наголошуємо на тому, що роботи мають здійснюватися належним чином і виключно вповноваженим виконавцем. В іншому випадку будь-які права на відшкодування збитків, зокрема ті, які виникають згідно із законодавством про відповідальність виробника за якість продукції, вважаються недійсними. Вміст цих комплектів і відповідні інструкції можуть бути змінені без попередження. Не розпочинайте роботи, якщо ви не прочитали та не зрозуміли повною мірою ці інструкції.

(ICE)

Við bendum gagngert á að ef samsetningin er ekki almennilega gerð af aðila sem er með viðeigandi þjálfun getur rétturinn á skaðabótum vegna skemmda, sérstaklega skaðabótum varðandi reglur um vöruábyrgð, orðið ógildur. Innihaldið settanna og uppsetningarleiddbeiningar geta breyst án fyrirvara. Vinsamlegast tryggjið að þessar leiddbeiningarnar séu lesnar og fullur skilningur til staðar áður en uppsetning hefst.

(GR)

Θα πρέπει να τονιστεί ότι συναρμολόγηση που δεν πραγματοποιείται σωστά και από ειδικευμένο εγκαταστάτη οδηγεί σε ακύρωση των όποιων δικαιωμάτων αποζημίωσης έναντι ζημίας και ιδιαίτερα αυτών που προκύπτουν σύμφωνα με το νόμο περί ευθύνης προϊόντος. Τα περιεχόμενα αυτών των kit και τα εγχειρίδια τοποθέτησης υπόκεινται σε αλλαγές χωρίς προειδοποίηση. Βεβαιωθείτε ότι ο οδηγός και αυτές έχουν διαβαστεί και έχουν γίνει απολύτως κατανοητές προτού ξεκινήσετε την εγκατάσταση.

(RUS)

Обратите внимание, что при повреждениях, возникших в результате неправильного монтажа, истекают все виды гарантии, в частности, касающиеся закона, регулирующего ответственность за качество продукции. Производитель сохраняет за собой право на изменение содержания монтажного комплекта и инструкции по установке без предварительного уведомления. Внимательно прочитайте инструкцию перед началом установки.



www.mobisparts.eu

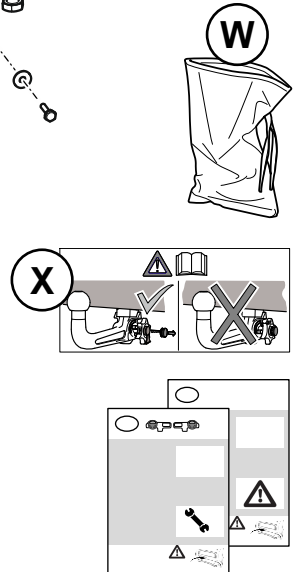
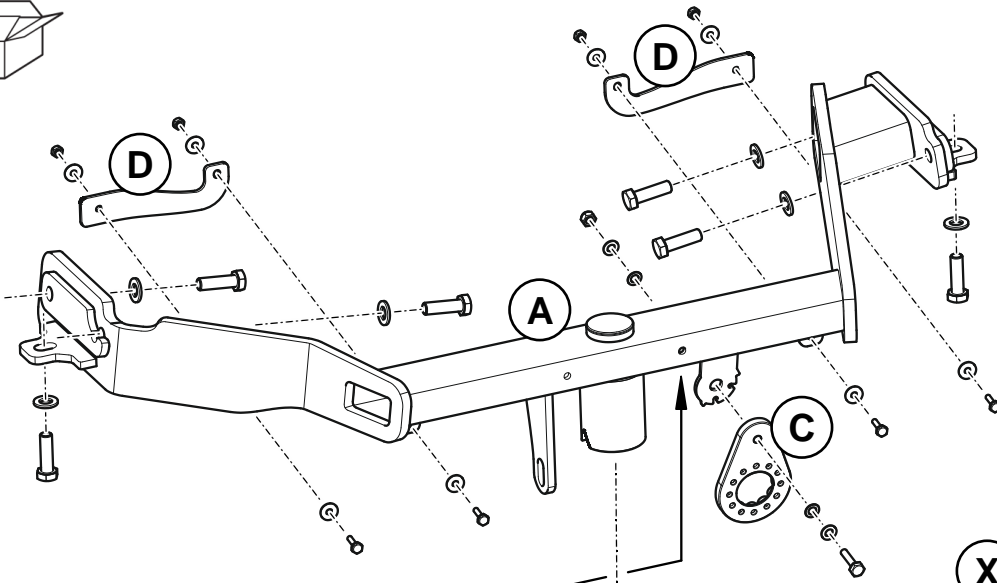
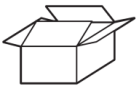

KIA

COUPLING CLASS **A50-X**

APPROVAL NUMBER **E13** 55 R-02 4886

PART NO. **P2281ADE50** D **13,0** kN

PART NO. **345177600001** S **100** kg

SUPPLIER

TYPE NO. **KIR69H** SERIAL NO. _____

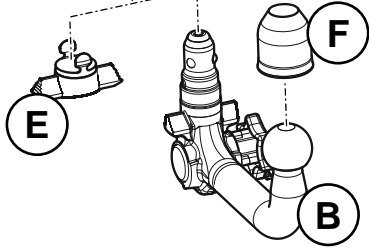

- | | | | | | | | |
|--|-----------------|--|--------|--|-----|--|-----|
| | 6 × M12×1,25×40 | | 2 × Ø8 | | 2 × | | 1 × |
| | 1 × M8×30 | | 1 × M8 | | | | 1 × |
| | 4 × M6×20 | | 4 × M6 | | 1 × | | 1 × |
| | 6 × Ø13×24×2,5 | | 2 × | | 1 × | | |
| | 2 × Ø8,4×16×1,6 | | 1 × | | | | |
| | 8 × Ø6,4×18×1,6 | | | | | | |

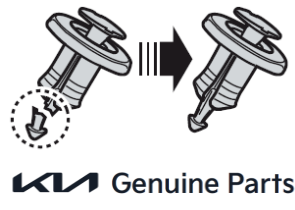
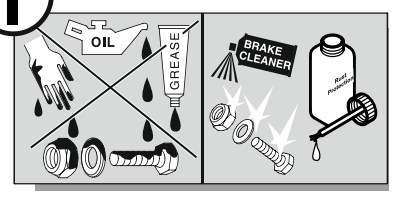
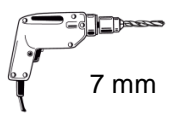
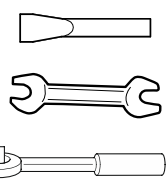
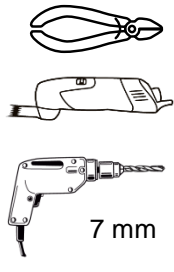
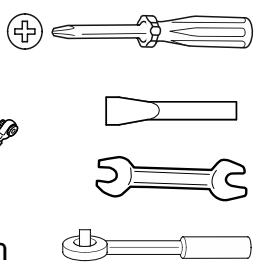

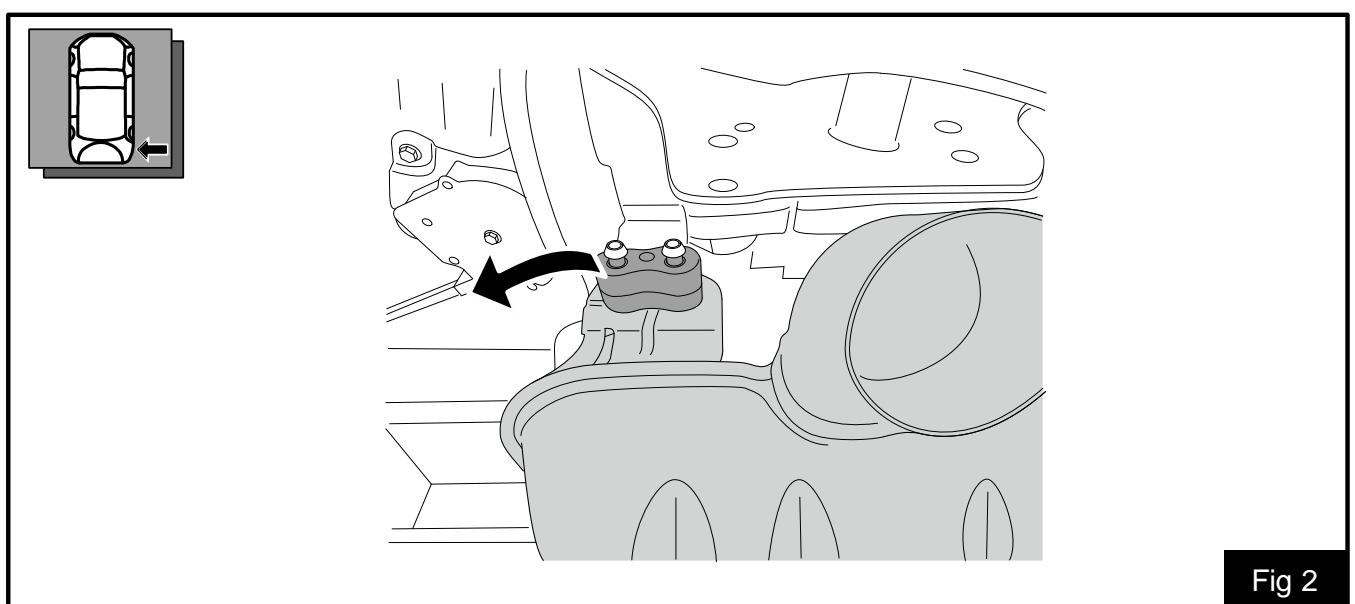
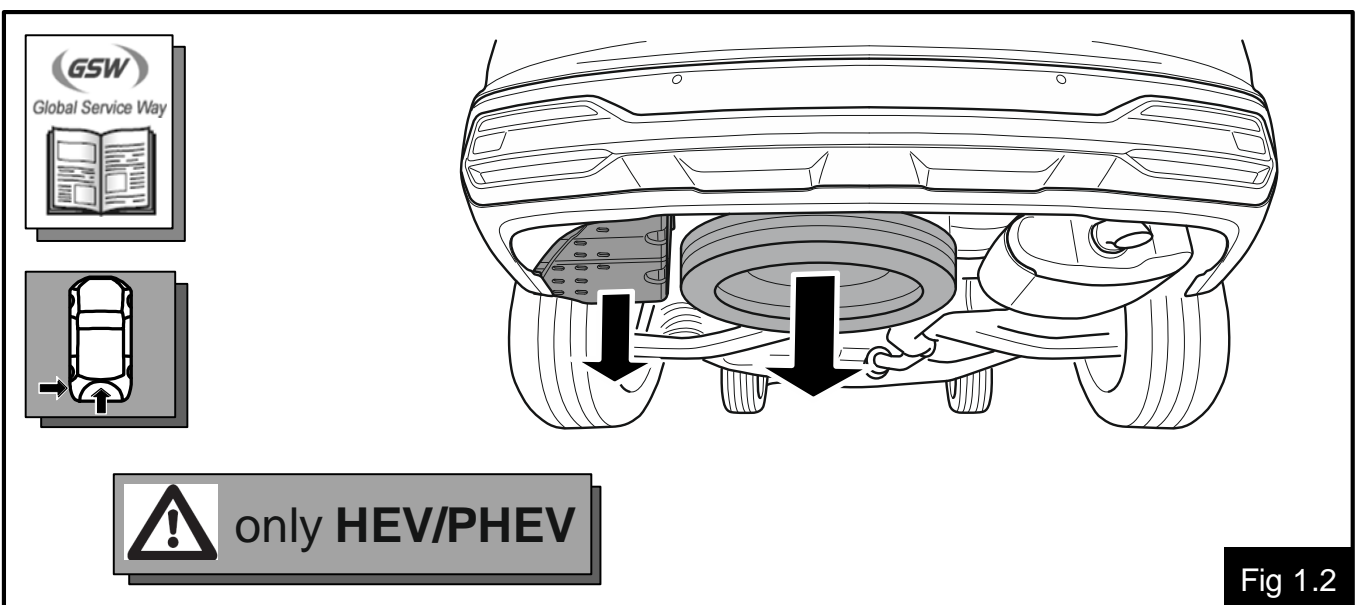
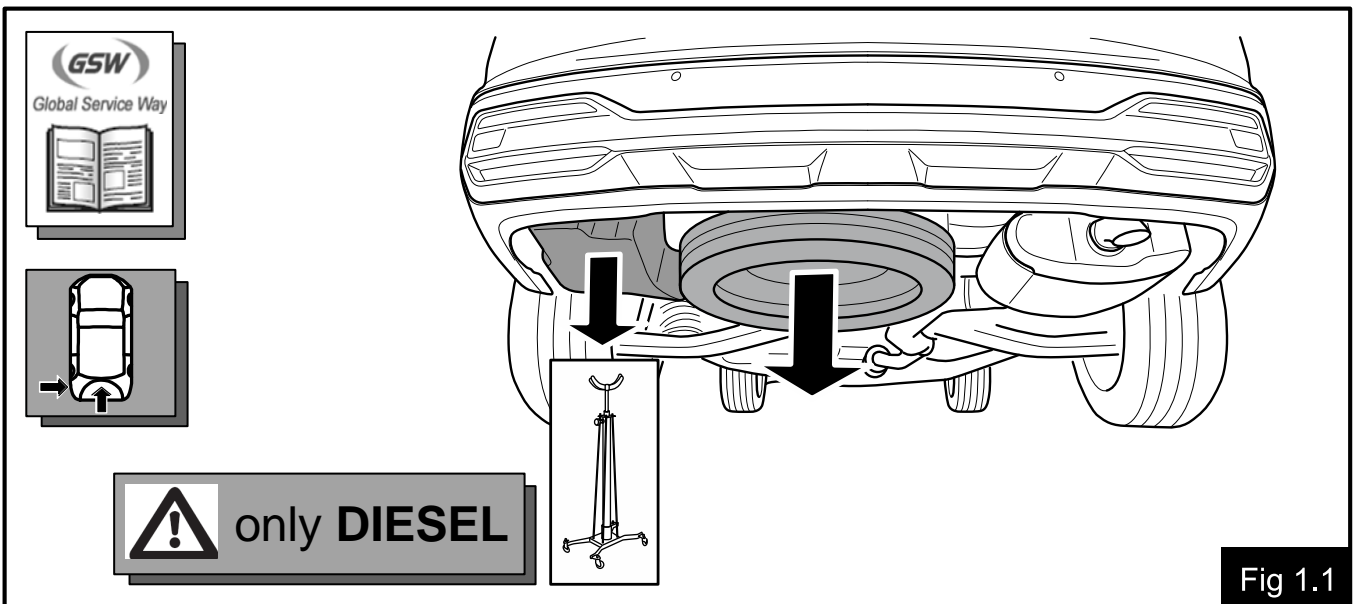

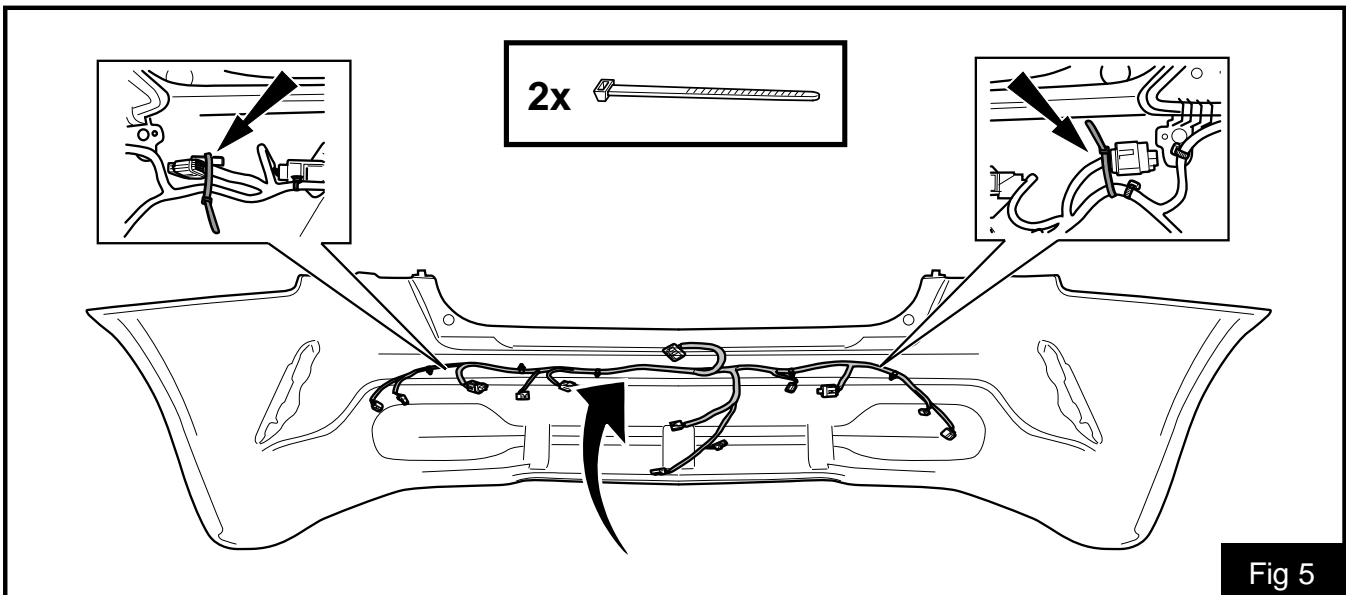
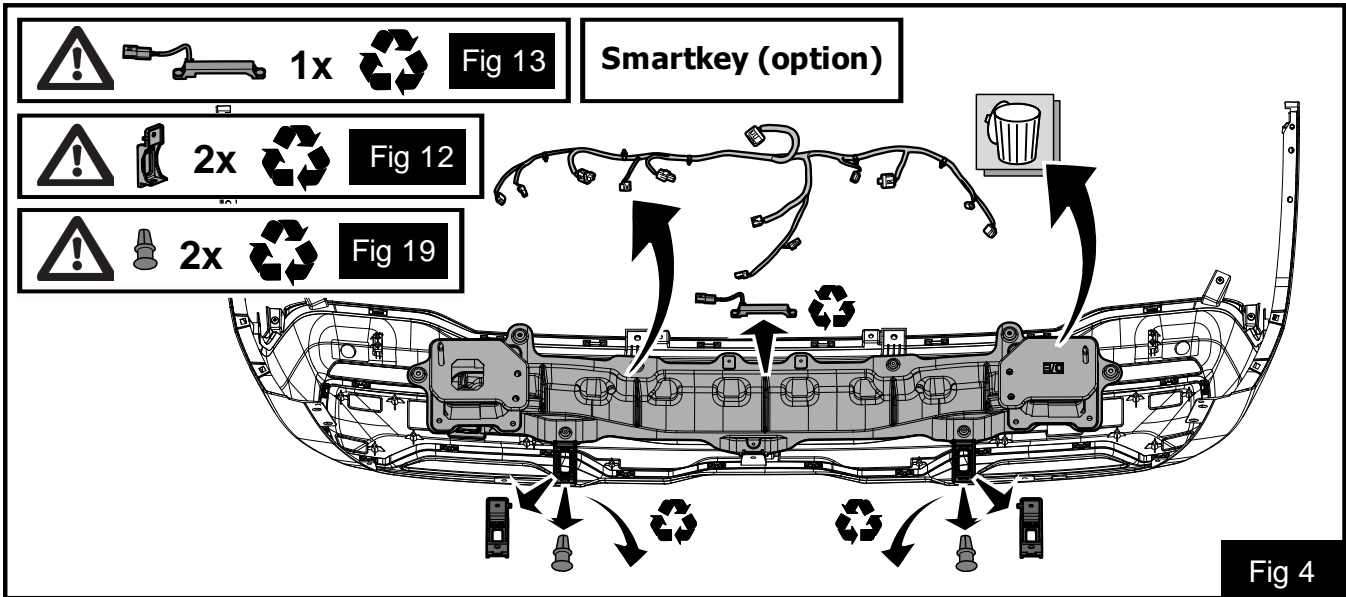
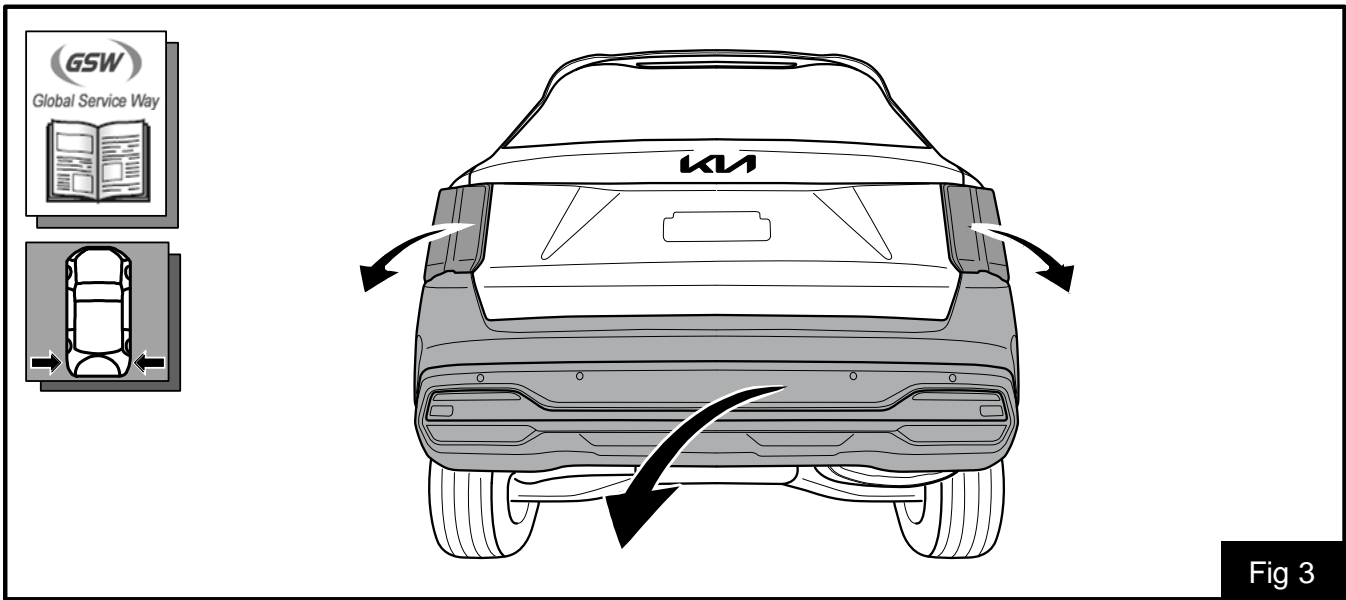

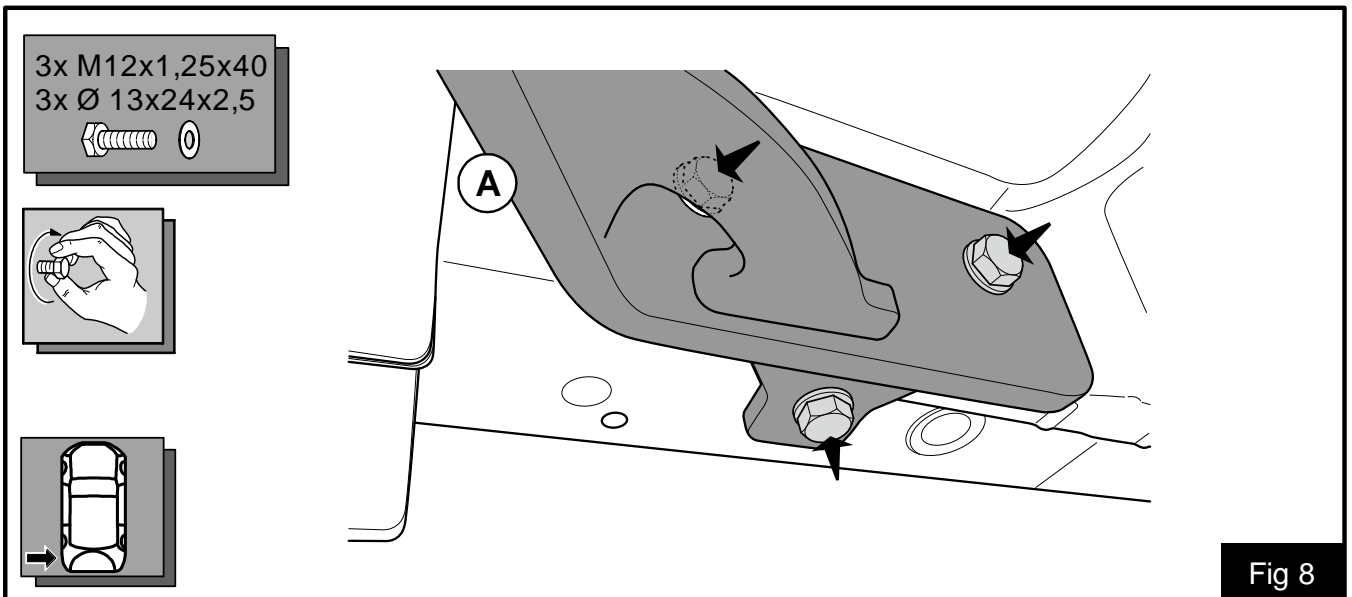
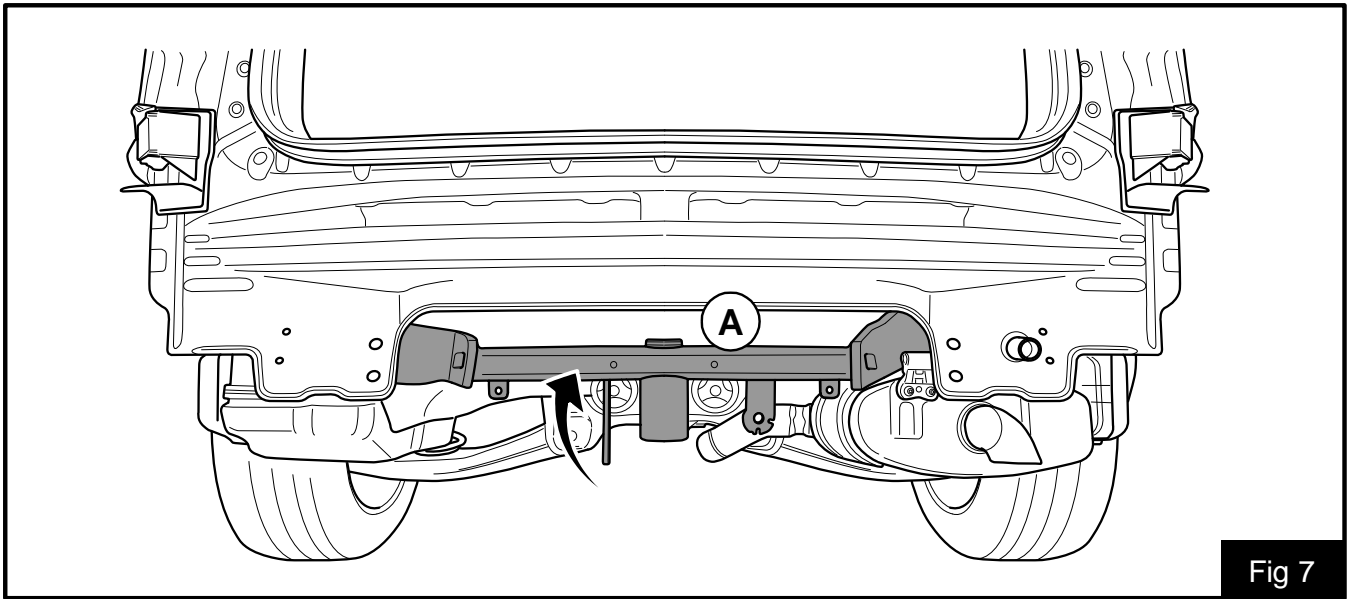
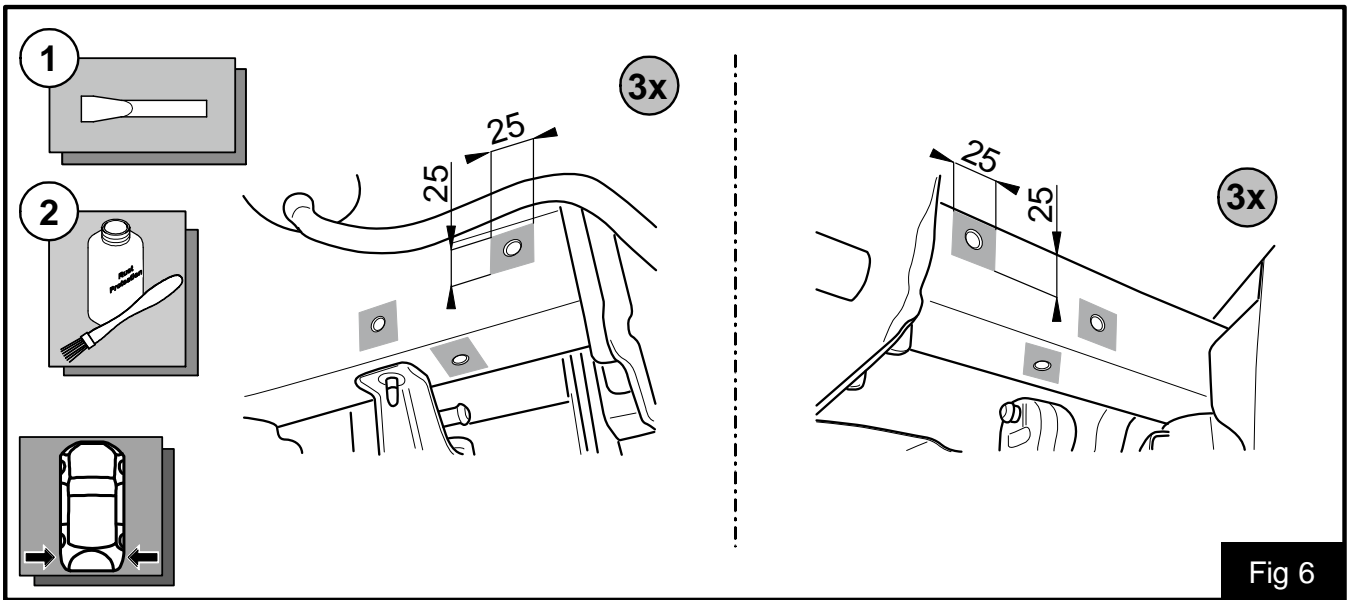



3x M12x1,25x40
3x Ø 13x24x2,5

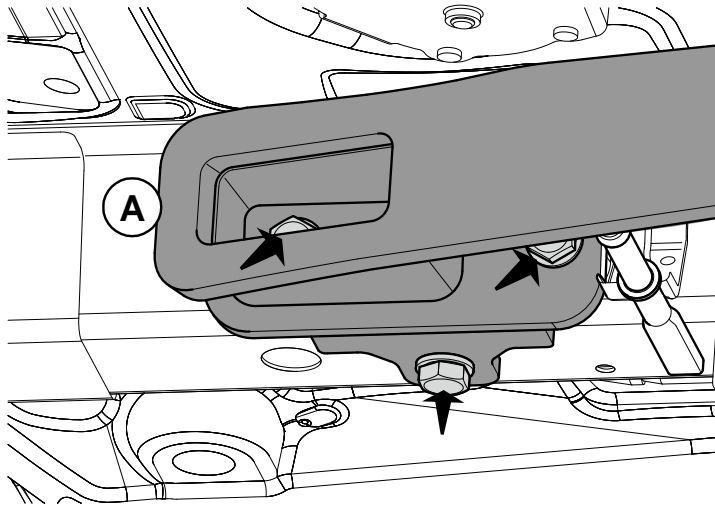
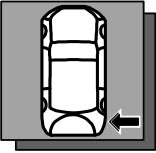
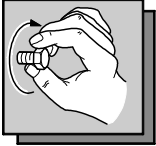

Fig 9



M12x1,25x40 → 95 Nm

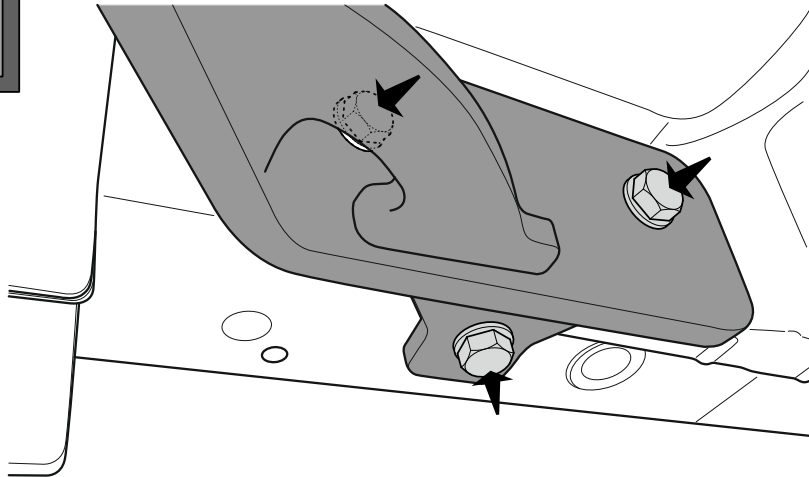
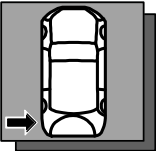

Fig 10



M12x1,25x40 → 95 Nm

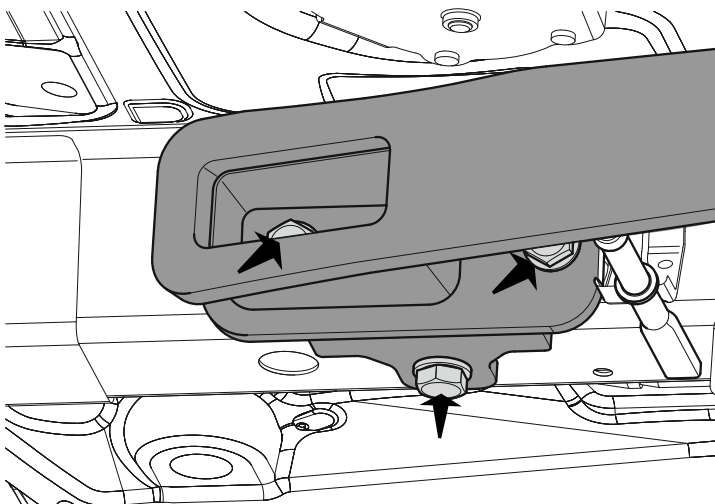
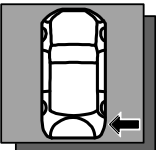

Fig 11

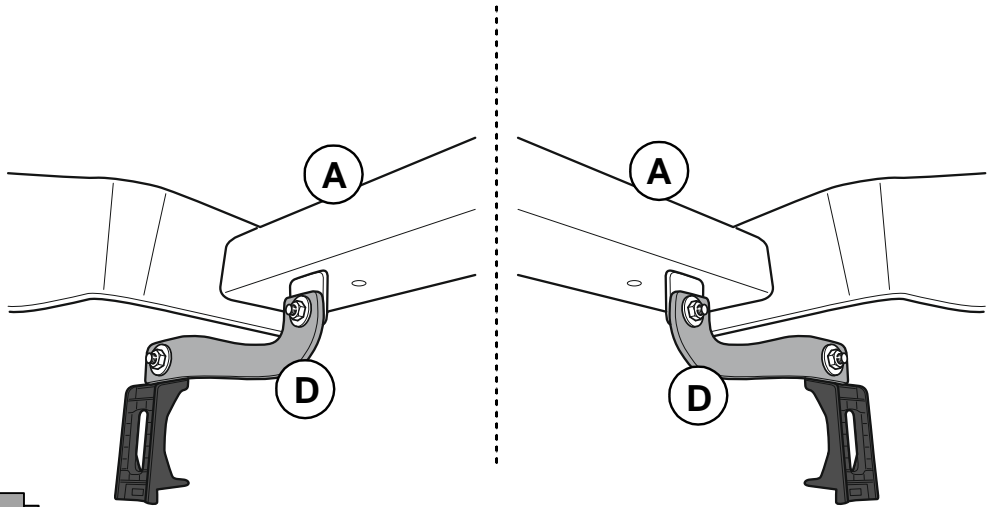
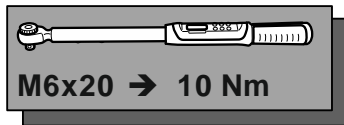
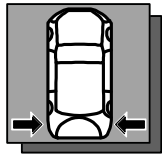
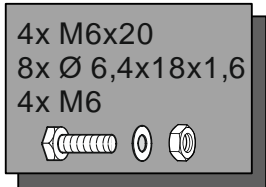
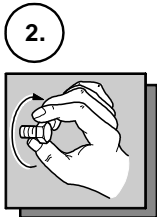
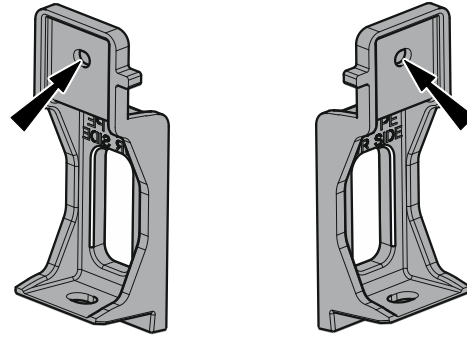
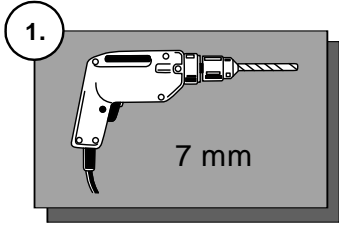

Fig 12

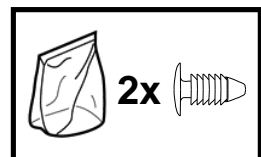
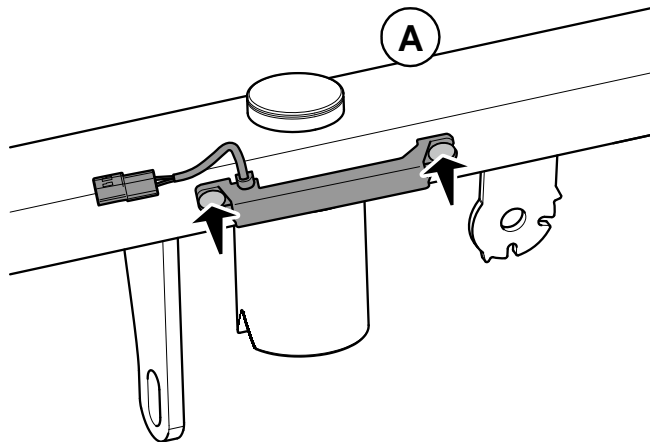
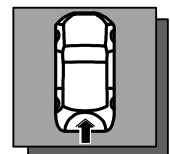

Fig 13

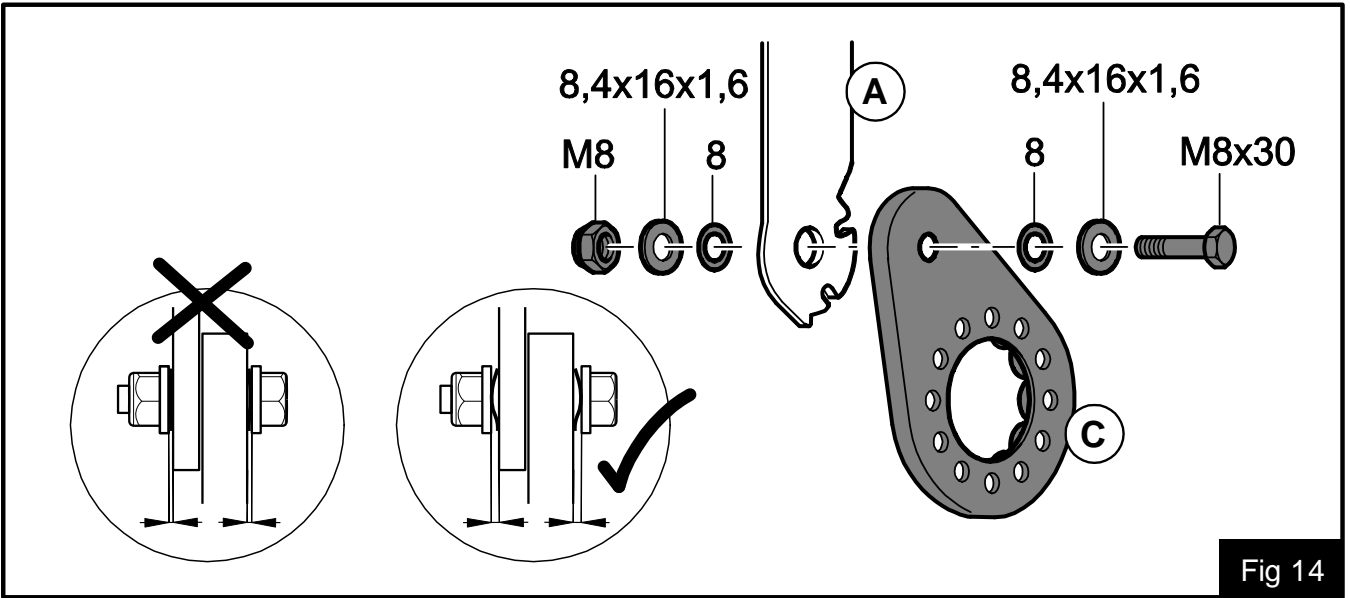

Fig 14

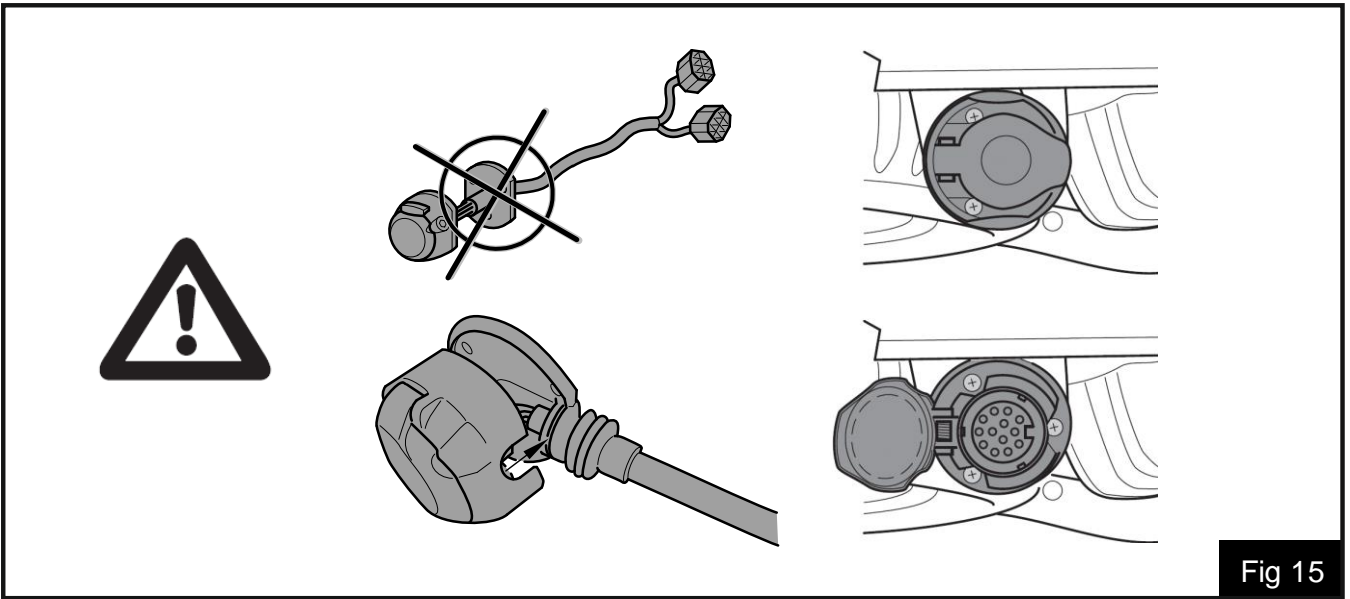

Fig 15

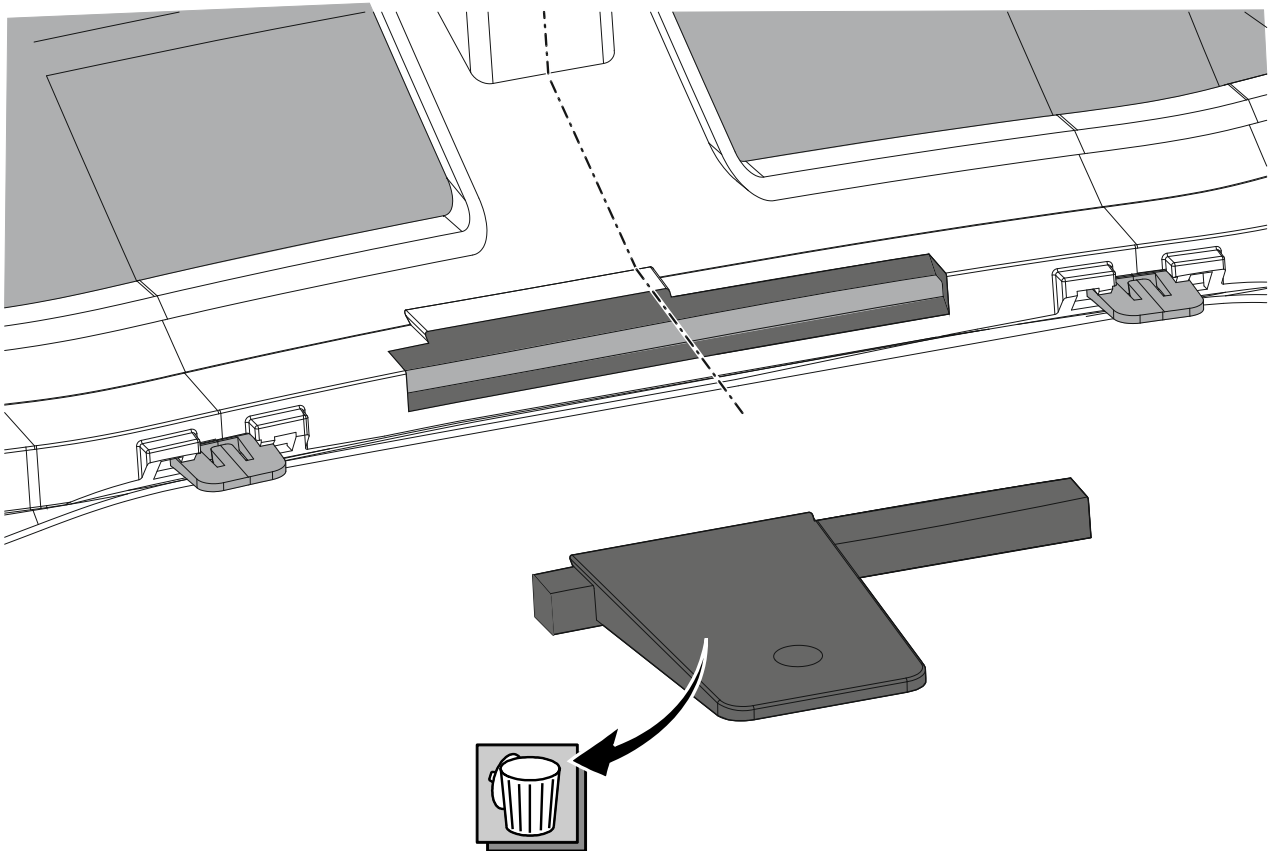
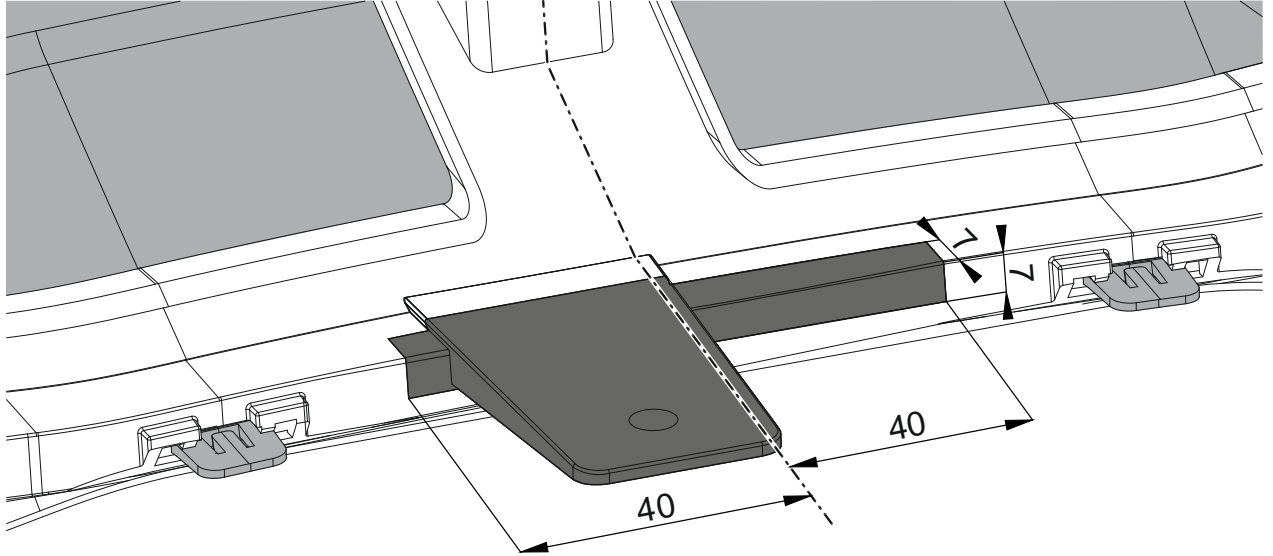
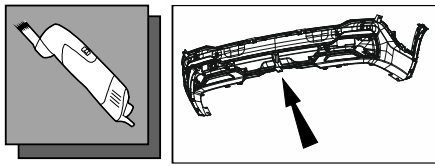

Fig 16

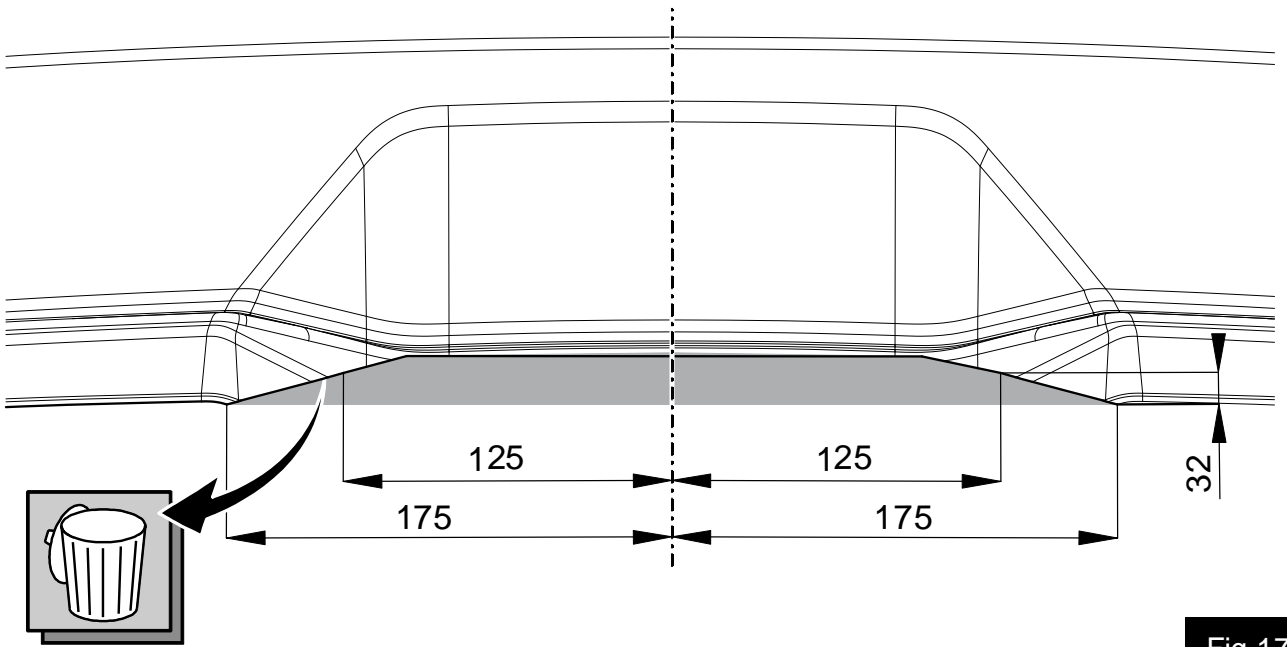
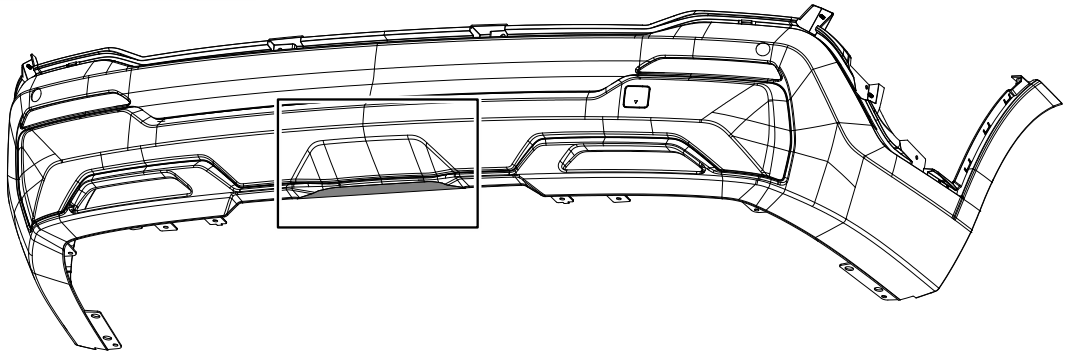
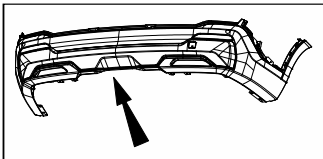
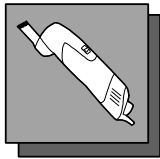

Fig 17

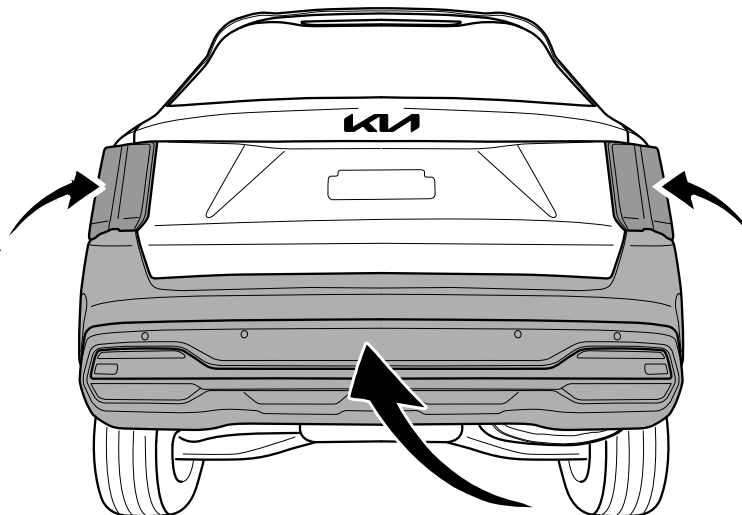
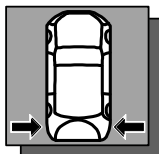

Fig 18

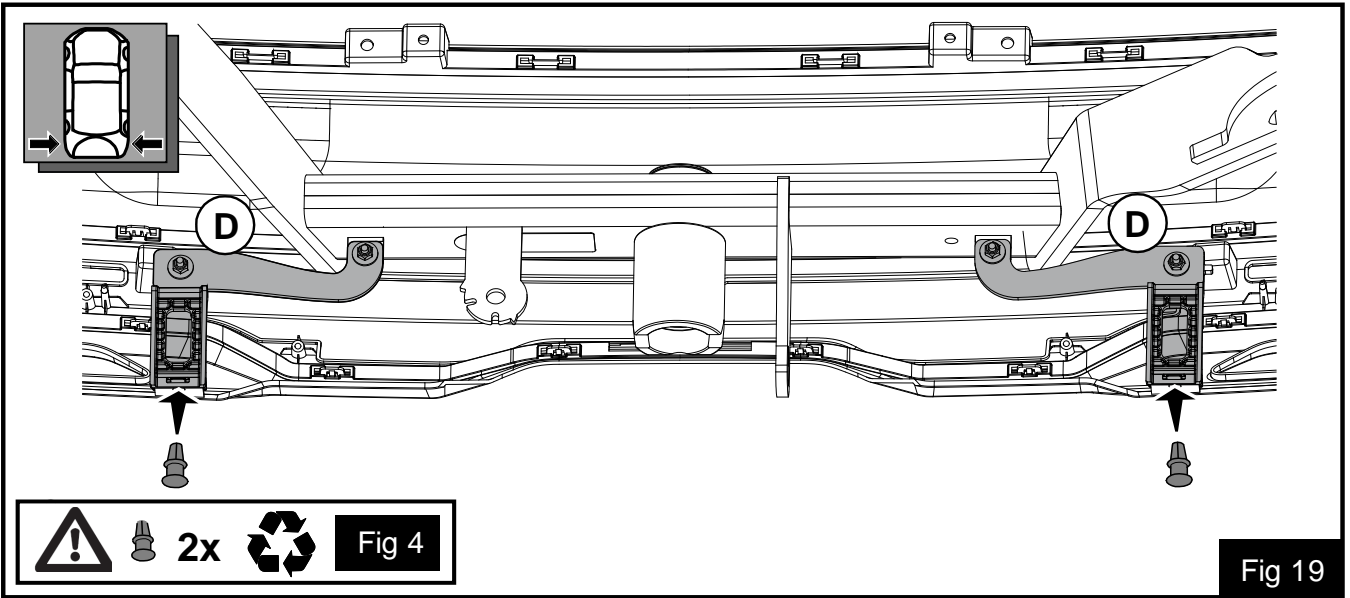

Fig 19

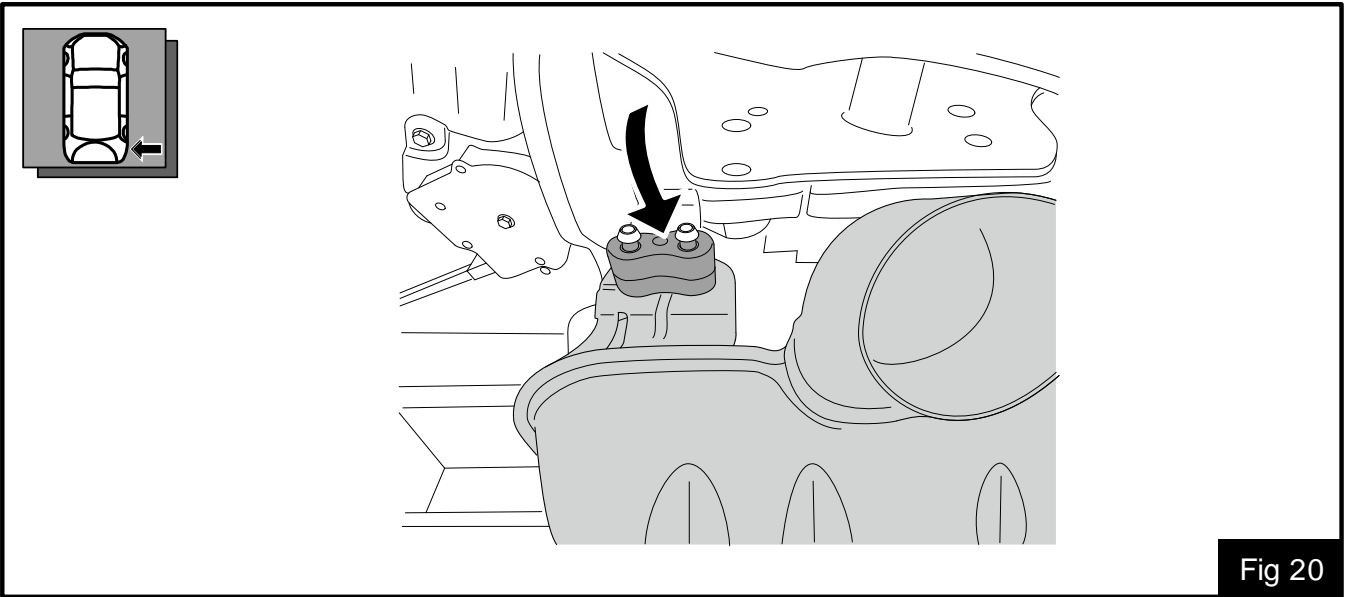

Fig 20

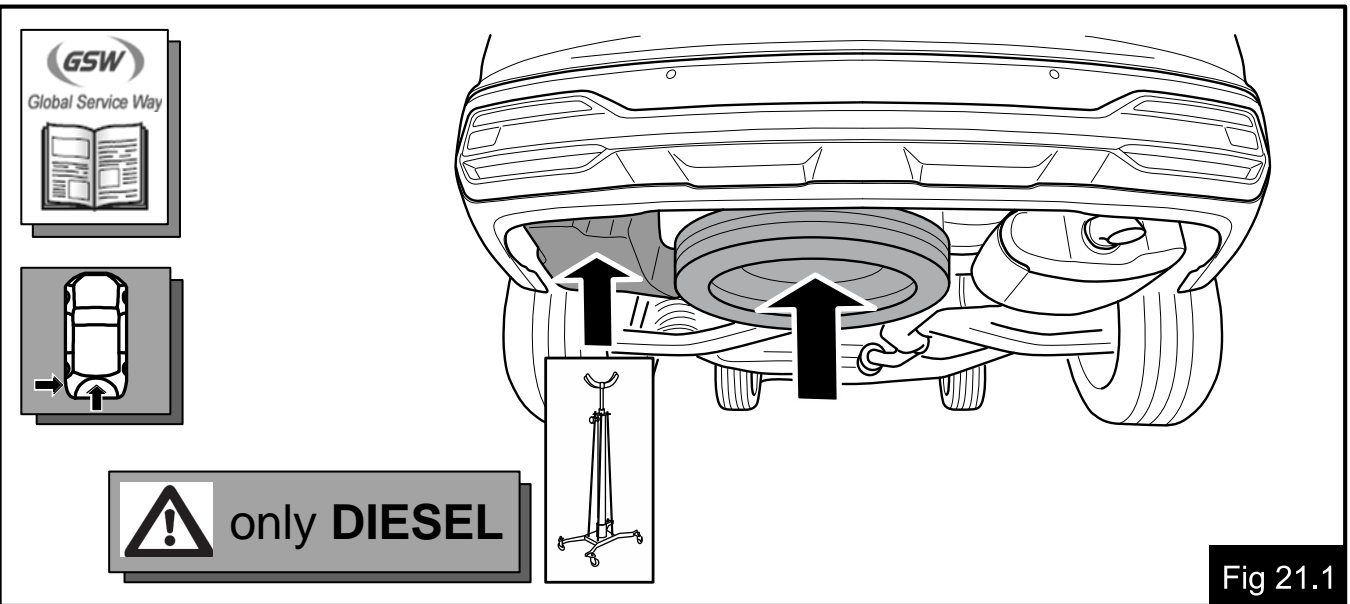
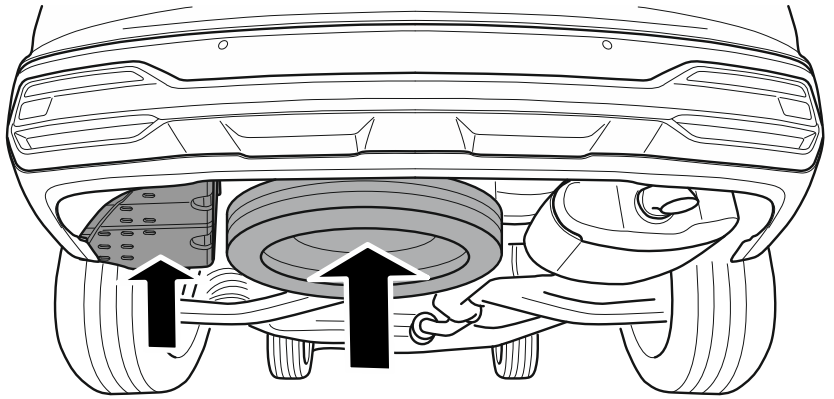
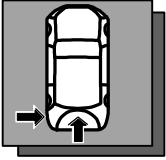

Fig 21.1



 only HEV/PHEV

Fig 21.2

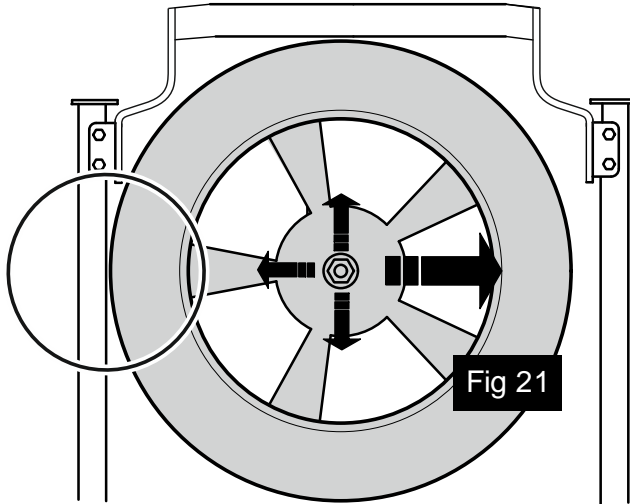

Fig 21

Fig 22

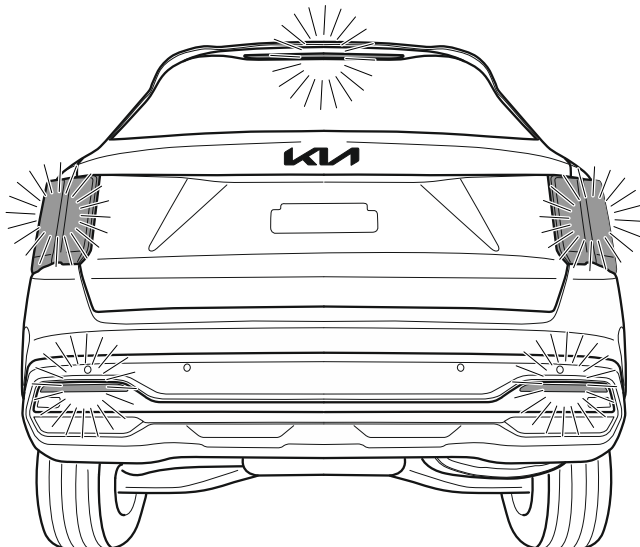

Fig 23

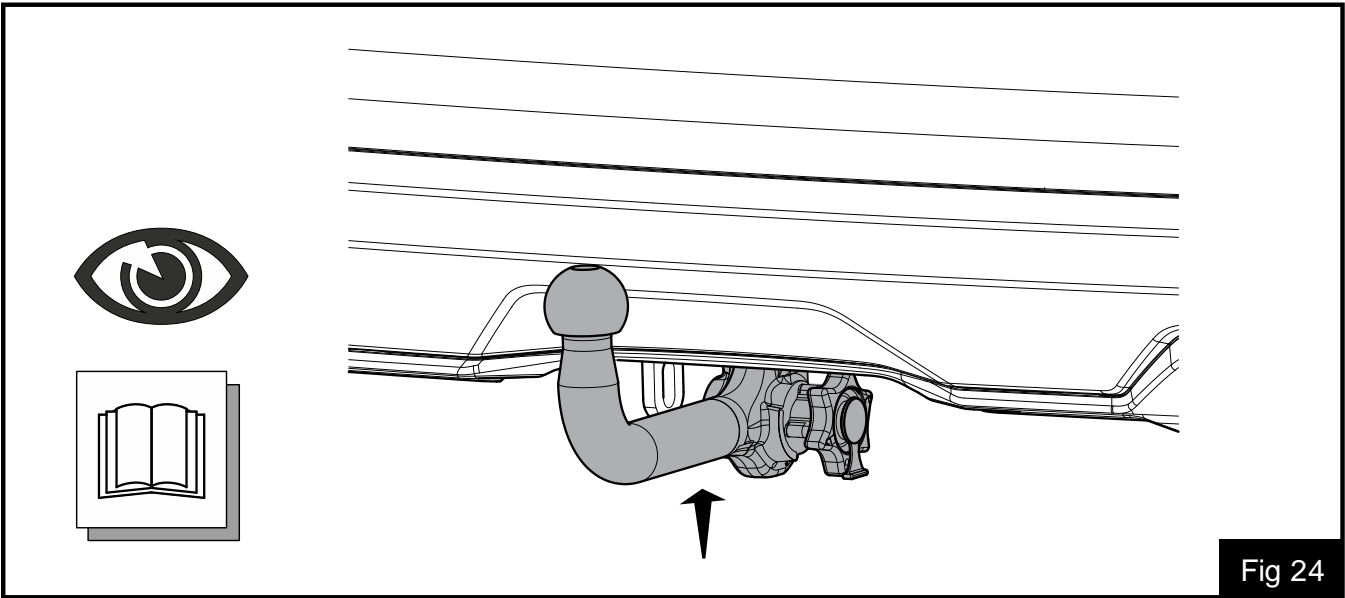

Fig 24

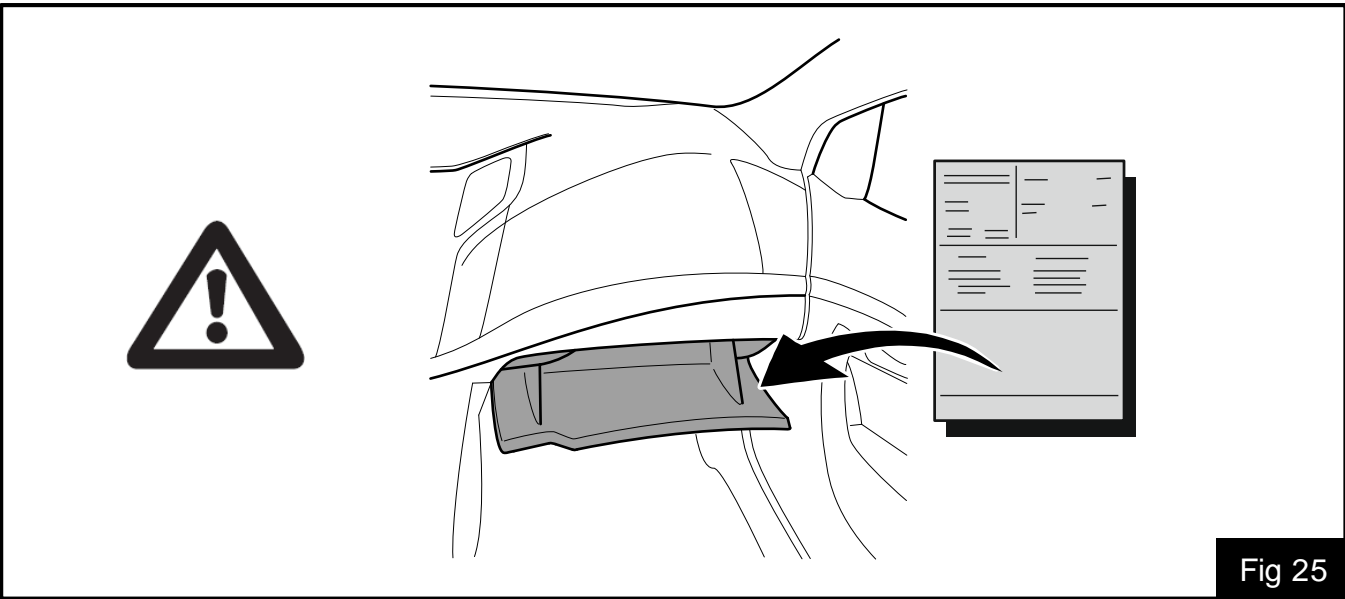

Fig 25

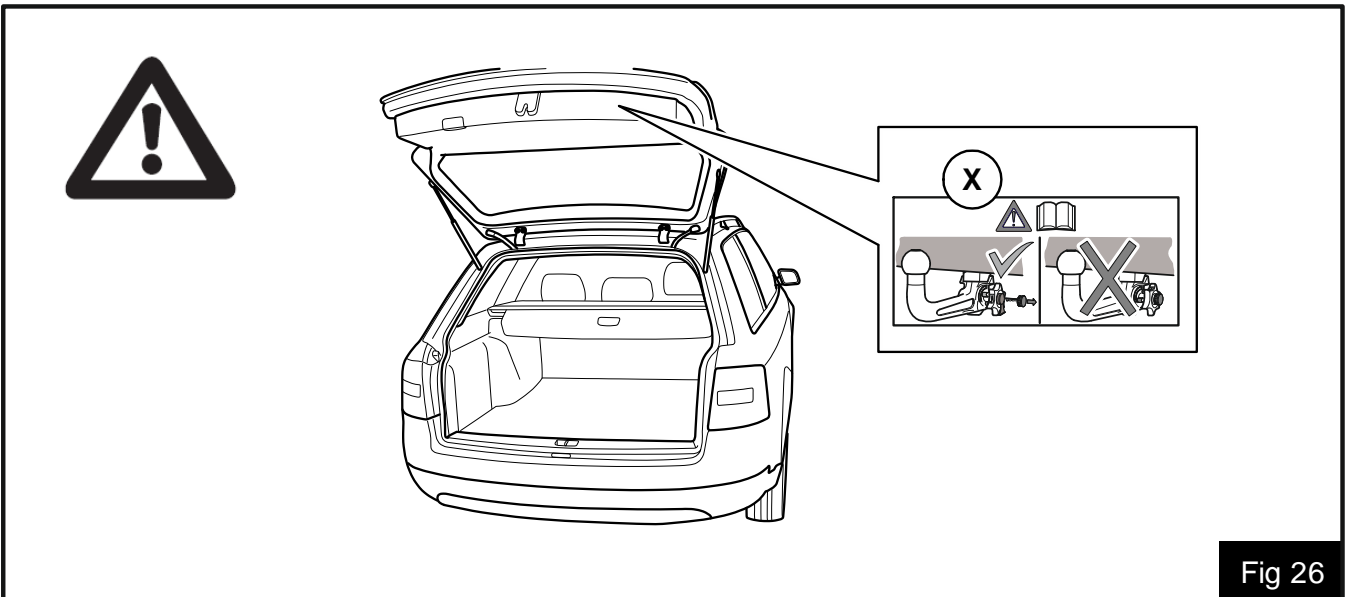
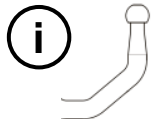

Fig 26



Nm

Model name, year of introduction	KIA	Sorento	MY 2024 -
Vehicle type, Variant, Version	MQ4	?????	??????
Type name	KIR69H	Vehicle Identification Number (VIN) ???)???)???)???)???)???)???)???)	
MOBIS Part number	P2281ADE50	Class of device A50-X	
Approval number	E13*55R02/02*4886	ECE Regulation N° 55 / ECE-R55	
D-value	13,0 kN		
Max. static mass on coupling ball	100 kg		
Max. towable trailer mass	? kg	Consult vehicle manual!	

1 ? kg

2 ? kg

3

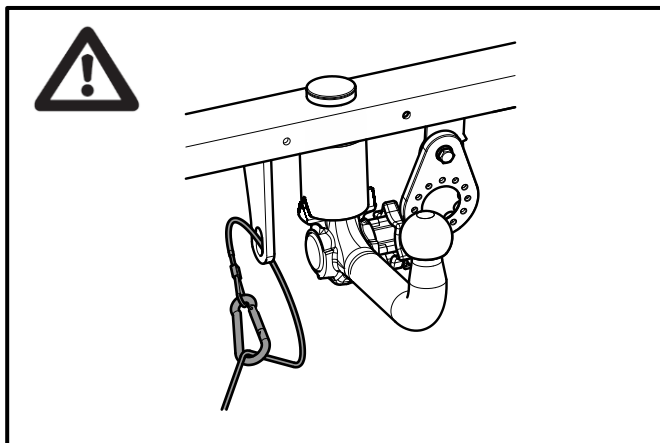

+ = max. 75 kg
max. 3

E823055001 = 13,5 kg

max. km/h
max. mph

max.
↓

max.
↓

max.
↓

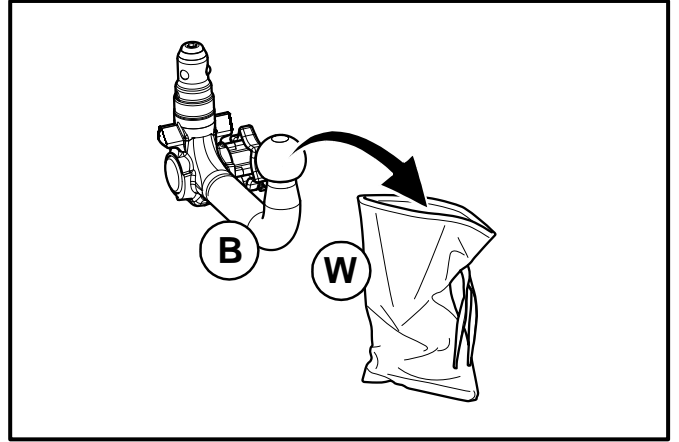
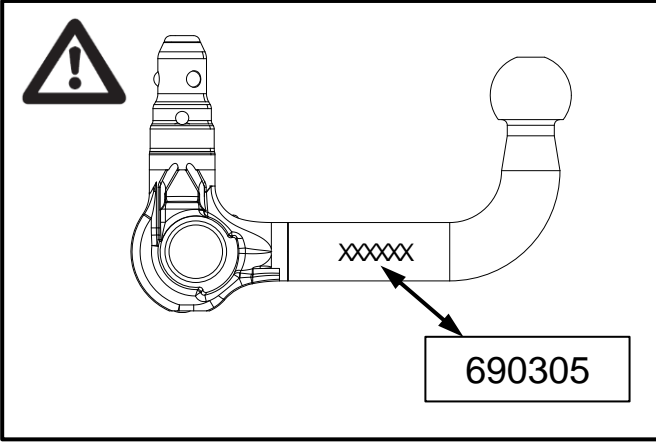



Dispositivo di traino tipo: **KIR69H**
 Per autoveicoli: **KIA Sorento MY 2024 -**
 Tipo funzionale: **MQ4**
 Classe e tipo di attacco: **CLASS A50-X**
 Omologazione: **E13*55R02/02*4886**
 Valore D: **13,0 kN**
 Carico verticale max. S: **100 kg**
 Larghezza rimorchiabile per Caravan e T.A.T.S.: **2,45 m vedere CARTA di CIRCOLAZIONE VEICOLO (motrice) + 70 cm = arrotondare ai 5 cm superiore (vedi D.M. 28/05/85)**
 Massa rimorchiabile: **Vedi carta circolazione dell' autoveicolo**



Per verificare l'idoneità del dispositivo di traino omologato a norma ECE-R55, all'installazione sulla vettura su cui si intende procedere al montaggio, compilare la seguente formula (se necessario declassare la massa rimorchiabile):

$$D = ((T \times C) / (T + C)) \times 0,00981 = 13,0 \text{ kN} < D$$

dove:
 T = Massa Complessiva Max. della motrice (in kg)
 C= Massa Rimorchiabile Max. della motrice (in kg)

DA COMPILARE PER IL COLLAUDO

DICHIARAZIONE DI CORRETTO MONTAGGIO: la sottoscritta Ditta dichiara di aver montato in maniera corretta ed in conformità alle prescrizioni sia del costruttore del veicolo che del costruttore del dispositivo stesso il seguente dispositivo di attacco meccanico:

Tipo:
 Il dispositivo di attacco sopra indicato è stato installato su autoveicolo
 Modello:
 Targa:
 Data:

TIMBRO e FIRMA

Si dichiara inoltre di aver informato l'utente del veicolo sull'USO e MANUTENZIONE del dispositivo stesso.