

# Genuine Accessories



## Vehicle Model Stinger

Model Year 2018-  
 Part No. J5F05 AK000  
 Language English  
 Rev. Date 8/14/2017

## Accessory: Pedal Kit (A/T)

Difficulty: B

**Note:** Difficulty stated above reflects the minimum level of expertise required to install the accessory:  
 (A) Customer  
 (B) Dealer Technician  
 (C) Master Technician or Specialist

### Application Notes

**Only applicable to Automatic Transmission Equipped Vehicles.**

### Instructional Symbols / Definitions



Denotes warnings that may lead to serious physical injury or vehicle damage



Denotes quality processes to be checked prior to moving to the next step

Denotes personal protective equipment (PPEs) that may be required for a step. Examples of safety equipment icons noted below:



Denotes cautions to be taken to avoid physical injury or electronic component damage



Denotes specific tools that are necessary to complete a step



Glasses



Gloves



Denotes cautions to be taken to avoid vehicle and component damage

N  
O  
T  
E

Denotes important information to be reviewed during the step



Mask



Hearing Protection

### Basic Required Tools

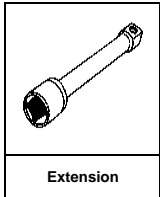
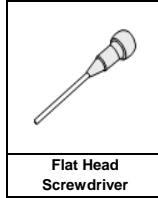
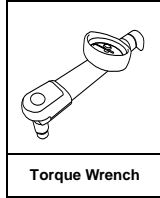
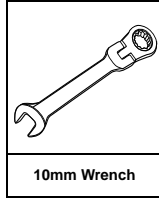
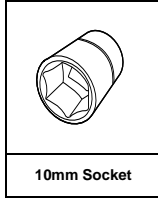
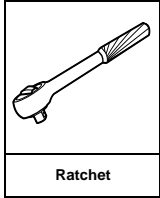

### Notes to the installer:

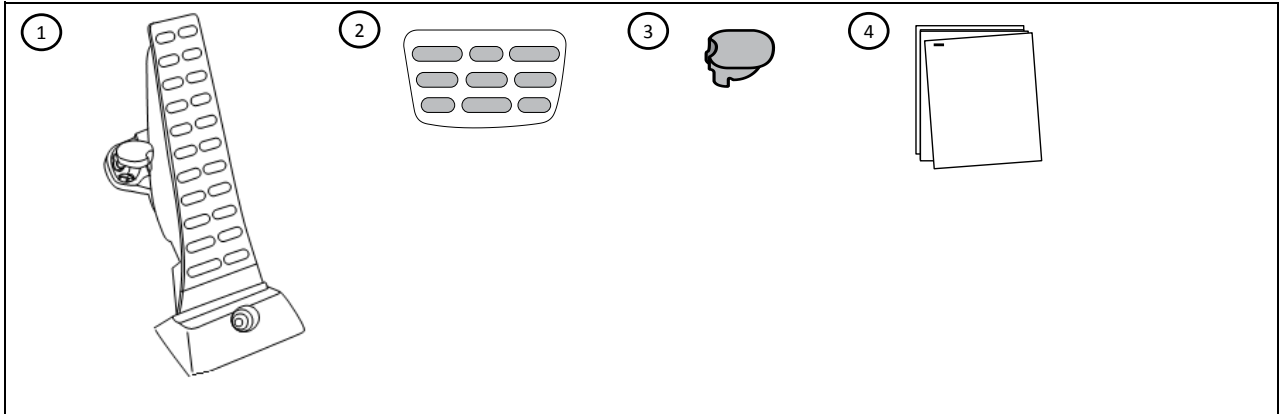

- 1 Read the entire Installation Instructions prior to beginning the installation of the part.
- 2 Make sure the vehicle is completely clean and dry in the area(s) the part is to be installed.
- 3 Ensure the vehicle is properly protected in the area(s) that the accessory is to be installed.
- 4 NEVER place tools on painted surfaces, seating surfaces, dash pad, console or floor carpet/mats.
- 5 Always wear appropriate personal protective equipment, including gloves, safety glasses, etc., when required.

### Kit Overview





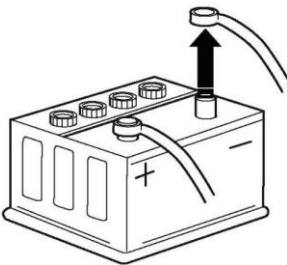

No.	Qty	Description
1	1	Pedal Assembly - Accelerator
2	1	Pad - Brake Pedal
3	1	Bolt Cap
4	1	Installation Instructions

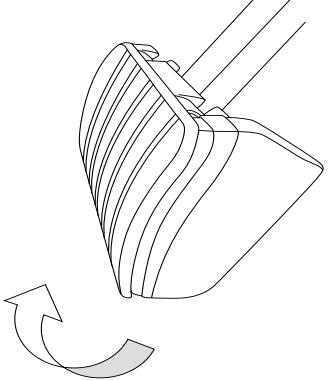
## Genuine Accessories

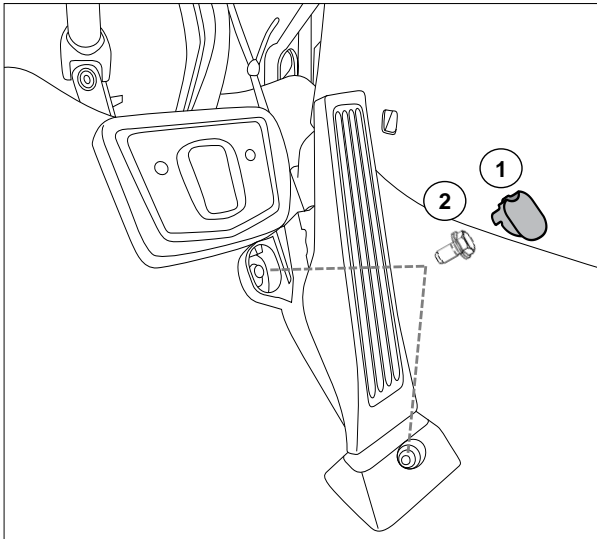

1		<b>10mm Wrench</b>
		
N O T E	<ol style="list-style-type: none"> <li>1. Remove floor trunk mat.</li> <li>2. Remove underfloor tray.</li> <li>3. Disconnect and isolate the negative battery cable from the battery.</li> </ol>	
<div style="display: flex; align-items: center;">  <p style="margin: 0; font-size: small;">WARNING! Shock Hazard. Do not touch vehicle's negative battery terminal to vehicle's positive battery terminal. Serious injury and damage to the vehicle may occur.</p> </div>		

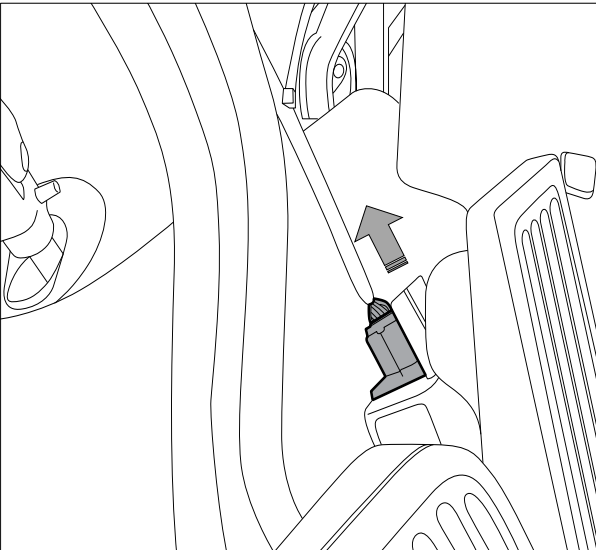

2		
		
N O T E	<ol style="list-style-type: none"> <li>1. Temporarily remove the left front floor mat from the vehicle.</li> <li>2. Detach the rubber pad from the brake pedal by pulling the right and left edges of the rubber pad away from the brake pedal as shown.</li> <li>3. Discard the rubber pad.</li> </ol>	

3		<b>Flat Head Screwdriver, Ratchet, Extension and 10mm Socket</b>
		
N O T E	<ol style="list-style-type: none"> <li>1. Remove the upper and lower bolt caps from the accelerator pedal using a flat head screwdriver.</li> <li>2. Discard the upper bolt cap and retain the lower bolt cap for reinstallation.</li> <li>3. Remove the two (2) bolts from the accelerator pedal.</li> <li>4. Save the two (2) bolts for reinstallation.</li> </ol>	

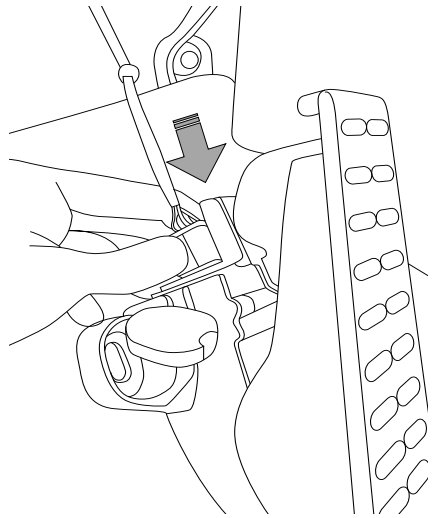

4		
		
N O T E	<ol style="list-style-type: none"> <li>1. Disconnect the electrical connector from the accelerator pedal by pressing the side release tab and then pulling the connector up and away from the accelerator pedal.</li> <li>2. Discard the accelerator pedal.</li> </ol>	
<div style="display: flex; align-items: center;">  <p style="margin: 0; font-size: small;">Be careful not to pull on the wire harness when disconnecting the electrical connector to avoid damage.</p> </div>		

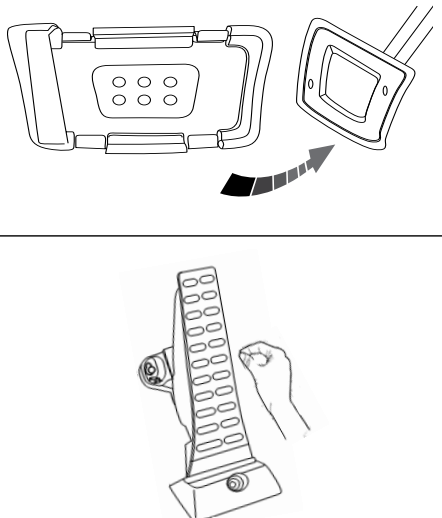
## Genuine Accessories

5		
		
NOTE	<ol style="list-style-type: none"> <li>1. Connect the electrical connector to the provided Accessory Accelerator Pedal.</li> </ol>	
	<p>Make sure the electrical connector makes an audible 'click' noise to confirm that it is fully connected to the Accessory Accelerator Pedal.</p>	

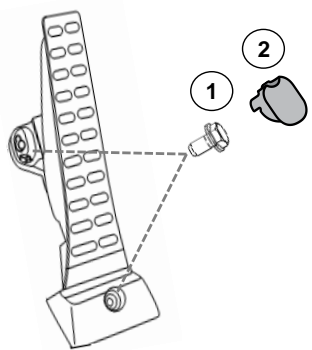

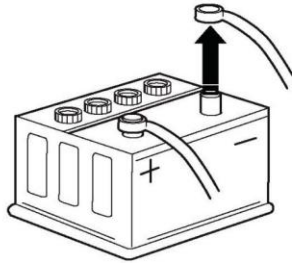

7		
		
NOTE	<ol style="list-style-type: none"> <li>1. Install the provided Accessory Brake Pedal Pad onto the brake pedal by engaging the side cover and then the lower hook onto the lower part of the brake pedal as shown.</li> <li>2. By hand, apply pressure to the upper part of the Accessory Brake Pedal Pad until an audible 'click' is heard.</li> <li>3. Remove the protective film from the Accessory Brake Pedal Pad and Accessory Accelerator Pedal.</li> <li>4. Reinstall the floormat. Ensure that floormat anchors are installed correctly.</li> </ol>	
	<p>Ensure that floormat anchors are installed correctly.</p>	

6		Ratchet, Extension, 10mm Socket and Torque Wrench
		
<p>Torque: 9.8~14.7 N.m (1.0~1.5 Kgf.m, 7.2~10.8 lb-ft)</p>		
NOTE	<ol style="list-style-type: none"> <li>1. Reinstall the accelerator pedal bolts removed in step 3.</li> <li>2. Torque the bolts to 9.8~14.7 N.m (1.0~1.5 Kgf.m, 7.2~10.8 lb-ft).</li> <li>3. Install the provided upper bolt cap and then the lower bolt cap removed in step 3.</li> </ol>	

8		10mm Wrench, Ratchet, 10mm Socket, and Torque Wrench
		
NOTE	<ol style="list-style-type: none"> <li>1. Reconnect the negative battery cable, and torque to: 3.93 N.m (0.40 Kgf.m, <b>34.8 lb-in</b>).</li> <li>2. Reinstall the under floor tray and floor trunk mat.</li> <li>3. Perform the function check on the following page.</li> </ol>	
	<p><b>WARNING!</b> Shock Hazard. Do not touch vehicle's negative battery terminal to vehicle's positive battery terminal. Serious injury and damage to the vehicle may occur.</p>	

## Genuine Accessories

**Function Check**

Item to be Checked		Result	
	Verify the Accessory Accelerator Pedal Bolts are torqued to: 9.8~14.7 N.m (1.0~1.5 Kgf.m, 7.2~10.8 lb-ft). Make sure the electrical connector is fully seated and connected to the Accessory Accelerator Pedal.	The Accessory Accelerator Pedal is properly installed.	
	Verify the Accessory Brake Pedal Pad is fully installed and not loose.	The Accessory Brake Pedal Pad is properly installed.	
	Make sure the floor mat is installed and does not interfere with the Accessory Accelerator Pedal or Accessory Brake Pedal.	The floor mat is properly installed.	
	Check that the accelerator pedal functions as intended. Start vehicle, keep gear selector in park, and apply gentle pressure to the accelerator pedal. Do <u>NOT</u> test drive vehicle.	Accessory Accelerator Pedal does not bind and operates smoothly.	