

Genuine Accessories



Vehicle Model Niro

Model Year 2017-
Part No. G5F05 AK000

Language English
Rev. Date 08.12.2016

Accessory: Pedal Kit (AT)

Difficulty: B

Note: Difficulty stated above reflects the minimum level of expertise required to install the accessory:
(A) Customer
(B) Dealer Technician
(C) Master Technician or Specialist

Instructional Symbols / Definitions

	Denotes warnings that may lead to serious physical injury or vehicle damage		Denotes quality processes to be checked prior to moving to the next step	Denotes personal protective equipment (PPEs) that may be required for a step. Examples of safety equipment icons noted below:	
	Denotes cautions to be taken to avoid physical injury or electronic component damage		Denotes specific tools that are necessary to complete a step		
	Denotes cautions to be taken to avoid vehicle and component damage	N O T E	Denotes important information to be reviewed during the step		

Basic Required Tools

Ratchet	Nylon Panel Removal Tool	12mm Deepwell Socket	Torque Wrench	Extension

Notes to the installer:



- 1 Read the entire Installation Instructions prior to beginning the installation of the part.
- 2 Make sure the vehicle is completely clean and dry in the area(s) the part is to be installed.
- 3 Ensure the vehicle is properly protected in the area(s) that the accessory is to be installed.
- 4 NEVER place tools on painted surfaces, seating surfaces, dash pad, console or floor carpet/mats.
- 5 Always wear appropriate personal protective equipment, including gloves, safety glasses, etc., when required.
- 6 Make sure the accessory brake pedal pad is fully locked onto the brake pedal and is **not** loose.
- 7 Make sure to disconnect the 12V circuit at the ground connector located behind the ground disconnect access cover in the driver side rear cargo area trim panel.

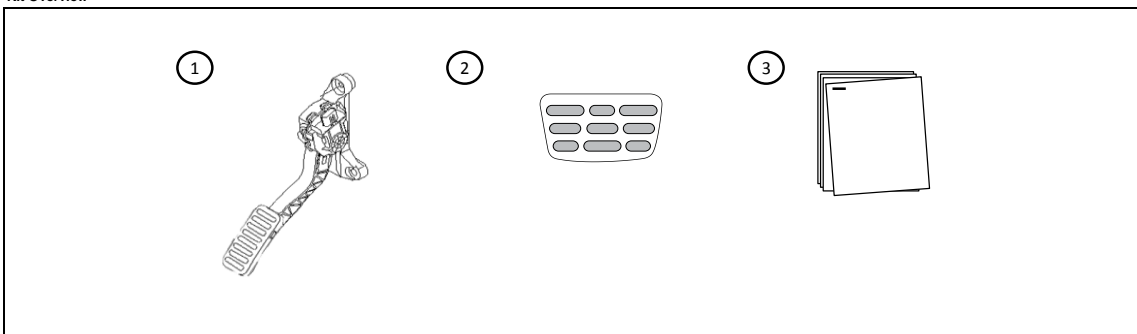

Kit Overview



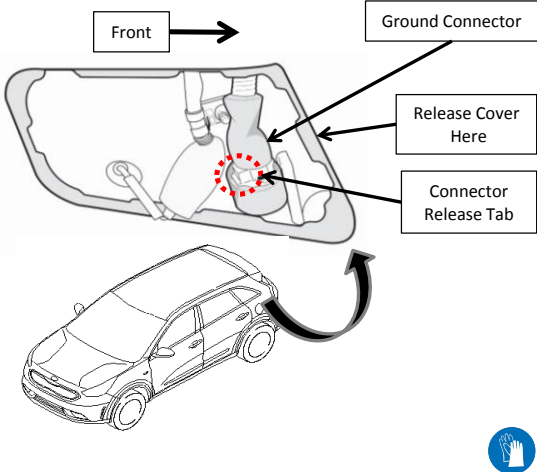

No.	Qty	Description
1	1	Accelerator Pedal Assembly
2	1	Brake Pedal Pad
3	1	Installation Instructions

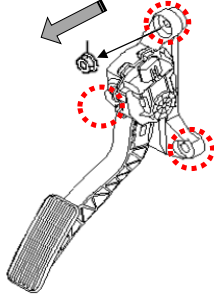
Genuine Accessories

1		Nylon Panel Removal Tool
		
NOTE	<p>Disconnect the negative battery cable as follows:</p> <ol style="list-style-type: none"> 1. Fold down the driver side rear seat back to expose the ground disconnect access cover located on the driver side cargo area side trim panel. 2. Using a nylon panel removal tool, gently release the ground disconnect access cover at the front of the cover and remove from the side trim panel. 3. Locate the large ground connector. Press in the release tab on the rear facing side of the connector and pull up about 1-inch to release the connector. The ground circuit is now disconnected. 	
	<p>WARNING! Shock Hazard. Do not touch any visible electrical terminals. Serious injury and damage to the vehicle may occur.</p>	

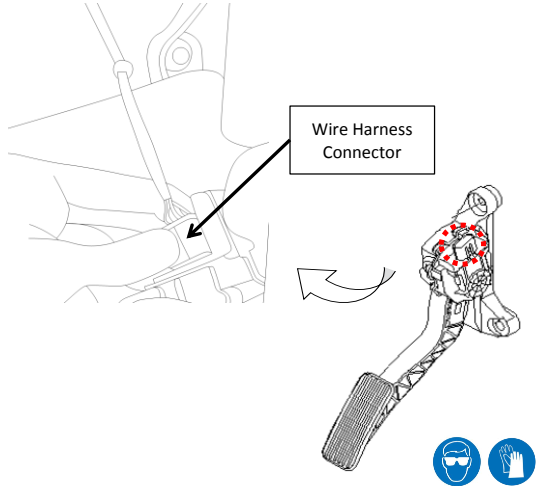
2		12mm Deepwell Socket, Extension, and Ratchet
		
NOTE	<ol style="list-style-type: none"> 1. Temporarily remove the floor mat for better accessibility. 2. Remove the three (3) M8 nuts from the OEM accelerator pedal assembly using a 12mm deepwell socket. 3. Save the nuts for re-installation. 	
	<p>Be careful not to drop the nuts under the factory carpet.</p>	

3		Wire Harness Connector
		
NOTE	<ol style="list-style-type: none"> 1. Disconnect the wire harness connector from the OEM accelerator pedal by pressing the side release tab, and pulling up and away from accelerator pedal as indicated by the arrow. 2. Carefully remove the OEM accelerator pedal assembly from the vehicle. 	
	<p>Be careful not to damage the wire harness or connector when removing.</p>	

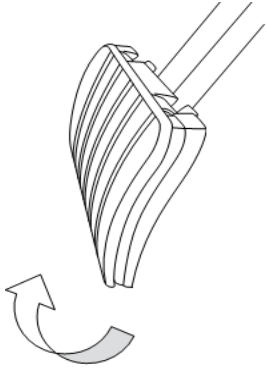
4		OEM rubber brake pedal pad
		
NOTE	<ol style="list-style-type: none"> 1. Detach the OEM rubber brake pedal pad from the brake pedal and discard. 	

Genuine Accessories

5  12mm Deepwell Socket, Extension, Ratchet, and Torque Wrench

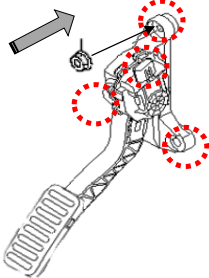



Torque: 12.8 ~ 15.7 N.m (1.3 ~ 1.6 Kgf.m, 9.4 ~ 11.6 lb-ft)





NOTE

1. Install the accessory accelerator pedal onto the three (3) M8 studs on the bulkhead.
2. Install the three (3) M8 nuts removed in step 2.
3. Torque the nuts to 12.8 ~ 15.7 N.m (1.3 ~ 1.6 Kgf.m, 9.4 ~ 11.6 lb-ft).
4. Reinstall the connector into the accessory accelerator pedal making sure it locks into place.

 Make sure the connector is fully locked into the accessory accelerator pedal socket.

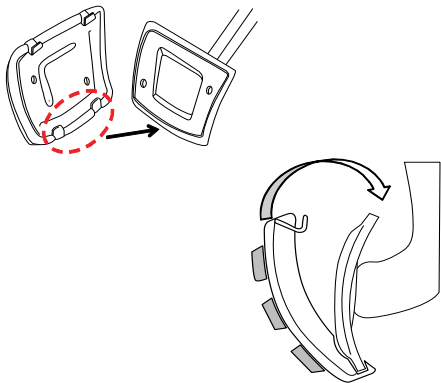
6 









NOTE

1. Engage lower hooks of accessory brake pad onto the lower part of the brake pedal.
2. Rotate pad upwards and apply pressure to the upper part of the accessory brake pad until an audible 'click' is heard.
3. Remove any protective film.
4. Reconnect the large ground connector by pushing down until it locks into place with a "click".
5. Replace the ground disconnect access cover and fold the rear seat back up.

Note: Make sure that the ground connector is locked by gently pulling upwards.

 Make sure accessory brake pedal pad is fully locked onto the brake pedal and is **not** loose.
Make sure the ground connector is **locked**.

Visual Check	
	Item to be Checked
	Make sure the ground connector is locked, the ground disconnect access cover is properly installed, and the rear seat back is folded up.
	Test drive vehicle to verify function of accessory accelerator pedal.
	Make sure all three (3) M8 nuts are torqued.
	Make sure the wire harness connector is fully locked into the accessory accelerator pedal socket.
	Make sure accessory brake pedal pad is fully locked onto the brake pedal and is not loose.

Result	
Ground connector is locked and access cover installed. Seat folded up.	
Accessory accelerator pedal does not bind and operates smoothly.	
Three (3) M8 nuts are torqued.	
Electrical connector locked into accessory accelerator pedal socket.	
Accessory brake pedal pad is fully locked onto the brake pedal and is not loose.	