

## KIA Genuine Accessories













Vehicle Model	Soul	Accessory	Sports Pedal (A/T)
Model Year	2014~	Difficulty	(B)
Part No.	B2F05 AB000		

- Accessory Installation



**Note:** Difficulty stated above reflects the minimum level of expertise required to install the accessory.

( A ) Customer    ( B ) Dealer Technician    ( C ) Master Technician

### Instructional Symbols / Definitions

 Denotes warnings that may lead to serious physical injury or vehicle damage.	 Denotes quality processes to be checked prior to moving to the next step.	Denotes safety equipment required to be used such as a mask, safety glasses, gloves, and hearing protection.
 Denotes cautions to be taken to avoid physical injury or electronic component damage.	 Denotes specific tools that are necessary to complete the step.	 Mask
 Denotes cautions to be taken to avoid vehicle and component damage.	 Denotes instructional steps necessary to complete the process.	 Safety Glasses
		 Gloves
		 Hearing Protection

### Basic Required Hand Tools

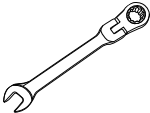
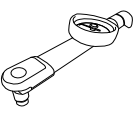
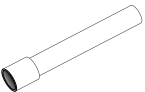
 Flat Head Screwdriver	 Ratchet	 10mm Socket	 10mm Wrench
 Torque Wrench	 Extension		

### Notes to the Installer:

- 1) Read the entire installation instructions prior to beginning the installation of this accessory.
- 2) Make sure the vehicle is completely clean before the accessory is installed.
- 3) Ensure the vehicle is properly protected in the area(s) that the accessory is to be installed.
- 4) To prevent vehicle damage, never place tools on top of painted surfaces, seats, dash pad, console or floor carpet/mats.
- 5) Always wear appropriate safety gear to include gloves and safety glasses when required.

# KIA Genuine Accessories

## Kit Overview

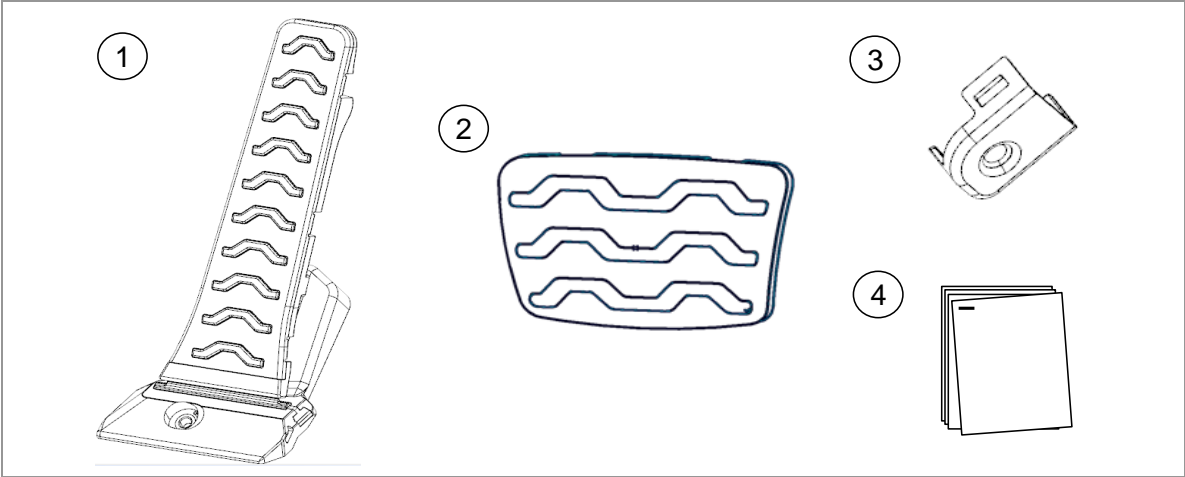

No.	Qty.	Description
1	1	Accelerator Pedal
2	1	Brake Pad
3	1	Retaining Cap
4	1	Installation Instructions

KIA Genuine Accessories

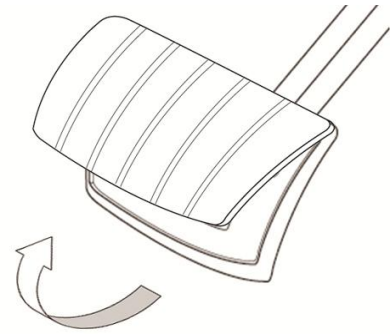
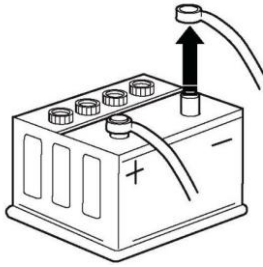

	10mm Wrench	1
NOTE	1. Disconnect and isolate vehicle's negative battery cable.	
	<b>WARNING! Shock Hazard. Do not touch vehicle's negative battery terminal to vehicle's positive battery terminal. Serious injury and damage to the vehicle may occur.</b>	

		2
NOTE	1. If necessary, temporarily remove the floor mat from the vehicle for better accessibility. 2. Detach the OEM rubber pad from the brake pedal by pulling the pad from the bottom of the pedal and up, as shown by the arrow above.	

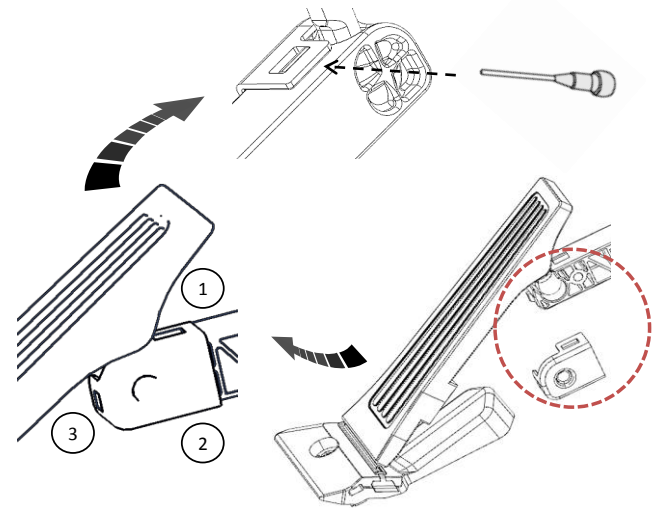
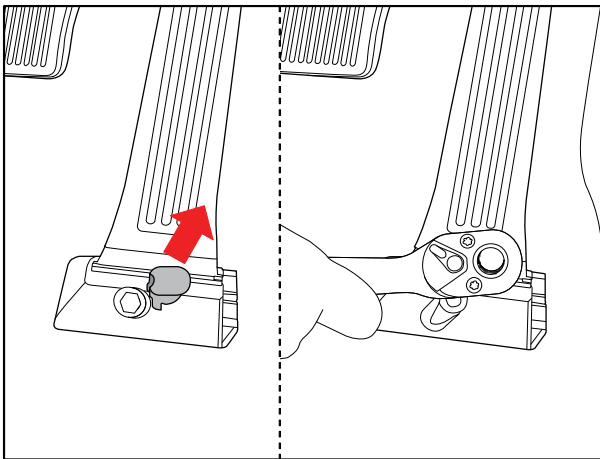

	Flat Head Screwdriver, Extension, Ratchet and 10mm Socket	3
NOTE	1. Carefully remove the bolt cap from the accelerator pedal using a flat head screwdriver. 2. Save the bolt cap for reinstallation. 3. Remove the bolt from the OEM accelerator pedal using a 10mm socket. 4. Save the bolt for reinstallation. 5. Carefully pull out the bottom of the OEM accelerator pedal from the floor panel.	

	Flat Head Screwdriver	4
NOTE	1. Using a flat head screwdriver, carefully disengage three (3) retention tabs from the retaining cap of the accelerator pedal, following the sequence above. 2. Discard the retaining cap. 3. Remove the OEM accelerator pedal by rotating the accelerator pedal to the right and then sliding the pivot ball out of the accelerator module arm.	

KIA Genuine Accessories

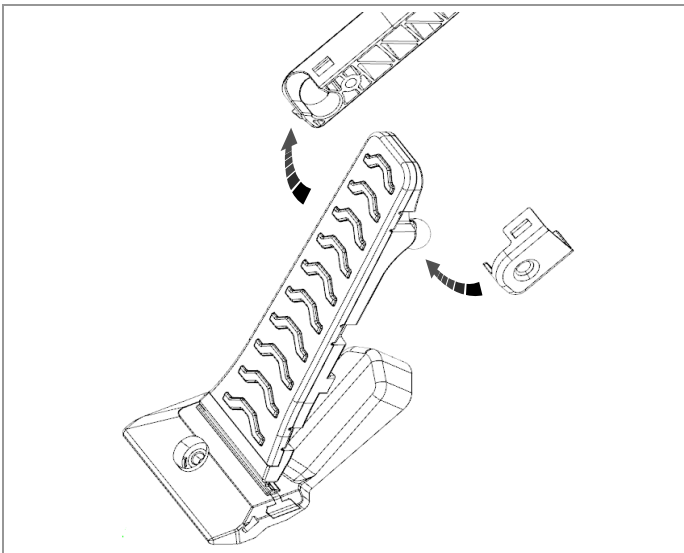

 5

- NOTE**
1. Install the accessory accelerator pedal by sliding the pivot ball into the side of the accelerator module arm and then rotating the accelerator pedal to the left.
  2. Install the provided retaining cap onto the accelerator module arm, ensuring all three (3) retention tabs are fully engaged.

 **Make sure the three (3) retention tabs are fully locked into the accelerator module arm.**

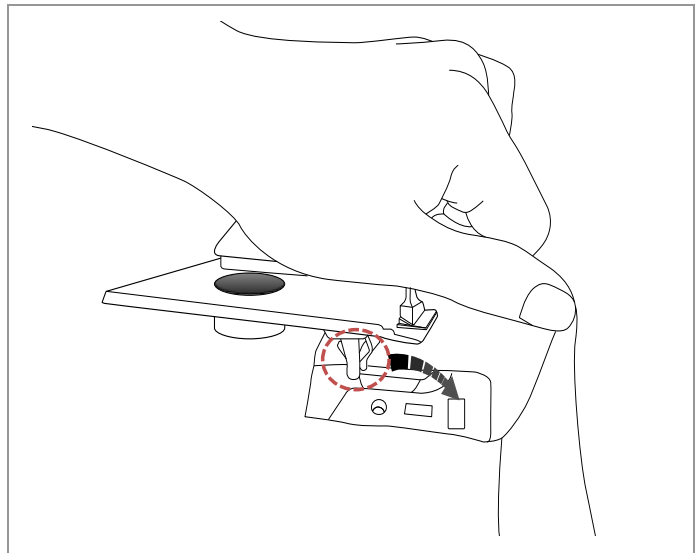



 6

- NOTE**
1. Insert the bottom of the accessory accelerator pedal into the floor panel, ensuring the retention clip is fully inserted.

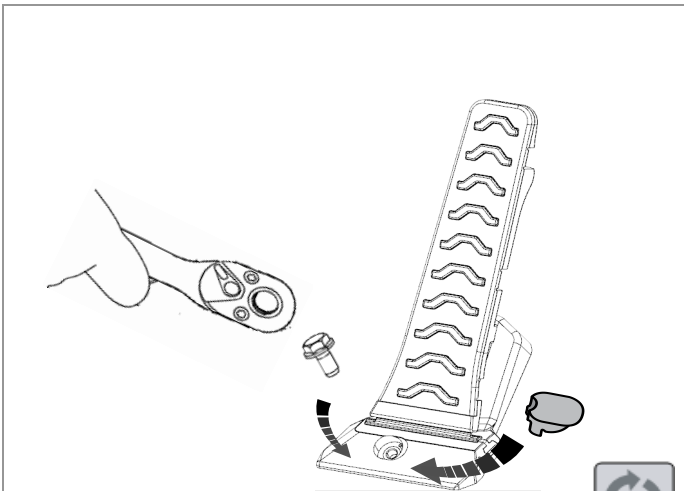
 **Make sure the retention clip is fully installed.**



Torque: 11.3 N.m (1.15 Kgf.m, 100 in-lbs) 

 Ratchet, 10mm Socket, Extension, and Torque Wrench 7

- NOTE**
1. Reinstall the accelerator pedal bolt to the floor using a 10mm socket.
  2. Torque the bolt to 11.3 N.m (1.15 Kgf.m, 100 in-lbs).
  3. Reinstall the accelerator pedal bolt cap as shown.

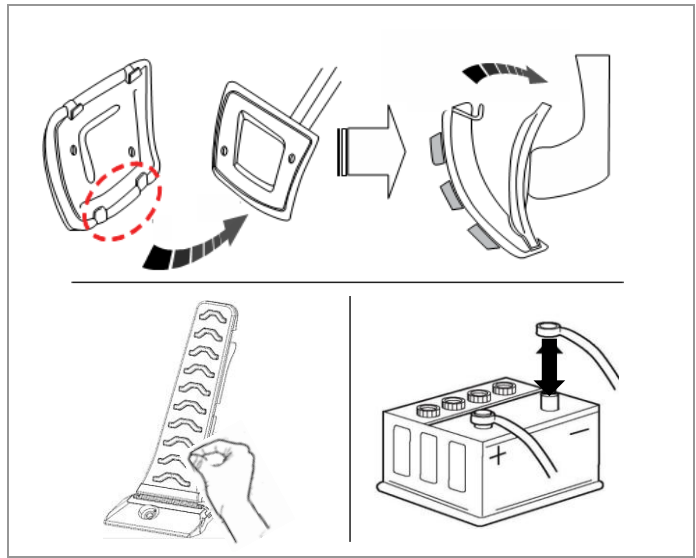





 10mm Wrench 8

- NOTE**
1. Engage the lower hook of the accessory brake pedal pad onto the lower part of the brake pedal as shown.
  2. Apply pressure to the upper part of the accessory brake pedal pad until an audible 'click' is heard.
  3. Peel the protective film off of each accessory pad.
  4. Reconnect the negative lead to the battery with a 10mm wrench.
  5. Installation is complete.

 **Test drive vehicle to verify function of the accessory accelerator pedal.**

## KIA Genuine Accessories Function Check

Items To Be Checked	Results Of The Check	
	Do not leave the 10mm wrench in the engine compartment or on the battery after removing the negative battery cable.	10mm wrench is not in engine compartment or on battery.
	Make sure the three (3) retention tabs of the retaining cap are fully engaged onto the accelerator module arm.	Retaining cap is fully engaged onto accelerator module arm.
	Accessory accelerator pedal retention clip is fully inserted into vehicle floor.	Retention clip is fully installed.
	Test drive vehicle to verify function of accessory accelerator pedal.	Accessory accelerator pedal does not bind and operates smoothly.