

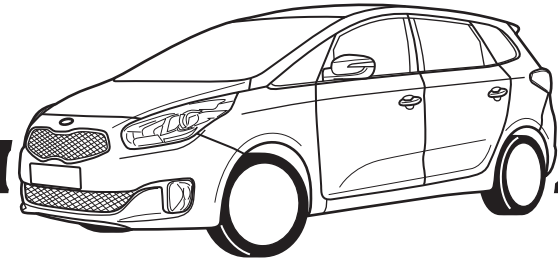

INSTALLATION INSTRUCTIONS

90 Min.

Kia RP



Part no.: A4621ADE00CP

DE Einbauanleitung Elektrosatz Anhängervorrichtung mit 13-P Steckdose lt. DIN/ISO Norm 11446	DK Monteringsvejledninger for det elektriske ledningsføringssæt for trækstang med 13-N stikdåse, DIN/ISO, norm 11446.
FR Instructions de montage du faisceau électrique pour crochet d'attelage conforme à la norme DIN/ISO 11446 prise 13-V.	FI Ohjeet vetokoukun sähkökaapelisarjan asentamiseen, jossa on DIN/ISO 11446 mukainen 13-N liitin.
NL Montage-handleiding elektrokabelset voor trekhaak met 13-P contactdoos vlg. DIN/ISO norm 11446.	GR Οδηγίες συναρμολόγησης ηλεκτρικού σετ καλωδίων μπάρας ρυμούλκησης με υποδοχή 13-P μέχρι DIN/ISO Κανόνας 11446.
GB Fitting instructions electric wiring kit tow bar with 13-P socket up to DIN/ISO Norm 11446.	NO Monteringsanviser elkabelsett for trekkrok med 13-P koblingsboks ifølge DIN/ISO norm 11446.
ES Instrucciones de montaje de kit eléctrico para enganche de remolque con caja de conexiones 13-P según norma DIN/ISO 11446.	PL Instrukcje montażu zestawu okablowania elektrycznego dyszla holowniczego z 13-stykowym gniazdem DIN/ISO 11446.
IT Istruzioni di montaggio di set di cavi elettrici per gancio da traino con zoccolo a 13-P conforme alla norma DIN/ISO 11446.	RU Инструкция по монтажу комплекта электрического кабеля для сцепного крюка и 13-полюсной розетки согласно стандарту DIN/ISO 11446.
SE Monteringsanvisningar elkabelsats för dragkrok med 13-P kontaktdosa enligt DIN/ISO norm 11446.	SK Montážne pokyny pre ochranu proti podideniu
CZ Montážní pokyny: souprava pro elektrické propojení tažné tyče s 13-P zásuvkou do normy DIN/ISO 11446.	

PRE-INSTALLATION CAUTIONS/NOTES:

DE - Wir weisen ausdrücklich darauf hin, dass eine unsachgemäße und nicht in einer Fachwerkstatt durchgeführte Montage einen Verzicht auf Entschädigung jeglicher Art insbesondere bezüglich des Produkthaftpflichtrechts zur Folge hat	- Technische Änderungen vorbehalten.
FR - Il est expressément prévu qu' on ne saurait se prévaloir d'un quelconque préjudice contractuel ou rédhitoire si le montage avait été fait en dépit des dites instructions ou dans un garage ne disposant pas des équipements adéquats.	- Sous réserve de modifications techniques.
NL - Wij wijzen er met nadruk op, dat ondeskundige en niet door een vakkundige werkplaats uitgevoerde montage tot gevolg heeft dat daardoor ieder recht op schadevergoeding, ook op wettelijke aansprakelijkheid inzake producten, vervalt.	- Technische wijzigingen voorbehouden.
GB - We would expressly point out that assembly not carried out properly by a competent installer will result in cancellation of any right to damage compensation, in particular those arising by virtue of the product liability act.	- Contents of these kits and their fitting manuals are subject to alteration without notice, please ensure that these instructions are read and fully understood before commencing installation.
ES - El montaje inapropiado y efectuado por personal no cualificado originará la pérdida de todo derecho a indemnización o la expiración de toda responsabilidad civil con respecto al producto.	- Nos reservamos el derecho a efectuar modificaciones técnicas.
IT - Sottolineiamo espressamente che un montaggio inadeguato ed eseguito da un'officina non specializzata ha come conseguenza il decadere di qualsiasi diritto al risarcimento danni, nonché alla responsabilità legale relativa ai prodotti.	- Ci si riserva il diritto di apportare modifiche tecniche.
SE - Vi påpekar med eftertryck att all rätt till skadeersättning och all laglig ansvarighet förfaller om monteringen inte har utförts på rätt sätt och av en professionell verkstad.	- Tekniska ändringar förbehålles.
CZ - Výslovně zdůrazňujeme, že jakákoli montáž, která není provedená ve specializované dílně, má za následek odvolání nároků na kompenzaci jakéhokoli druhu, obzvláště vyplývajících ze zákona o odpovědnosti za způsobené škody.	- Změny mohou být provedeny bez oznámení.
DK - Vi ønsker at gøre udtrykkeligt opmærksom på at forkert samling, der ikke er udført af et specialiseret værksted, resulterer i bortfaldelse af kompenseringskrav af alle slags, i særdeles krav der måtte opstå omkring det lovpligtige ansvar.	- Kan ændres uden varsel.
FI - Korostamme, että kaikki oikeudet vahinkokorvaukseen kuten myös valmistajan laillinen vastuu raukeavat, mikäli asennusta ei ole toteutettu oikealla tavalla eikä ammattitaitoisen asiantuntijan toimesta.	- Oikeus tekniisiin muutoksiin ilman erillistä huomautusta pidätetään.
GR - Επισημαίνουμε κατηγορηματικά ότι οποιαδήποτε εσφαλμένη συναρμολόγηση, η οποία δεν έχει πραγματοποιηθεί ειδικό εργαστήριο θα οδηγήσει σε αποποίηση των αξιώσεων επιβολής αποζημιώσεων οποιοδήποτε είδους, ειδικά όσα προκύπτουν από το νόμο ευθύνης προϊόντων.	- Μπορεί να τροποποιηθεί χωρίς προηγούμενη ειδοποίηση.
NO - Vi påpeker ettertrykkelig at all rett til skadeerstatning og rettslig ansvar forfaller dersom monteringen ikke er blitt utført på riktig måte og av et profesjonelt verksted.	- Tekniske endringer forbeholdes.
PL - Chcielibyśmy wyraźnie zaznaczyć, iż wszelki nieprawidłowy montaż, który nie jest wykonywany w specjalistycznym warsztacie pociąga za sobą utratę możliwości dochodzenia wszelkiego typu roszczeń, w szczególności tych wynikających z odpowiedzialności producenta za swój produkt.	- Podlega zmianom bez powiadomienia.
RU - Мы убедительно предупреждаем, что монтаж произведенный не компетентным лицом и в не соответствующих или предназначенных для монтажа мест, освобождает нас от возмещения какого-либо ущерба и снимает с нас ответственность за продукт.	- Не исключены изменения в инструкции. Убедительная просьба перед монтажом прочитать и понять полностью всю инструкцию.
SK - Výslovné upozorňujeme, že inštalácia, ktorá sa vykoná nesprávne alebo nekompetentnou osobou, spôsobí zrušenie akýchkoľvek práv na kompenzáciu škôd, a to obzvlášť tých, ktoré vyplývajú zo zákona o zodpovednosti za chybný výrobok.	- Obsah týchto súprav a ich montážne príručky podliehajú zmenám bez predchádzajúceho upozornenia. Uistite sa, že si tieto pokyny pred vykonaním inštalácie prečítate a plne im porozumiete.

INSTALLATION INSTRUCTIONS - A4621ADE00CP

- Einzelteilliste (DE) Liste de pièces (FR) Onderdelenlijst (NL) Part list (GB) Lista de componentes (ES) Elenco componenti (IT) Dellista (SE) Seznam dílů (CZ) Del-liste (DK) Osaluettelo (FI) Κατάλογος εξαρτημάτων (GR) Delliste (NO) Lista części (PL) Справочник составных частей (RU) Zoznam dielov (SK)

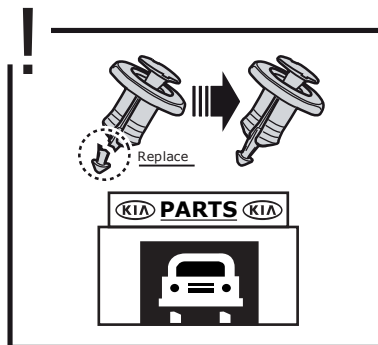
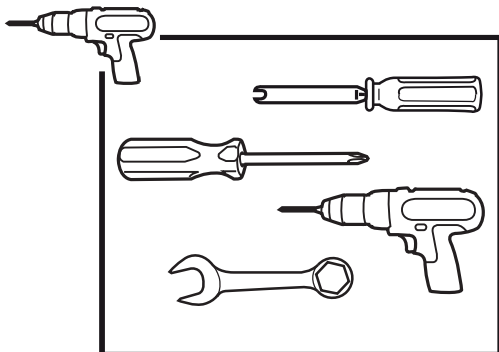
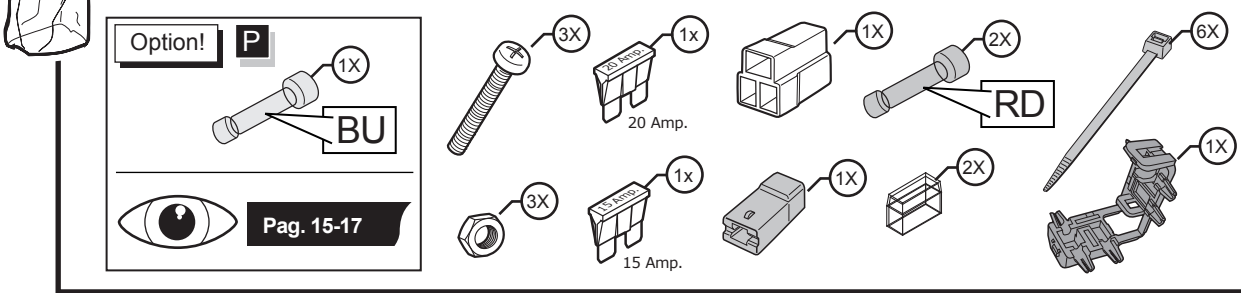
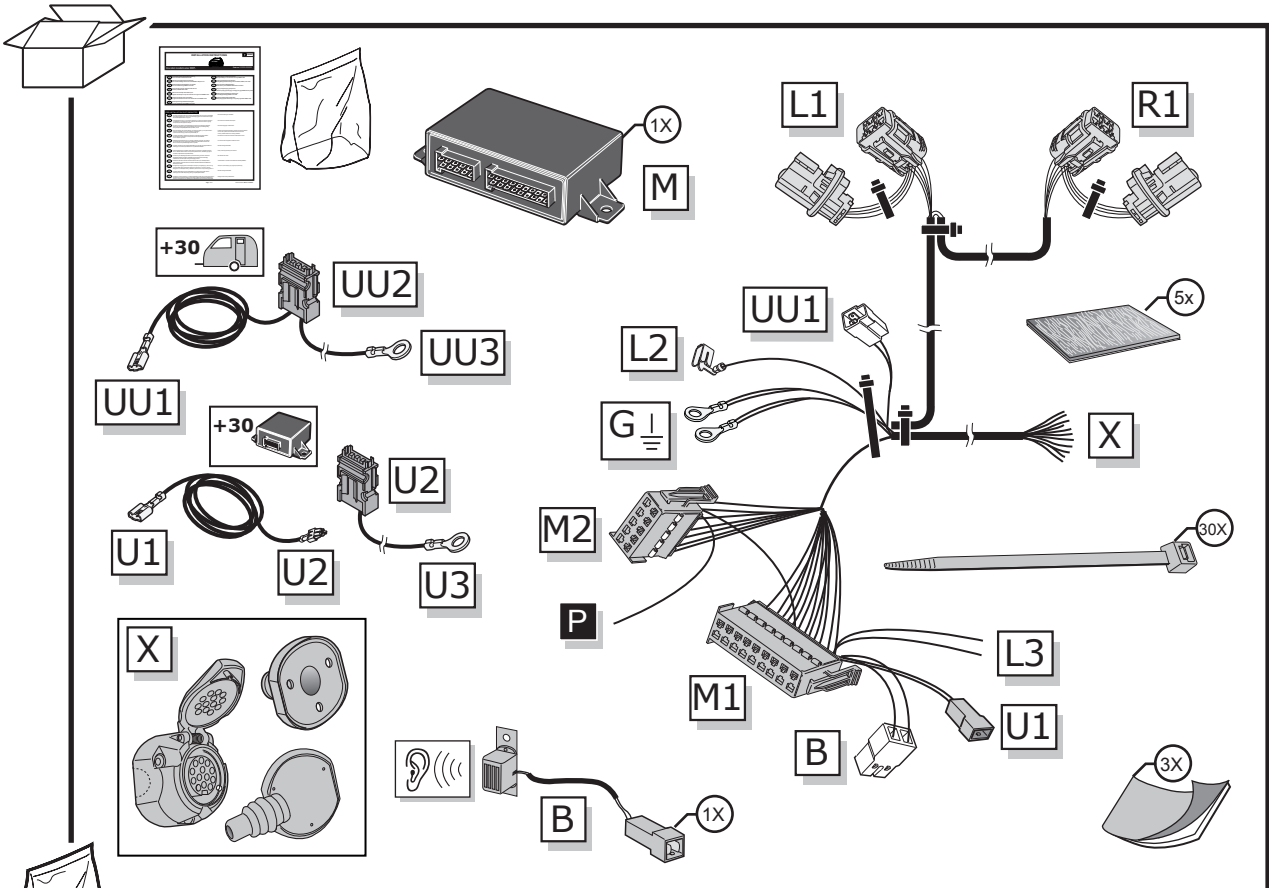

INSTALLATION INSTRUCTIONS - A4621ADE00CP

	BK	BN	BU	GY	GN	WH	YE	OG	PE	PI	RD
DE	Schwarz	Braun	Blau	Grau	Grün	Weiß	Gelb	Orange	Violett	Rosa	Rot
FR	Noir	Marron	Blue	Gris	Vert	Blanc	Jaune	Orange	Violet	Rose	Rouge
NL	Zwart	Bruin	Blauw	Grijs	Groen	Wit	Geel	Oranje	Paars	Roze	Rood
GB	Black	Brown	Blue	Grey	Green	White	Yellow	Orange	Purple	Pink	Red
ES	Negro	Marrón	Azul	Gris	Verde	Blanco	Amarillo	Naranja	Morado	Rosa	Rojo
IT	Nero	Marrone	Blu	Grigio	Verde	Bianco	Giallo	Arancione	Viola	Rosa	Rosso
SE	Svart	Brun	Blå	Grå	Grön	Vit	Gul	Orange	Lila	Rosa	Röd
CZ	Černá	Hnědá	Modrá	Šedá	Zelená	Bílá	Žlutá	Oranžová	Fialová	Růžová	Červená
DK	Sort	Brun	Blå	Grå	Grøn	Hvid	Gul	Orange	Lilla	Pink	Rød
FI	Musta	Ruskea	Sininen	Harmaa	Vihreä	Valkoinen	Keltainen	Oranssi	Purppura	Vaaleanpunainen	Punainen
GR	Μαύρο	Καφέ	Μπλε	Γκρι	Πράσινο	Λευκό	Κίτρινο	Πορτοκάλι	Μοβ	Ροζ	Κόκκινο
NO	Svart	Brun	Blå	Grå	Grønn	Hvit	Gul	Oransje	Lilla	Rosa	Rød
PL	Czarny	Brazowy	Niebieski	Szary	Zielony	Biały	Żółty	Pomarańczowy	Purpurowy	Różowy	Czerwony
RU	черный	Čierna	синий	серый	зеленый	белый	желтый	оранжевый	пурпурный	розовый	красный
SK	Čierna	Čierna	Modrá	Sivá	Zelená	Biela	Žltá	Oranžová	Fialová	Ružová	Červená

INFO

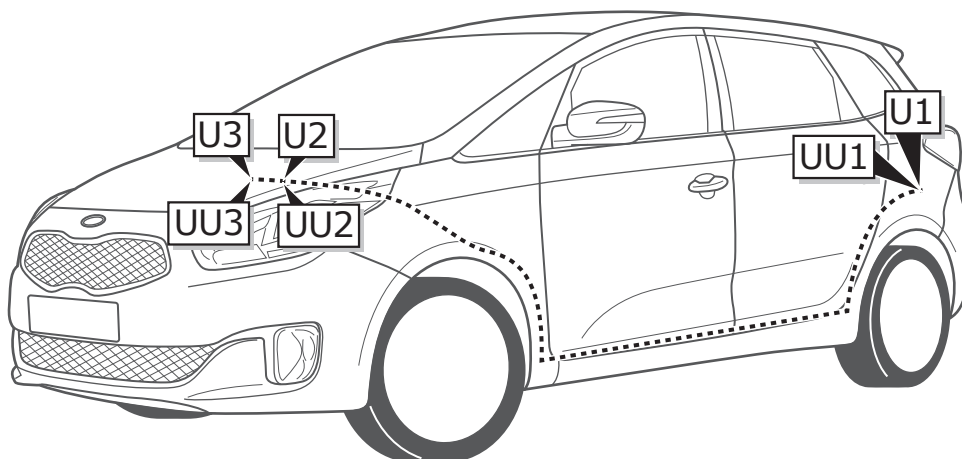
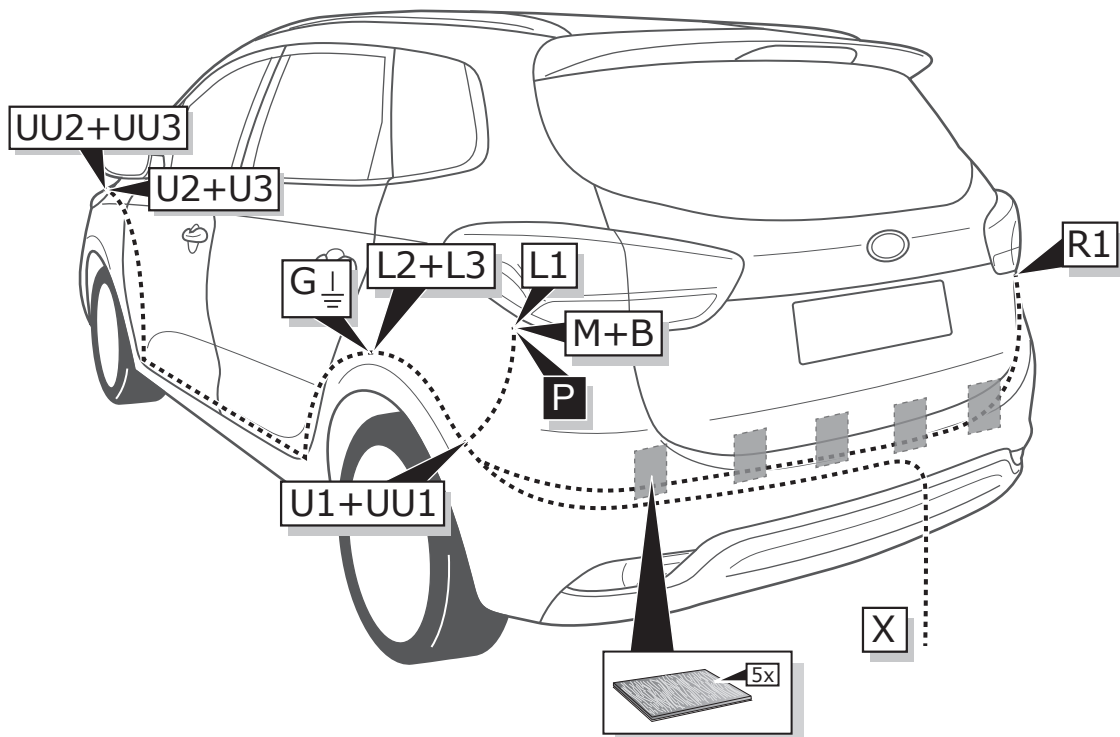

ROUTING

INSTALLATION INSTRUCTIONS - A4621ADE00CP

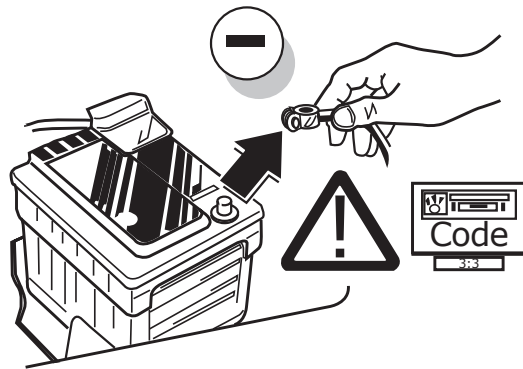

Fig 1

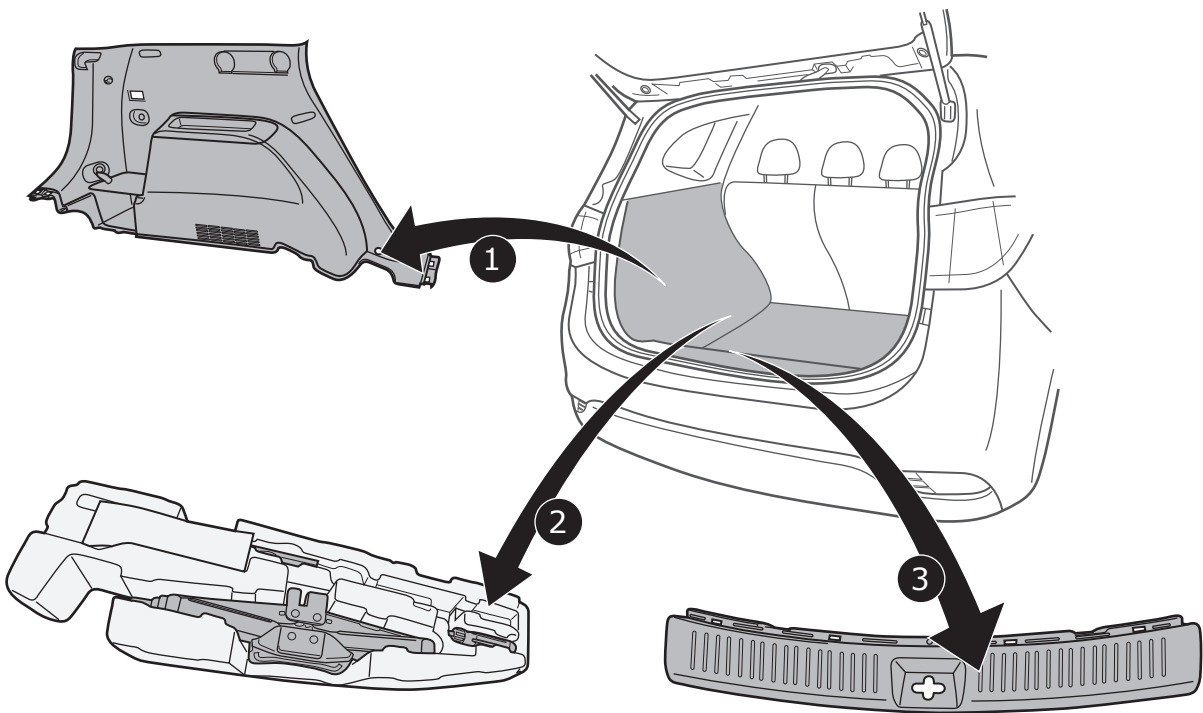

Fig 2

7 Seats

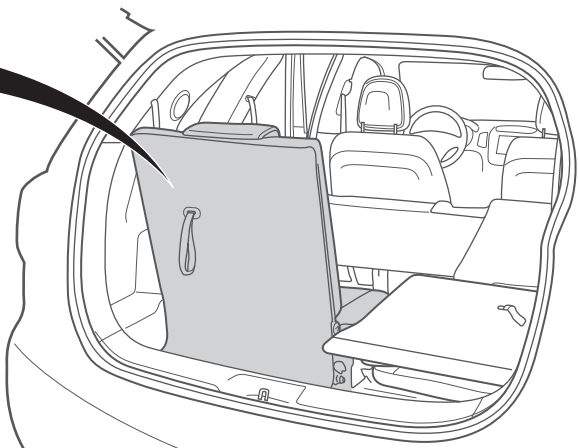
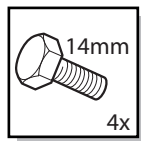
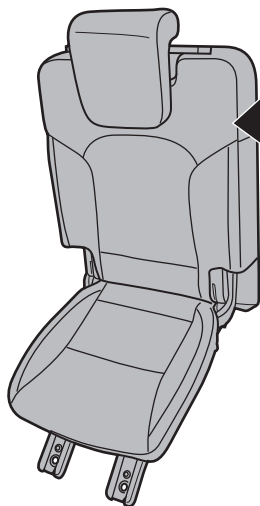
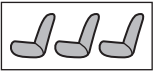

Fig 3

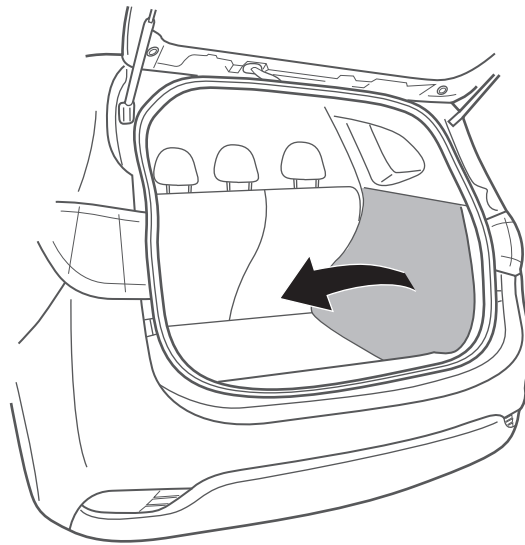
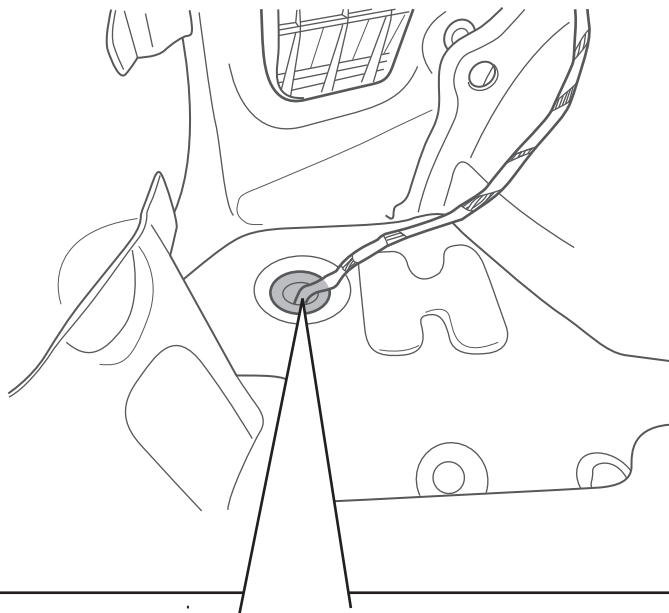
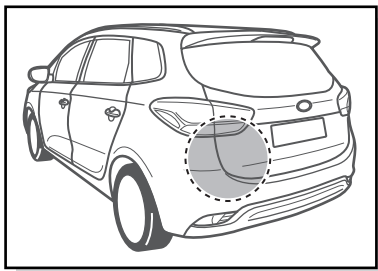
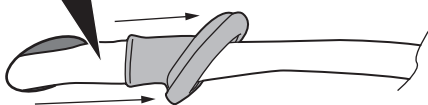

Fig 4



- | | |
|--------------------------------|-------------------------|
| DE Klebeband entfernen | DK Aftag tapen |
| FR Enlevez Ruban adhésif | FI Poista teippi |
| NL Tape verwijderen | GR Αφαιρέστε την ταινία |
| GB Remove tape | NO Fjern limbåndet |
| ES Retirar la cinta adhesiva | PL Zdjąć taśmę |
| IT Rimuovere il nastro adesivo | RU Удаление ленты |
| SE Avlägsna klisterbandet | SK Odstráňte pásku |
| CZ Odstraňte pásku | |



1

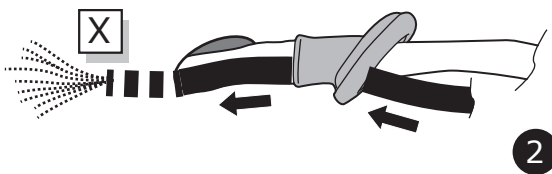

2

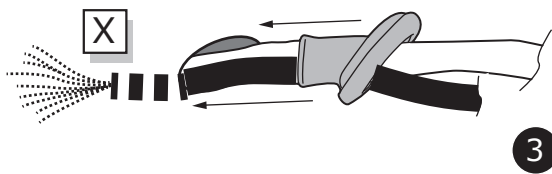

3

Fig 5

INSTALLATION INSTRUCTIONS - A4621ADE00CP

Option 1

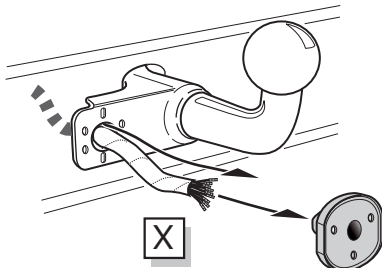

Option 2

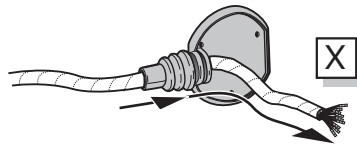

Option 3

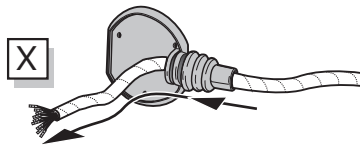

Fig A

- Ⓓ Anschluss Steckdose
- Ⓕ Connection de la prise
- Ⓔ Contactdoos aansluiting
- Ⓖ Socket connection
- Ⓔ Conexión de la caja de enchufe
- Ⓘ Allaccio zoccolo
- Ⓔ Anslutning kontaktdosa
- Ⓒ Objímkový konektor
- Ⓓ Stikdåse forbindelse
- Ⓕ Pistorasia liitäntä
- Ⓖ Υποδοχή σύνδεσης
- Ⓓ Tilkobling koblingsboks
- Ⓖ Połączenie przez gniazdo
- Ⓓ Подключение розетки
- Ⓖ Pripojenie k zásuvke



Pag. 18

INFO

Option 1

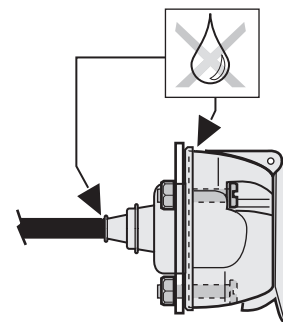
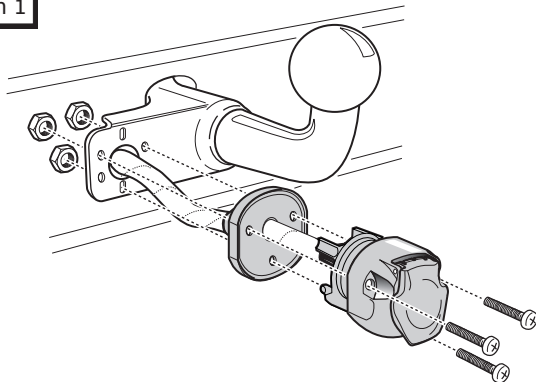
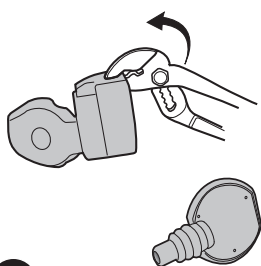
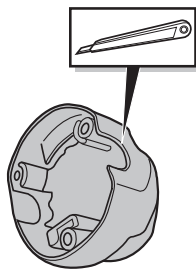

Fig B

Option 2



1



2

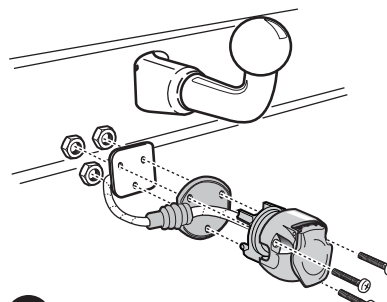

3

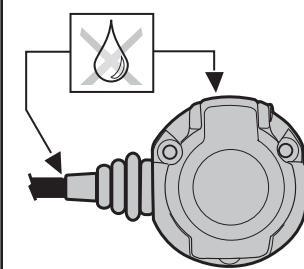

4

Fig C

Option 3

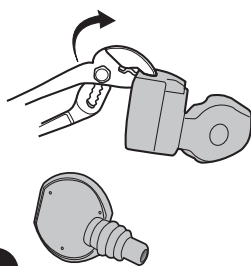

1

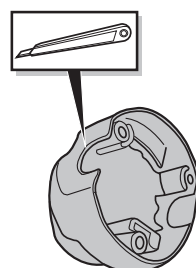

2

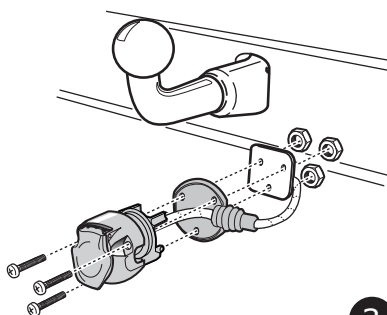

3

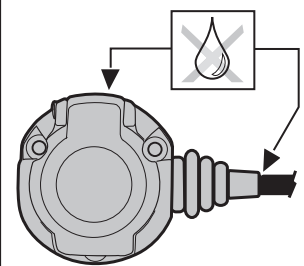

4

Fig D

INSTALLATION INSTRUCTIONS - A4621ADE00CP

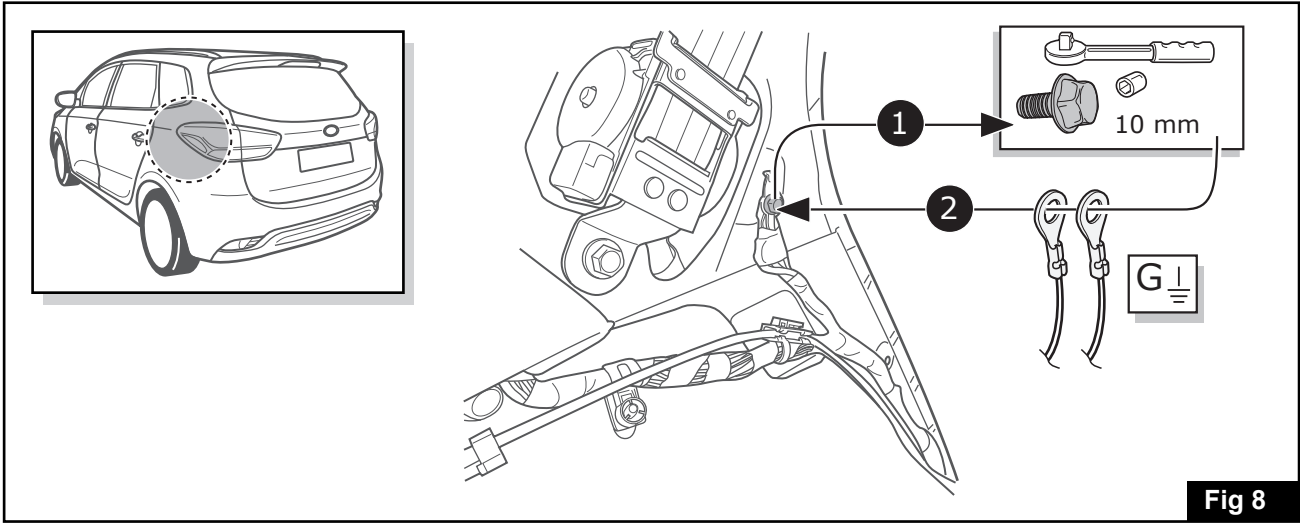
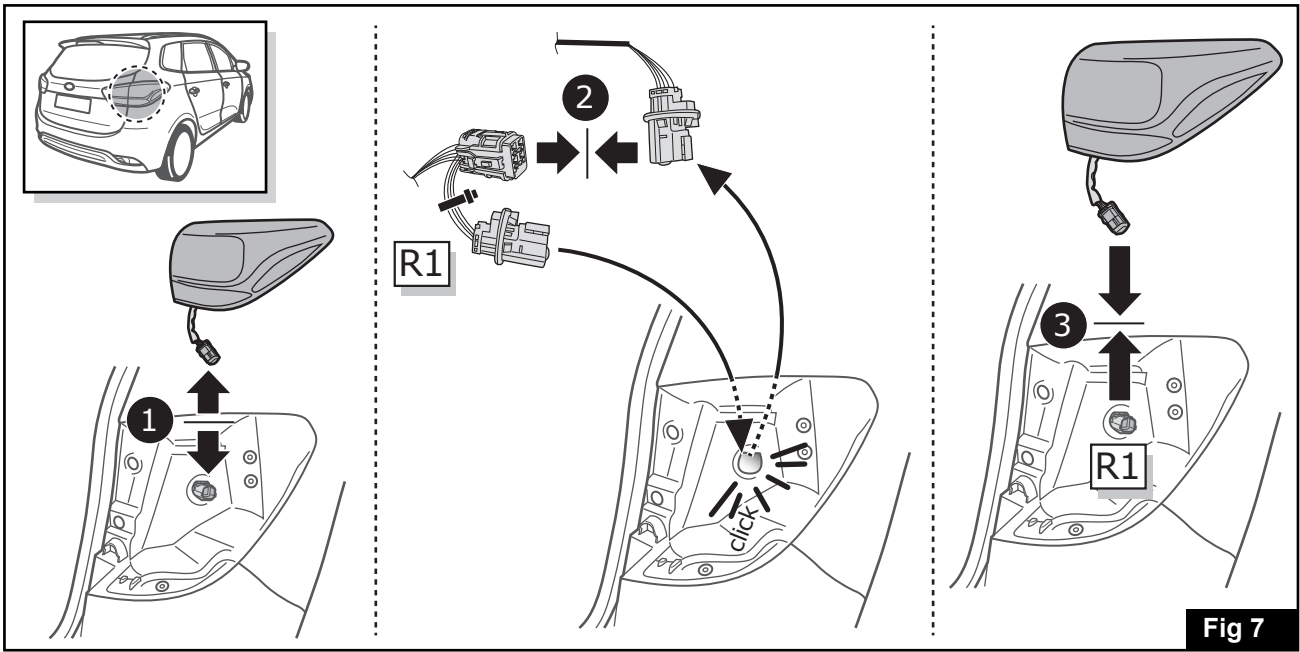
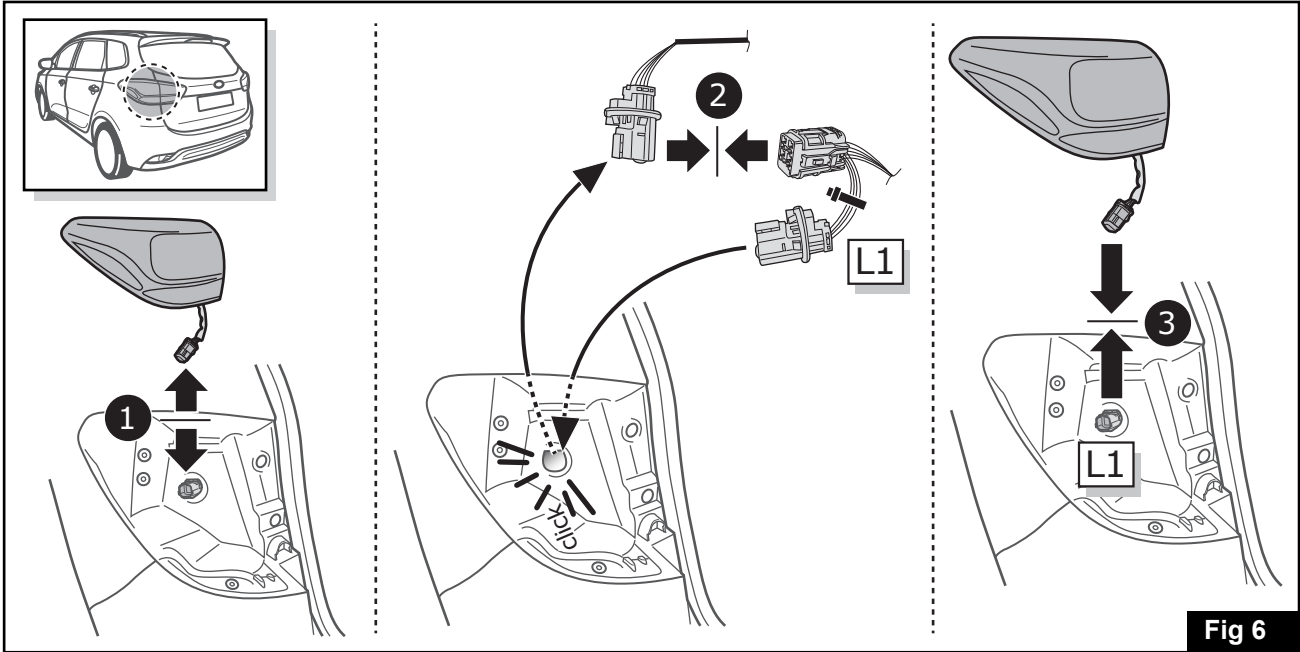

INSTALLATION INSTRUCTIONS - A4621ADE00CP

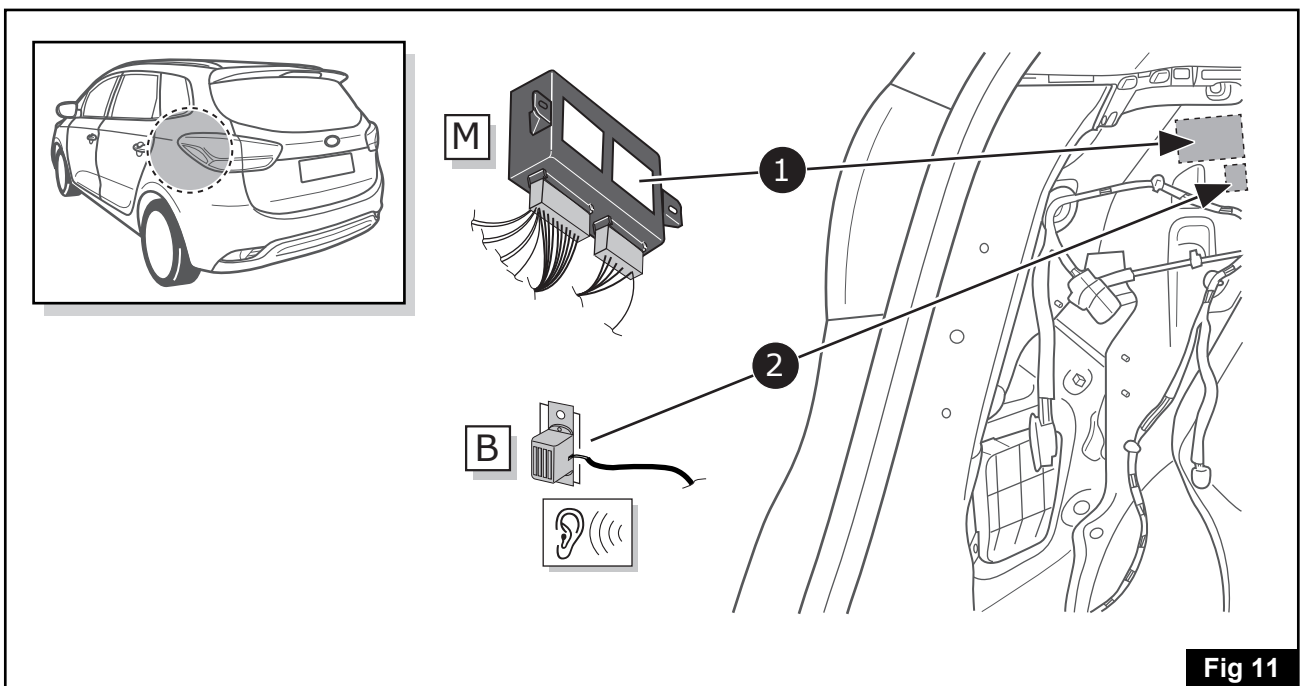
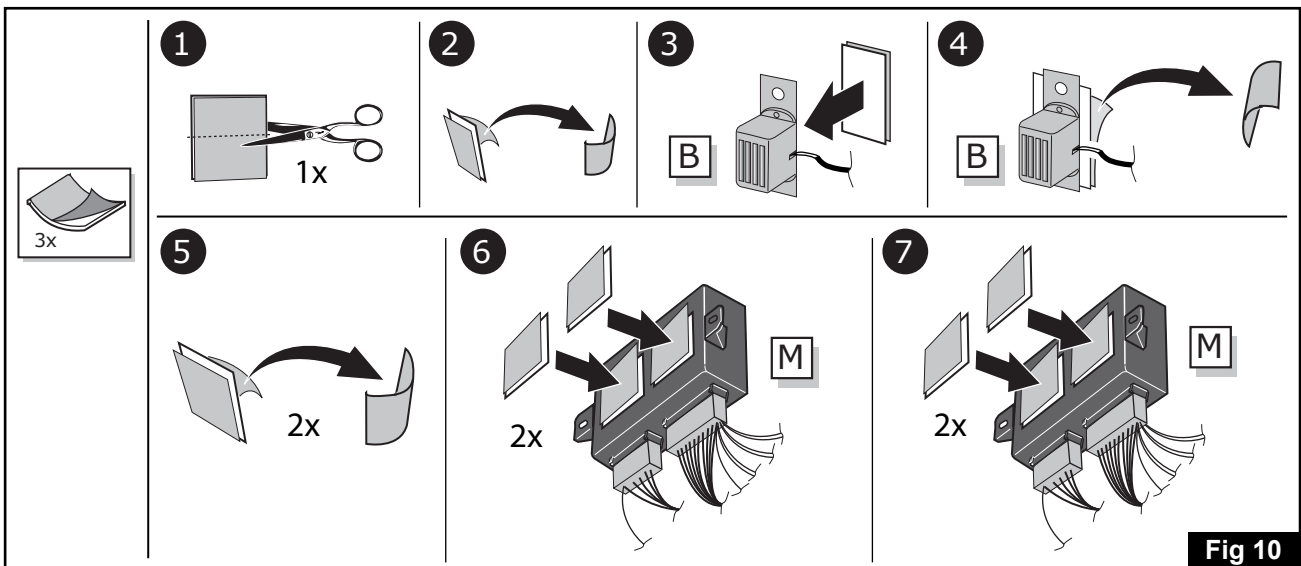
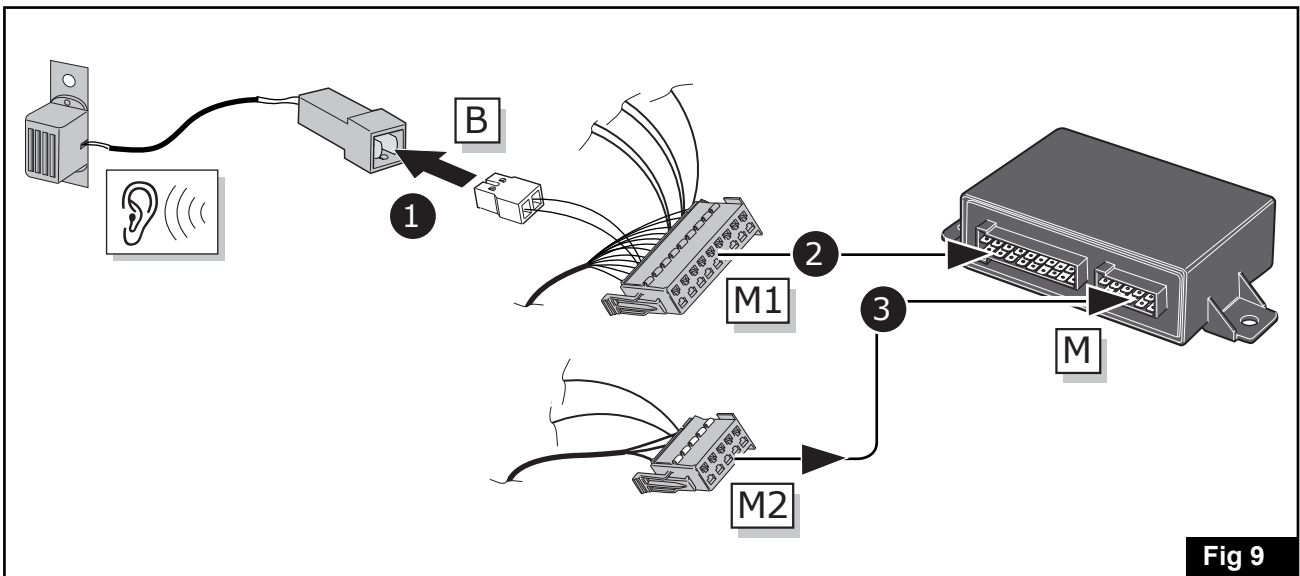

INSTALLATION INSTRUCTIONS - A4621ADE00CP

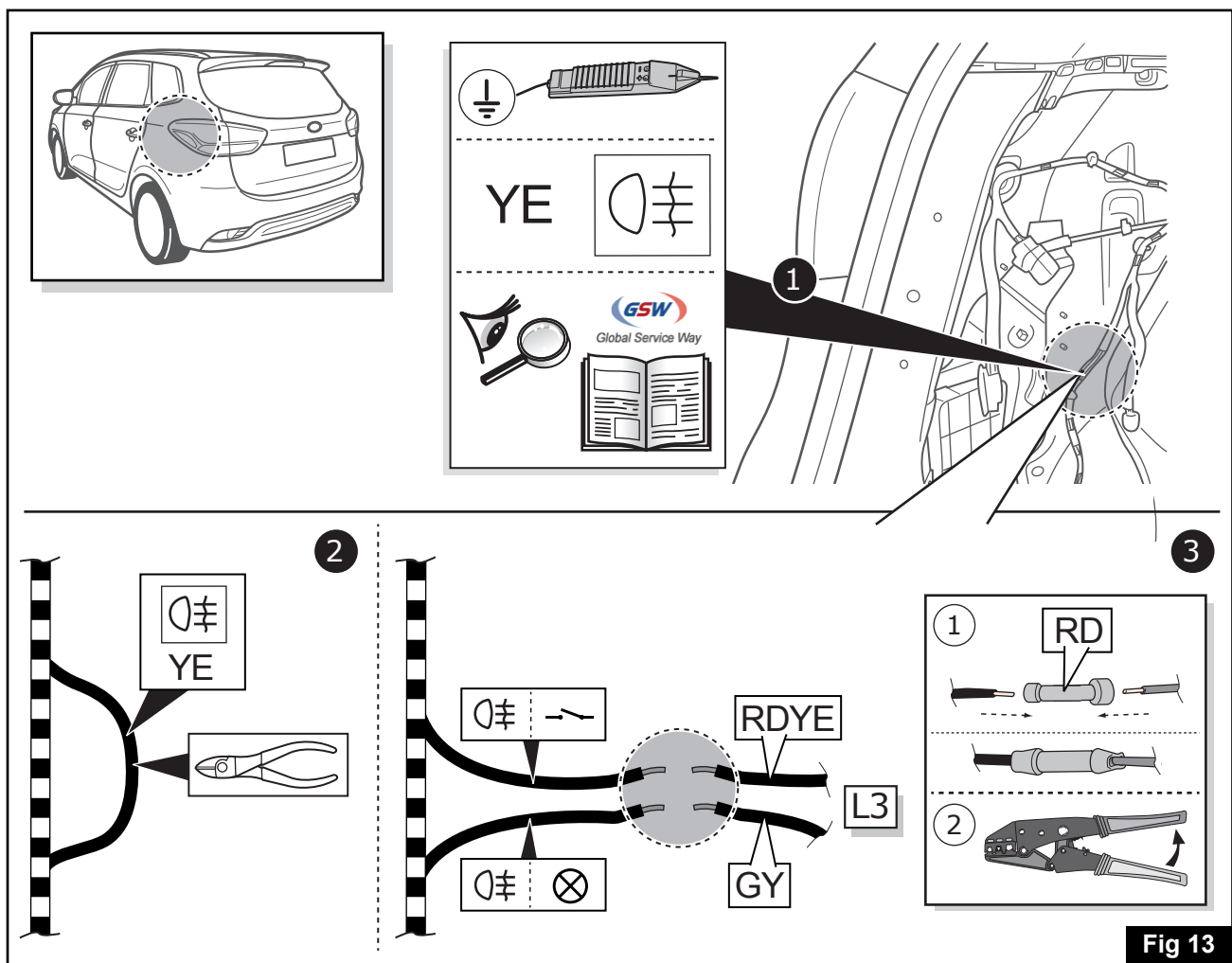
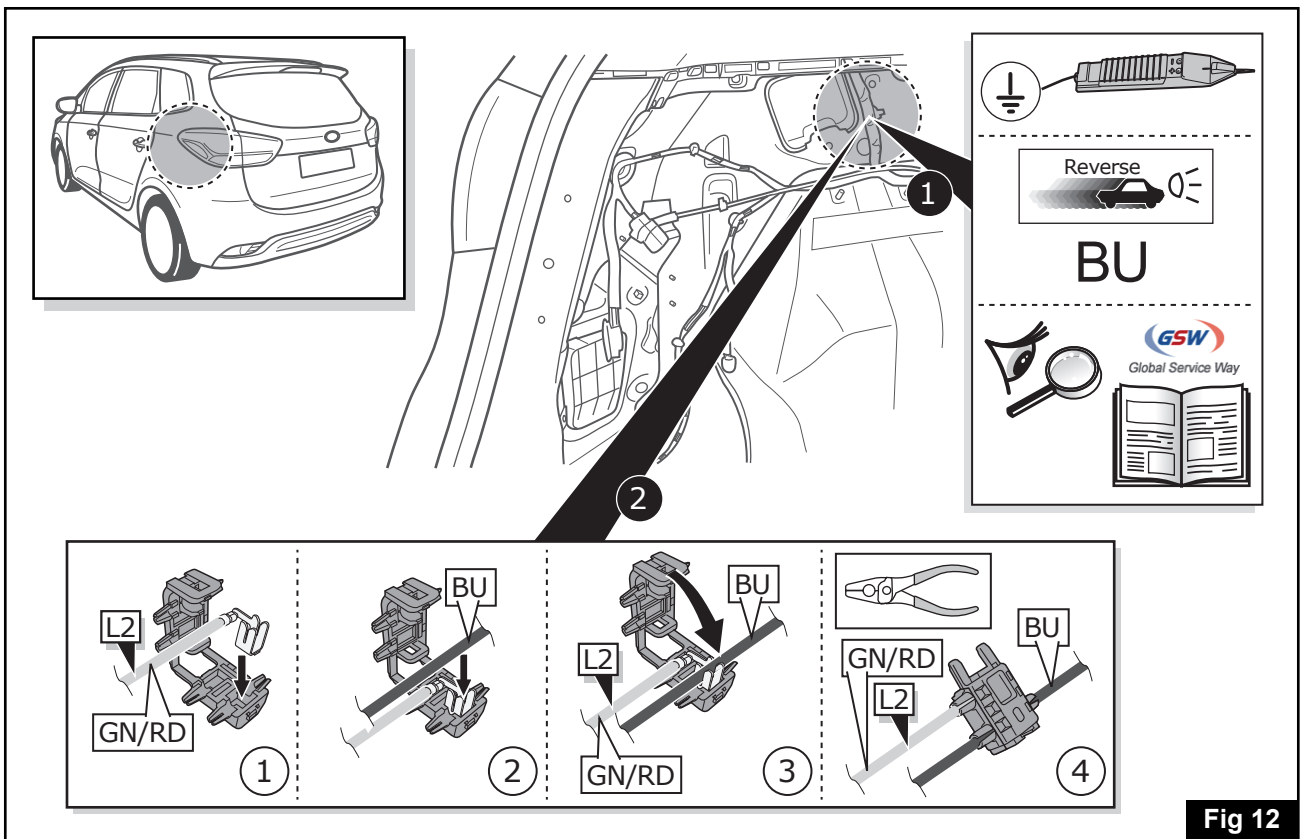

INSTALLATION INSTRUCTIONS - A4621ADE00CP

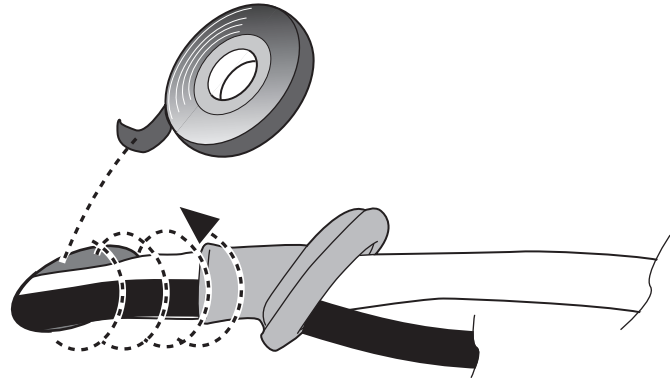
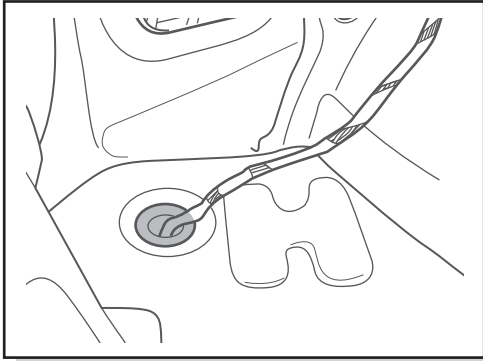

Fig 14

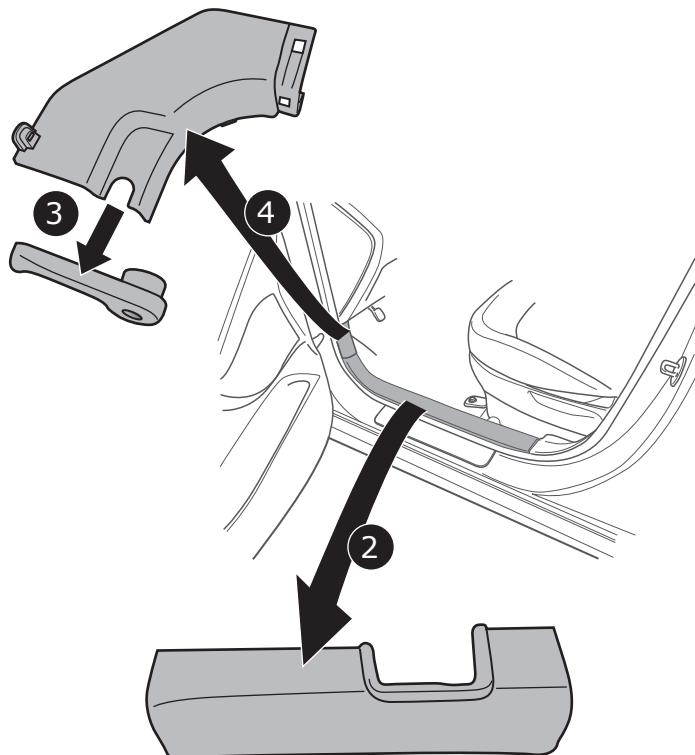
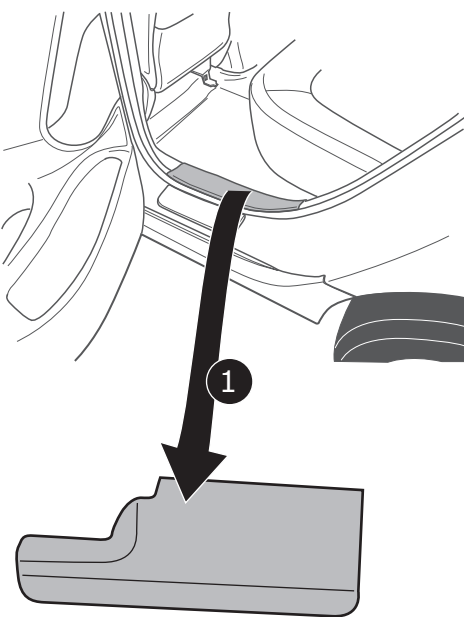
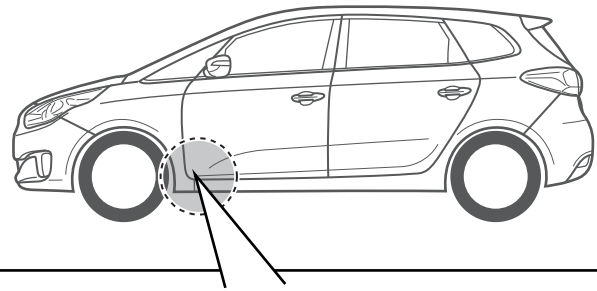
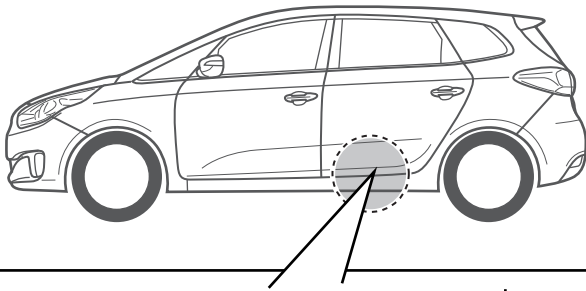
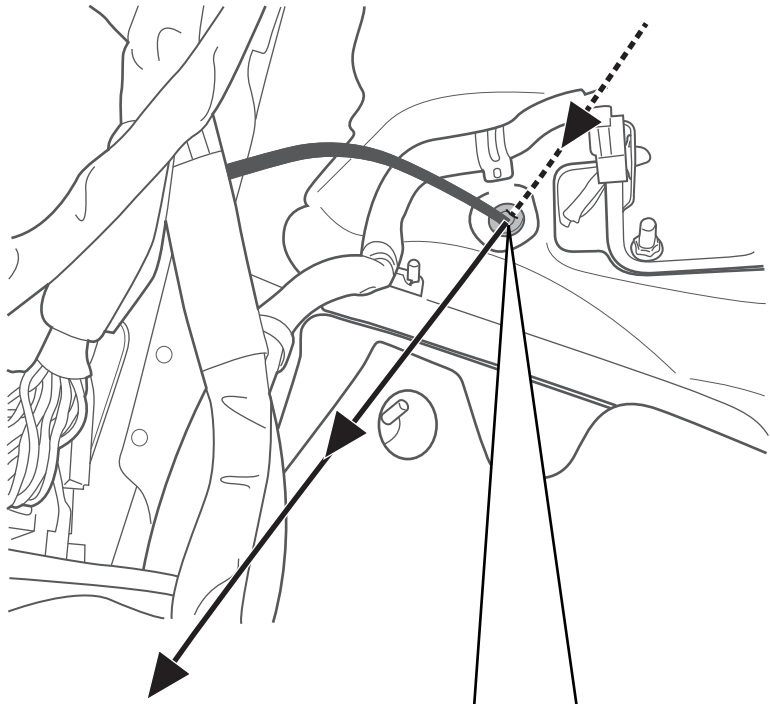
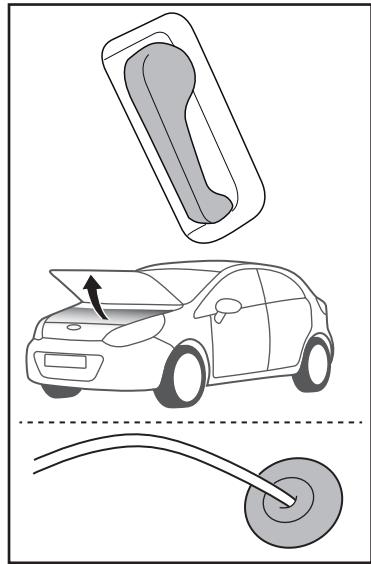
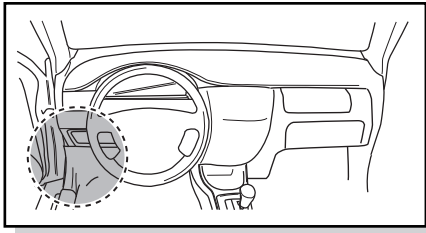
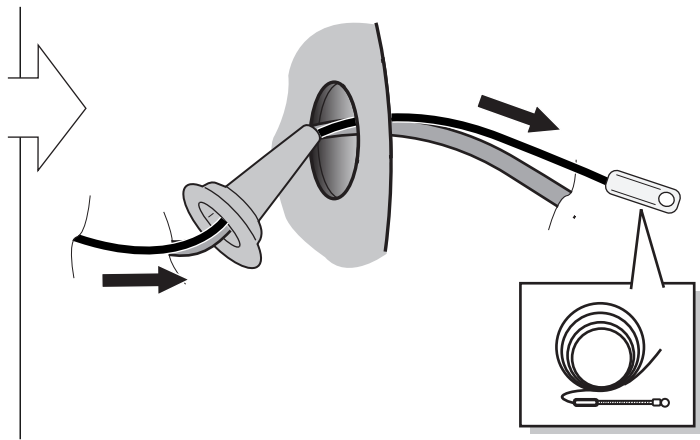
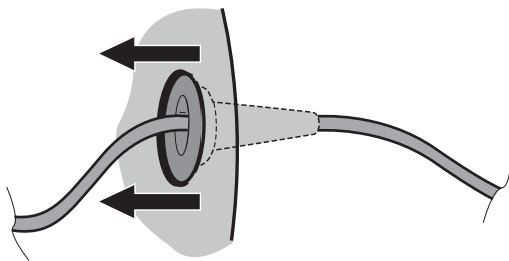

Fig 15

INSTALLATION INSTRUCTIONS - A4621ADE00CP



1



2

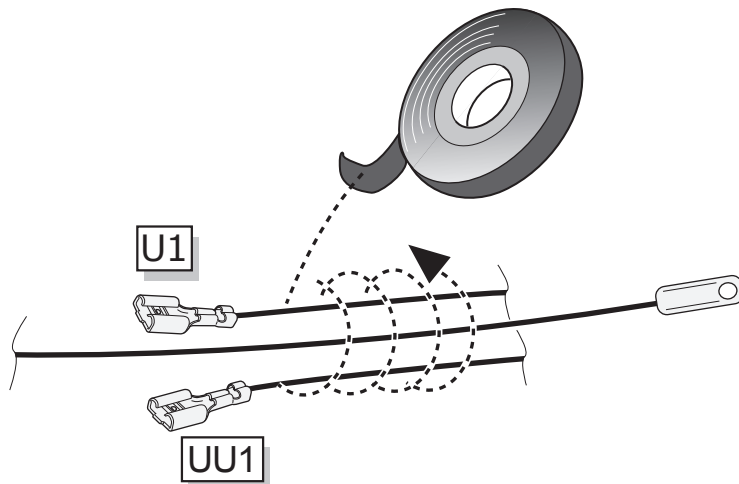
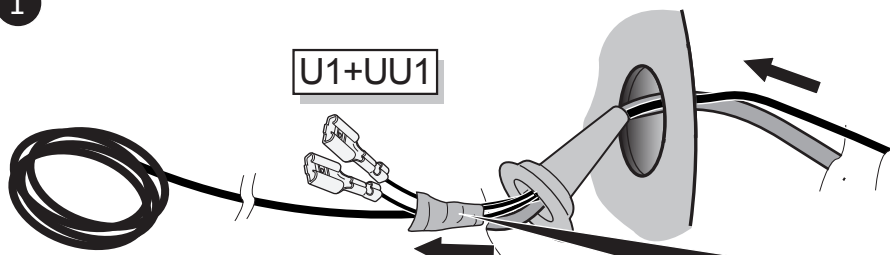

Fig 16

INSTALLATION INSTRUCTIONS - A4621ADE00CP

1



- DE Klebeband entfernen
- FR Enlevez Ruban adhésif
- NL Tape verwijderen
- GB Remove tape
- ES Retirar la cinta adhesiva
- IT Rimuovere il nastro adesivo
- SE Avlägsna klisterbandet
- CZ Odstraňte pásku
- DK Aftag tapen
- FI Poista teippi
- GR Αφαιρέστε την ταινία
- NO Fjern limbåndet
- PL Zdjąć taśmę
- RU Удаление ленты
- SK Odstráňte pásku

2

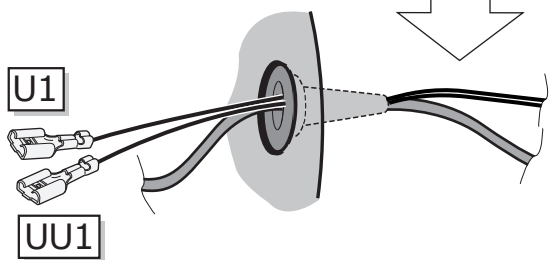
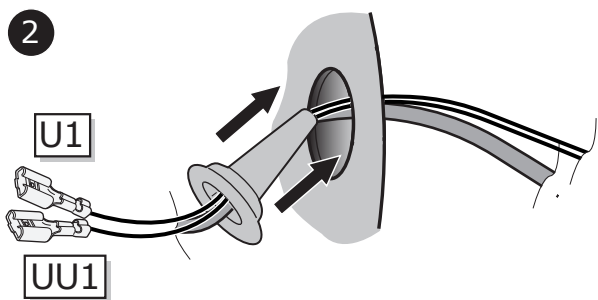

3

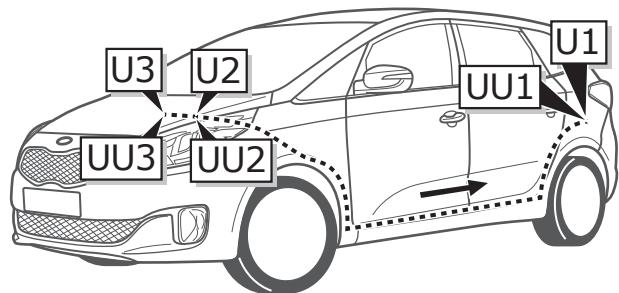
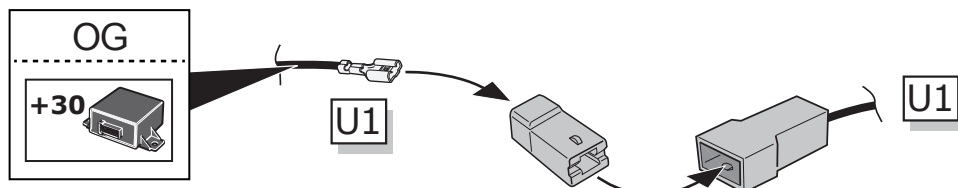

Fig 17

1



2

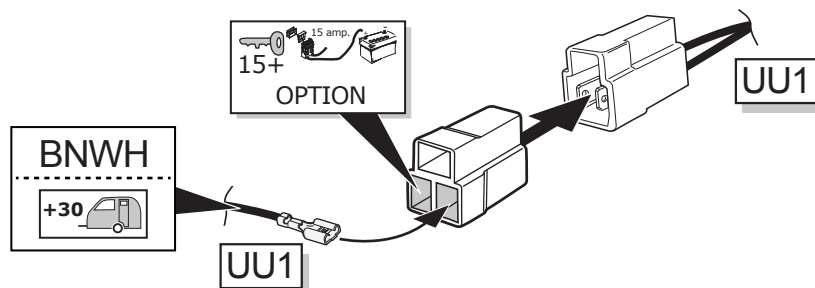

Fig 18

INSTALLATION INSTRUCTIONS - A4621ADE00CP

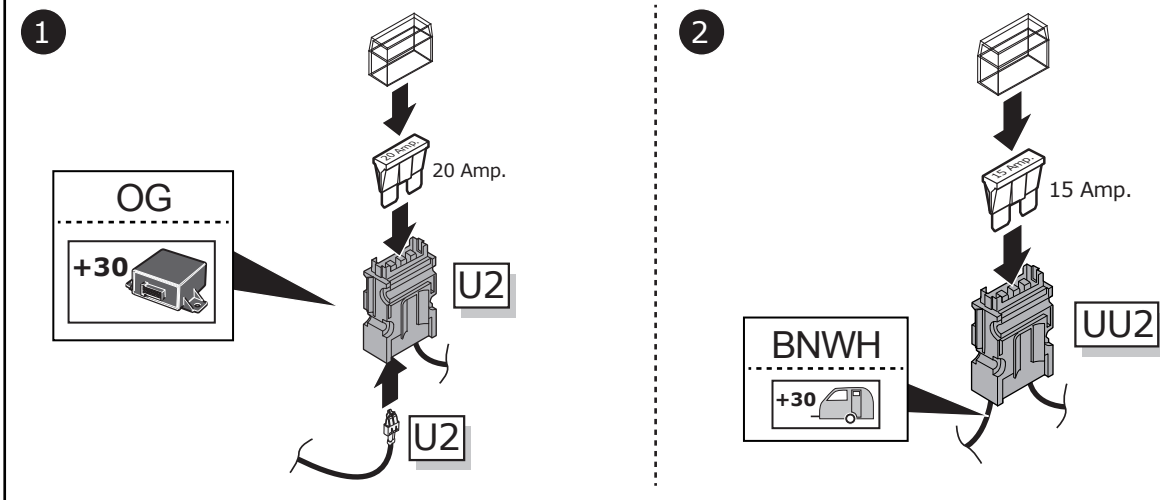

Fig 18

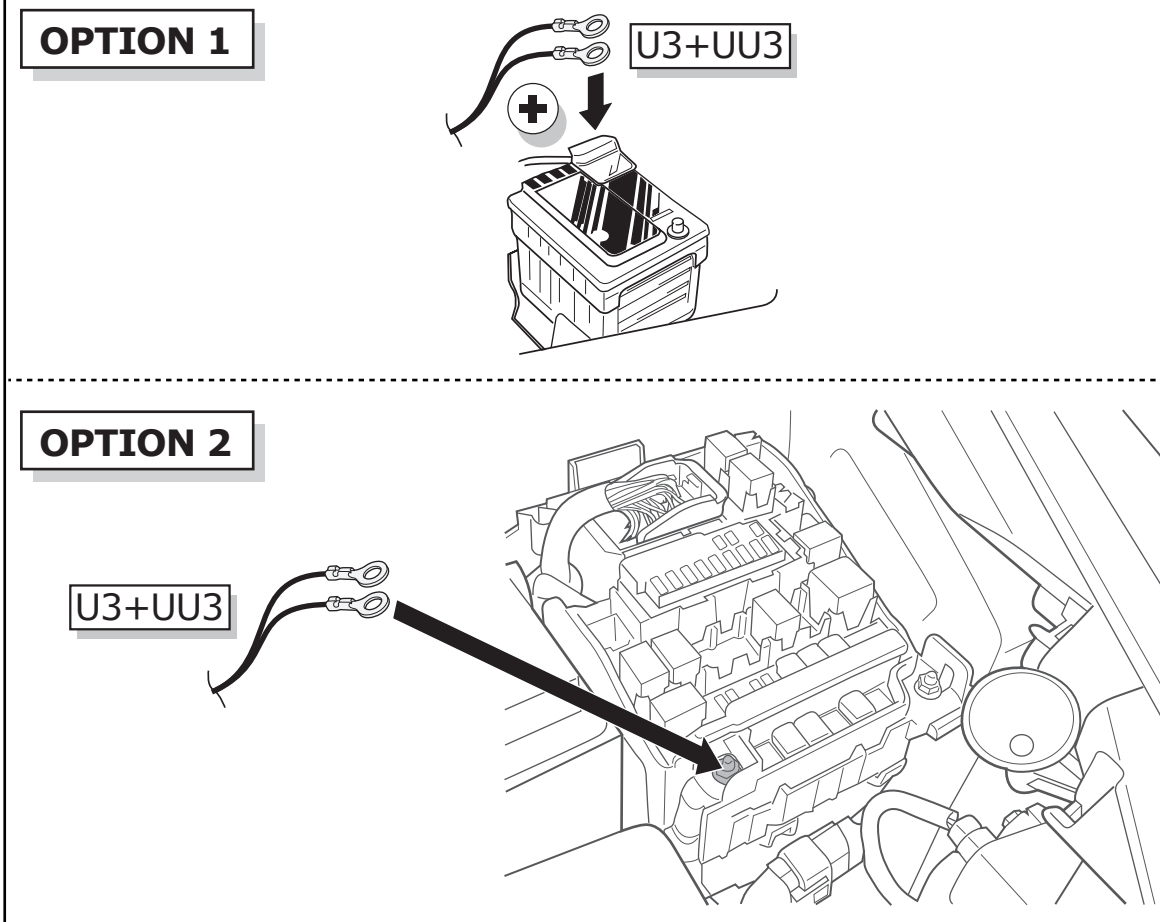

Fig 19

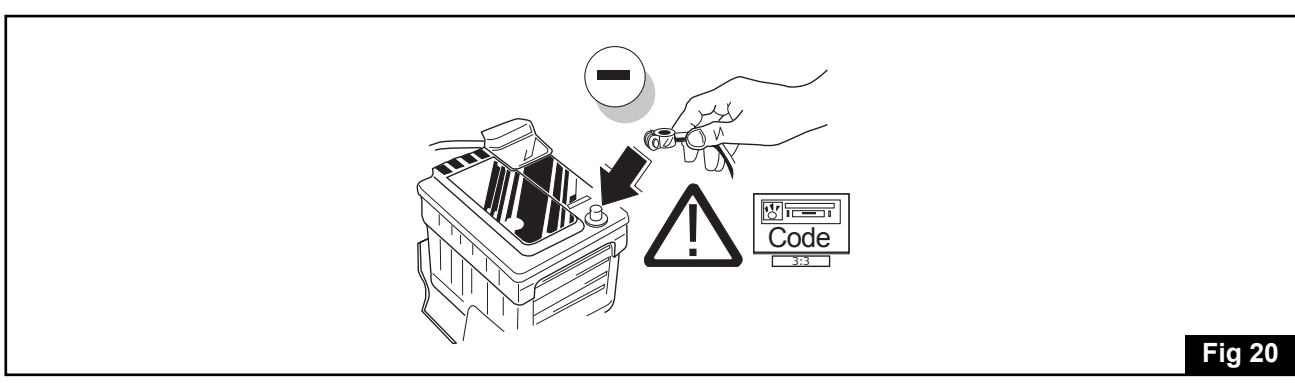

Fig 20

INSTALLATION INSTRUCTIONS - A4621ADE00CP

- !**
- (DE)** FUNKTIONEN KONTROLLIEREN MIT EINEM PRÜFGERÄT MIT WIDERSTAND ODER MIT LEUCHTEN MIT DER GENAUEN WATTZAHL!
 - (FR)** CONTRÔLER LES FONCTIONS AVEC UNE BOÎTE DE TEST AVEC DE LA CHARGE OU DES LAMPES AVEC LA QUANTITÉ CORRECTE DE WATT!
 - (NL)** CONTROLEER FUNCTIES MET EEN TESTER MET BELASTING OF LAMPEN MET DE JUISTE WATTAGE!
 - (GB)** TEST ALL CIRCUIT FUNCTIONS WITH A TESTBOX WITH THE CORRECT POWER LOAD FOR EACH UNIT. A TESTBOX ON WHICH ONLY LEDs ARE USED CAN NOT BE USED IN THIS CASE
 - (ES)** ¡CONTROLAR FUNCIONES CON UN TESTER CON CARGA O LUCES CON EL CORRECTO WATTAJE!
 - (IT)** CONTROLLA FUNZIONI CON UN TESTER CON CARICO O LAMPADE DEL GIUSTO WATT-TAGGIO!
 - (SE)** KONTROLLERA FUNKTIONERNA MED EN TESTARE MED BELASTNING ELLER LAMPOR MED RÄTT WATT-VÄRDE!
 - (CZ)** OVĚŘTE FUNKCE POMOCÍ TESTOVACÍHO BOXU NEBO SVĚTEL S PŘÍSLUŠNÝM VÝKONEM!
 - (DK)** CHECK FUNKTIONERNE MED EN TESTBOKS, MED BELASTNING ELLER MED LYGTER MED DET KORREKTE ANTAL WATT!
 - (FI)** TARKISTA TOIMINNOT KÄYTTÄMÄLLÄ TESTILAITE, JOSSA ON OIKEATEHOINEN KUORMITUS TAI OIKEATEHOISET LAMPUT!
 - (GR)** ΕΛΕΓΕΤΕ ΤΙΣ ΛΕΙΤΟΥΡΓΙΕΣ ΜΕ ΈΝΑ ΚΙΒΩΤΙΟ ΔΟΚΙΜΗΣ ΜΕ ΦΟΡΤΙΟ Ή ΛΑΜΠΗΡΕΣ ΣΩΣΤΗΣ ΠΟΣΟΤΗΤΑΣ ΒΑΤ!
 - (NO)** KONTROLER FUNKSJONENE MED EN TESTER MED BELASTNING ELLER LYSFÆRER MED RIKTIG WATTVERDI!
 - (PL)** SPRAWDŹ FUNKCJE UŻYWAJĄC SKRZYNKI TESTOWEJ Z OBCIĄŻENIEM LUB PODŁĄCZONYMI ŻARÓWKAMI O ODPWIEDNIEJ MOCY!
 - (RU)** ПРОВЕРТЕ РАБОТУ ФУНКЦИЙ С ПОМОЩЬЮ ИСПЫТАТЕЛЬНОГО ПРИБОРА ЭЛЕКТРИЧЕСКОЙ НАГРУЗКОЙ ИЛИ С ЛАМПАМИ С СООТВЕТСТВУЮЩЕЙ МОЩНОСТЬЮ (ВАТТ)!
 - (SK)** PREVEŘTE FUNKCIE SKÚŠAČKOU SO ZAŤAŽENÍM ALEBO ŽIAROVKOU SO SPRÁVNÝM PRÍKONOM!

Fig 21

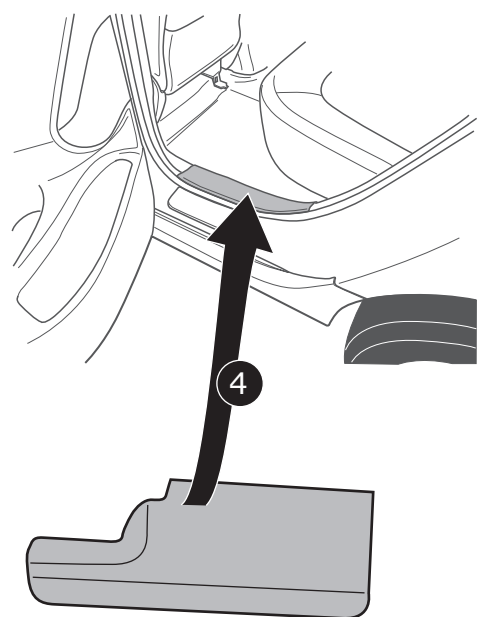
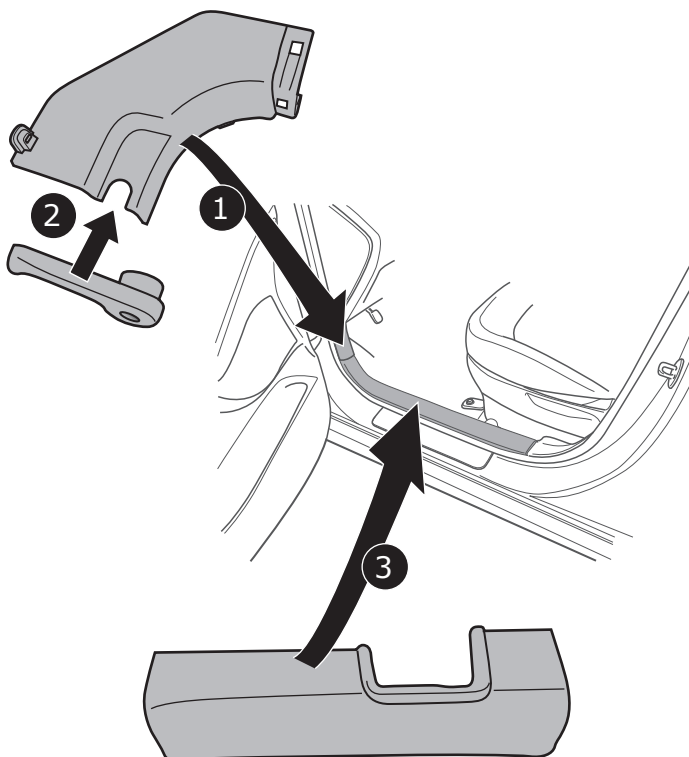
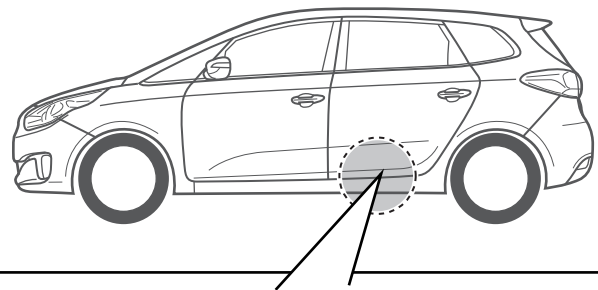
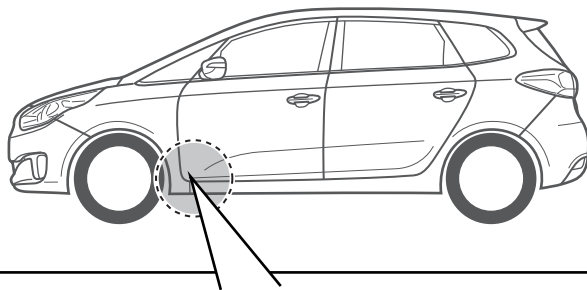
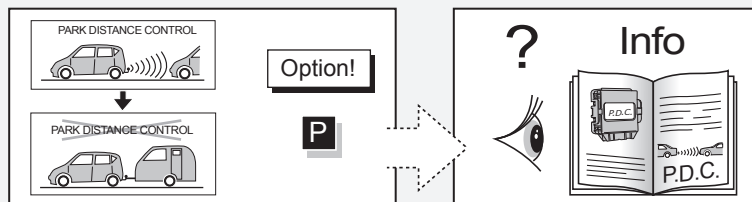
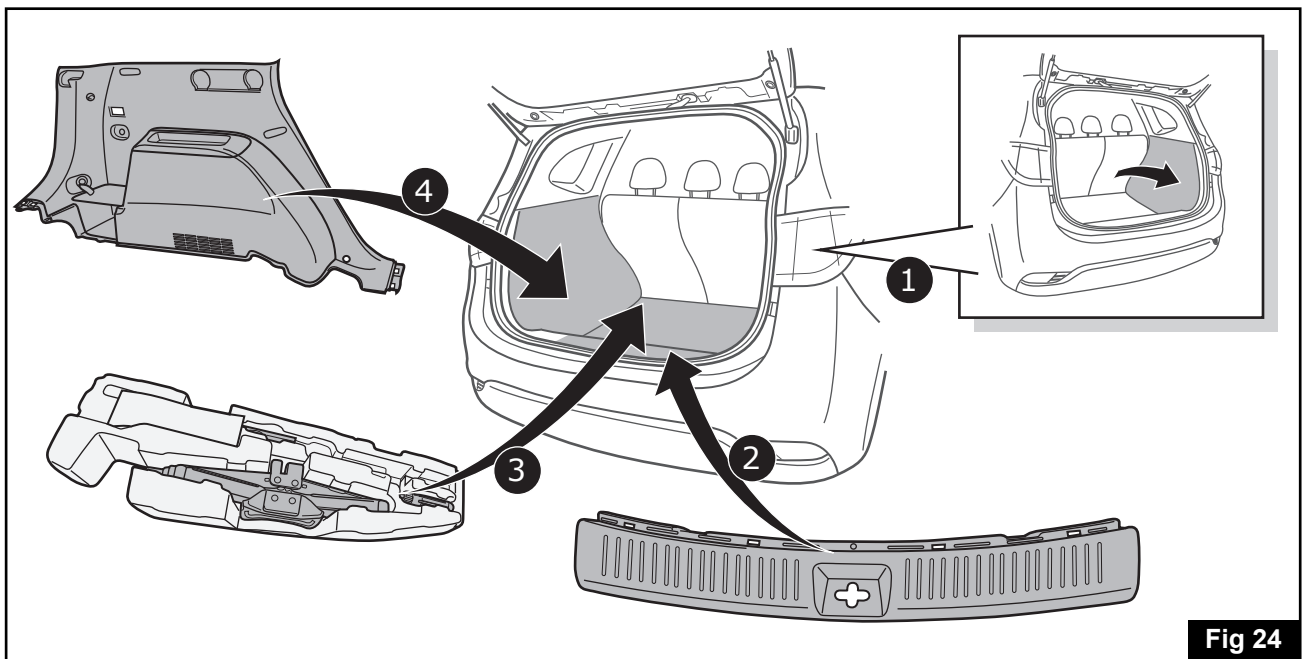
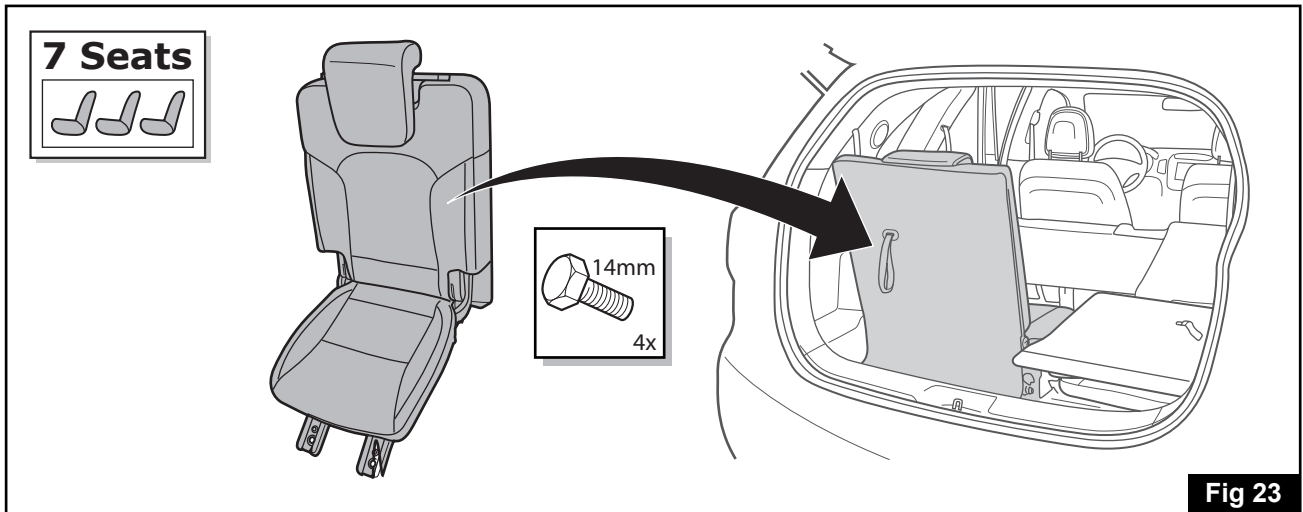
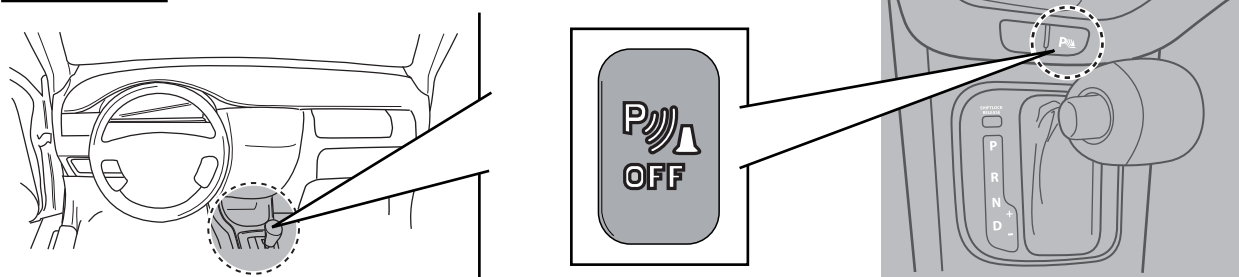

Fig 22

INSTALLATION INSTRUCTIONS - A4621ADE00CP



Option 1 For OEM installed PDC systems



INSTALLATION INSTRUCTIONS - A4621ADE00CP

Option!

P

Normally open

COM

NO

Option 2

For KIA Accessory PDC systems only (Cobra Systems)

1

DE Schwarz	DK Sort
FR Noir	FI Musta
NL Zwart	GR Μαύρο
GB Black	NO Svart
ES Negro	PL Czarny
IT Nero	RU черный
SE Svart	SK Čierna
CZ Černá	

DE Blau	DK Blå
FR Blue	FI Sininen
NL Blauw	GR Μπλε
GB Blue	NO Blå
ES Azul	PL Niebieski
IT Blu	RU синий
SE Blå	SK Modrá
CZ Modrá	

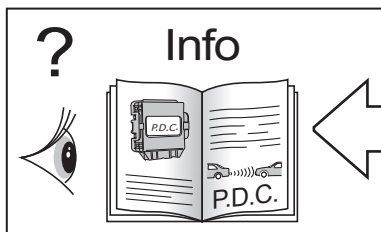
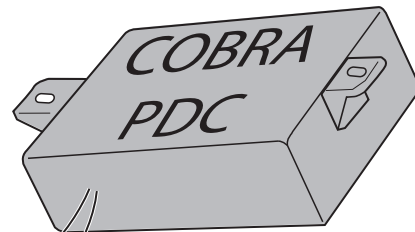

1

2

2

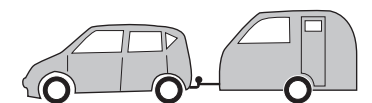

Rear system on

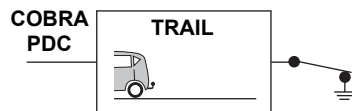

DE Schwarz + Blau	DK Sort + Blå
FR Noir + Blue	FI Musta + Sininen
NL Zwart + Blauw	GR Μαύρο + Μπλε
GB Black + Blue	NO Svart + Blå
ES Negro + Azul	PL Czarny + Niebieski
IT Nero + Blu	RU черный + синий
SE Svart + Blå	SK Čierna + Modrá
CZ Černá + Modrá	

Rear system off

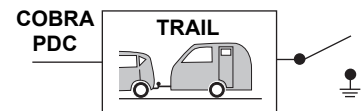

DE Schwarz + Blau	DK Sort + Blå
FR Noir + Blue	FI Musta + Sininen
NL Zwart + Blauw	GR Μαύρο + Μπλε
GB Black + Blue	NO Svart + Blå
ES Negro + Azul	PL Czarny + Niebieski
IT Nero + Blu	RU черный + синий
SE Svart + Blå	SK Čierna + Modrá
CZ Černá + Modrá	

INSTALLATION INSTRUCTIONS - A4621ADE00CP

Normally closed

Option 3

For aftermarket installed PDC systems

1

2

3

Info

1

2

1

Neutral

2

















3

4

TEST

INSTALLATION INSTRUCTIONS - A4621ADE00CP

- (DE) Anschluss Steckdose (GB) Socket connection (SE) Anslutning kontaktdosa (FI) Pistorasia liitäntä (PL) Połączenie przez gniazdo
(FR) Connexion de la prise (ES) Conexión de la caja de enchufe (CZ) Objímkový konektor (GR) Υποδοχή σύνδεσης (RU) Подключение розетки
(NL) Contactdoos aansluiting (IT) Allaccio zoccolo (DK) Stikdåse forbindelsesev (NO) Tilkobling koblingsboks (SK) Pripojenie k zásuvke

																
DIN-ISO 11446	1/L	2	3/31	4/R	5/58-R	52W	6/54	7/58-L	8	9	10	11	12	13	9	
Pmax	21W	2x21W	21W	21W	52W	52W	3x21W	52W	2x21W	180W/ 15Amp.	OPTION					
(DE)	Gelb	Blau	Weiß	Grün	Braun	Braun	Rot (1 mm ²)	Schwarz	Schwarz/ Rot	Braun/ Weiß	Rot (2,5 mm ²)	Weiß	-	Weiß		
(FR)	Jaune	Bleu	Blanc	Vert	Marron	Noir	Rouge (1 mm ²)	Noir	Noir/ Rouge	Marron/ Blanc	Rouge (2,5 mm ²)	Blanc	-	Blanc		
(NL)	Geel	Blauw	Wit	Groen	Bruin	Zwart	Rood (1 mm ²)	Zwart	Zwart/ Rood	Bruin/ Wit	Rood (2,5 mm ²)	Wit	-	Wit		
(GB)	Yellow	Blue	White	Green	Brown	Black	Red (1 mm ²)	Black	Black/ Red	Brown/ White	Red (2,5 mm ²)	White	-	White		
(ES)	Amarillo	Azul	Blanco	Verde	Marrón	Negro	Rojo (1 mm ²)	Negro	Negro/ Rojo	Marrón/ Blanco	Rojo (2,5 mm ²)	Blanco	-	Blanco		
(IT)	Giallo	Blu	Bianco	Verde	Marrone	Nero	Rosso (1 mm ²)	Nero	Nero/ Rosso	Marrone/ Bianco	Rosso (2,5 mm ²)	Bianco	-	Bianco		
(SE)	Gul	Blå	Vit	Grön	Brun	Svart	Röd (1 mm ²)	Svart	Svart/ Röd	Brun/ Vit	Röd (2,5 mm ²)	Vit	-	Vit		
(CZ)	Žlutá	Modrá	Bílá	Zelená	Hnědá	Černá	Červená (1 mm ²)	Černá	Černo/ Červená	Hnědo/ Bílá	Červená (2,5 mm ²)	Bílá	-	Bílá		
(DK)	Gul	Blå	Hvid	Grøn	Brun	Sort	Rød (1 mm ²)	Sort	Sort/ Rød	Brun/ Hvid	Rød (2,5 mm ²)	Hvid	-	Hvid		
(FI)	Keltainen	Sininen	Valkoinen	Vihreä	Ruskea	Musta	Punainen (1 mm ²)	Musta	Musta/ Punainen	Ruskea/ Valkoinen	Punainen (2,5 mm ²)	Valkoinen	-	Valkoinen		
(GR)	Κίτρινο	Μπλε	Λευκό	Πράσινο	Καφέ	Μαύρο	Κόκκινο (1 mm ²)	Μαύρο	Μαύρο/ Κόκκινο	Καφέ/ Λευκό	Κόκκινο (2,5 mm ²)	Λευκό	-	Λευκό		
(NO)	Gul	Blå	Hvit	Grønn	Brun	Svart	Rød (1 mm ²)	Svart	Svart/ Rød	Brun/ Hvit	Rød (2,5 mm ²)	Hvit	-	Hvit		
(PL)	Żółty	Niebieski	Biały	Zielony	Brazowy	Czarny	Czerwonony (1 mm ²)	Czarny	Czarny/ Czerwonony	Brazowy/ Biały	Czerwonony (2,5 mm ²)	Biały	-	Biały		
(RU)	Желтый	Синий	Белый	Зеленый	Коричневый	Черный	Красный (1 mm ²)	Черный	Черный/ Красный	Коричневый/ Белый	Красный (2,5 mm ²)	Белый	-	Белый		
(SK)	Žltá	Modrá	Bielá	Zelená	Hnedá	Čierna	Červená (1 mm ²)	Čierna	Čierna/ Červená	Hnedá/ Bielá	Červená (2,5 mm ²)	Bielá	-	Bielá		