



PART-NO.: 66603ADE00

GENUINE ACCESSORIES

PARKING DISTANCE CONTROL - REAR -

- GB** Installation instructions
- DE** Einbauanleitung
- FR** Instructions de montage
- NL** Inbouwhandleiding
- DK** Monteringsvejledning
- IT** Istruzioni per il montaggio
- NO** Montage vejledning
- PT** Instruções de montagem
- ES** Instrucciones de montaje
- SE** Montageanvisning
- CZ** Návod k instalaci
- FI** Asennusohjeet
- PL** Instrukcja instalacji
- RU** Инструкции по монтажу
- SK** Pokyny pre montáž

PRE-INSTALLATIONS CAUTIONS/NOTES:

GB	We would expressly point out that assembly not carried out properly by a competent installer will result in cancellation of any right to damage compensation, especially the right required by the laws in terms of warranty.	Contents of these kits and their fitting manuals are subject to alteration without notice, please ensure that these instructions are read and fully understood before commencing installation.
DE	Beachten Sie bitte, dass bei Schäden in Folge unsachgemäßen Einbaus sämtliche Garantieansprüche erlöschen, insbesondere solche, die das Produkthaftungsgesetz betreffen.	Das Recht zu Änderungen an Inhalt von Montagesatz und Einbauleitungen ohne Vorankündigung bleibt vorbehalten. Lesen Sie vor dem Einbau diese Anleitung sorgfältig und gewissenhaft durch.
FR	Nous tenons à insister tout particulièrement sur le fait que si ce produit n'est pas correctement assemblé par un technicien compétent, aucun droit de compensation ne sera recevable en cas de dommages, notamment les droits en vertu de la loi concernant la responsabilité à l'égard du garant.	Le contenu de ces kits, ainsi que des guides de montage qui les accompagnent est sujet à modifications sans préavis; lisez attentivement ces instructions avant de procéder à l'installation.
NL	We zouden expliciet willen benadrukken dat installatie die niet correct wordt uitgevoerd door een bekwaam installateur kan leiden tot het vervallen van elk recht op schadecompensatie, vooral de compensatie op basis van de garantie.	De inhoud van deze kits en de installatiehandleidingen kunnen worden gewijzigd zonder kennisgeving. Zorg er dus voor dat u deze instructies hebt gelezen en volledig begrijpt voordat u met de installatie begint.
DK	Det skal understreges, at monteringen, der udføres af en ikke-kvalificeret montør, medfører bortfald af enhver ret til erstatning særligt i forbindelse med erstatningskrav, der måtte opstå i kraft af loven om produkt garanti.	Sættens indhold og monteringsvejledninger kan ændres uden varsel, og vejledningerne skal derfor læses og forstås, før monteringen påbegyndes.
IT	Facciamo espressamente notare che il montaggio non corretto eseguito da un installatore competente comporterà la cancellazione di qualsiasi diritto di risarcimento danni da parte dell'utente, in particolare il diritto previsto dalle leggi in termini di garanzia.	I contenuti di questi kit e i relativi manuali di installazione sono soggetti a modifica senza preavviso. Si raccomanda di leggere attentamente e integralmente tali istruzioni e di sincerarsi di averle comprese prima di procedere all'installazione.
NO	Vi bemerker at montasje som ikke utføres korrekt, av en kompetent installator, vil resultere i annullering av all rett til erstatning for enhver skade, spesielt de som oppstår garanti.	Innholdene i disse sett og deres monteringsanvisninger kan endres utes forvarsel. Vennligst påse at disse instruksjonene leses grundig og er forstått innen installasjonsnotens startes.
PT	Gostariámos de ressaltar expressamente que a montagem não realizada corretamente por um instalador competente irá resultar no cancelamento de qualquer direito a indemnização de danos, nomeadamente as que decorrem por virtude do acto de responsabilidade do garantida.	Índice desses kits e seus manuais de montagem estão sujeitos a alteração sem aviso prévio, certifique-se que estas instruções são lidas e completamente entendidas antes de começar a instalação.
ES	Una vez más, hacemos hincapié en el hecho de que si este producto no lo monta correctamente un técnico instalador cualificado, se anulará cualquier derecho de compensación por posibles daños, especialmente los relativos a la legislación vigente sobre este tipo de garantía.	El contenido De los kits y sus correspondientes manuales De montaje están sujetos a posibles modificaciones sin previo aviso. Es importante que lea con atención todas las instrucciones y que las entienda perfectamente antes De iniciar la instalación.
SE	Vi vill uttryckligen meddela att monteringen som inte görs fackmannamässigt av en kompetent montör, kommer att häva rätten till kompensering för skador, speciellt rättigheter enligt lagen om produktansvar garanti.	Innehållet i dessa satser och deras bruksanvisningar kan komma att ändras utan föregående meddelande. Vänligen läs dessa anvisningar noga innan du påbörjar monteringen.
CZ	Upozorňujeme, že instalace provedená nesprávně nebo nekompetentní osobou, ruší veškerá práva na kompenzaci škod, obzvláště způsobených poruchou záruka.	Obsah těchto sad a návody na jejich montáž podléhají změnám bez předchozího upozornění. Prosím, ujistěte se, že jste si pokyny před instalací pečlivě a dostatečně jím rozumíte.
FI	Jos asennuksen suorittaa joku muu kuin pätevä ammattilainen, tämä kumoaa asiakkaan oikeuden vahingonkorvauksiin, erityisesti sellaisiin, jotka perustuvat tuotevastuulakiin.	Kiinnityssarjan sisältöä ja asennusoppaita voidaan muuttaa siltä etukäteen ilmoittamatta. Asiakkaan tulee ennen asennuksen aloittamista perehtyä huolellisesti näihin ohjeisiin.
PL	Pragniemy zwrócić uwagę na fakt, że nieprawidłowy montaż przeprowadzony przez niekompetentne osoby będzie podstawą do unieważnienia wszelkich praw do odszkodowań, w szczególności wynikających z ustaw o odpowiedzialności za gwarancja.	Zawartość opisywanych zestawów i instrukcje ich montażu mogą ulegać zmianom bez powiadomienia, przed rozpoczęciem instalacji należy zapoznać się z instrukcjami i upewnić się, że zostały zrozumiane.
RU	Обратите при повреждениях, возникших в результате неправильного монтажа, истекают все виды гарантии, в частности, касающиеся закона, регулирующего ответственность за качество продукции гарантии.	Право изменения содержания монтажного комплекта и инструкции по установке без предварительного оповещения производителя оставляет за собой. Внимательно прочитайте инструкцию перед тем, как начать установку.
SK	Pripomíname, že v prípade chybnjej inštalácie vykonanej nekompetentným inštalátorom používateľ stráca akýkoľvek nárok na prípadné odškodnenie ako aj akékoľvek zákonní dané právo týkajúce sa zodpovednosti záruky.	Obsahy týchto súprav a príslušné návody na inštaláciu môžu byť zmenené bez predchádzajúceho upozornenia. Odporúčame pozorne si prečítať všetky uvedené pokyny a uistiť sa o ich pochopení ešte pred vykonaním inštalácie.

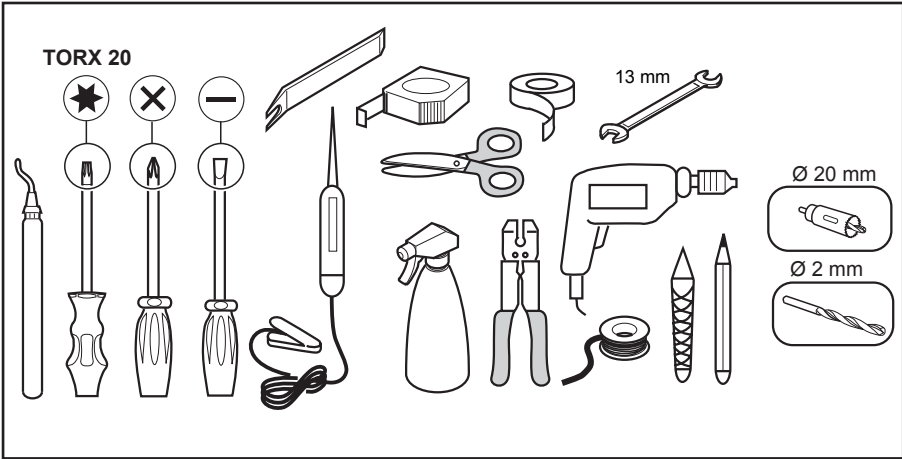

PART LIST - Parking Distance Control (66603ADE00)

GB Part list	IT Elenco componenti	CZ Seznam dílů
DE Einzelteilliste	NO Delliste	FI Osaluettelo
FR Liste de pieces	PT Lista de peças	PL Lista części
NL Onderdelenlijst	ES Lista de componentes	RU Список составных частей
DK Del-list	SE Dellista	SK Zoznam dielov

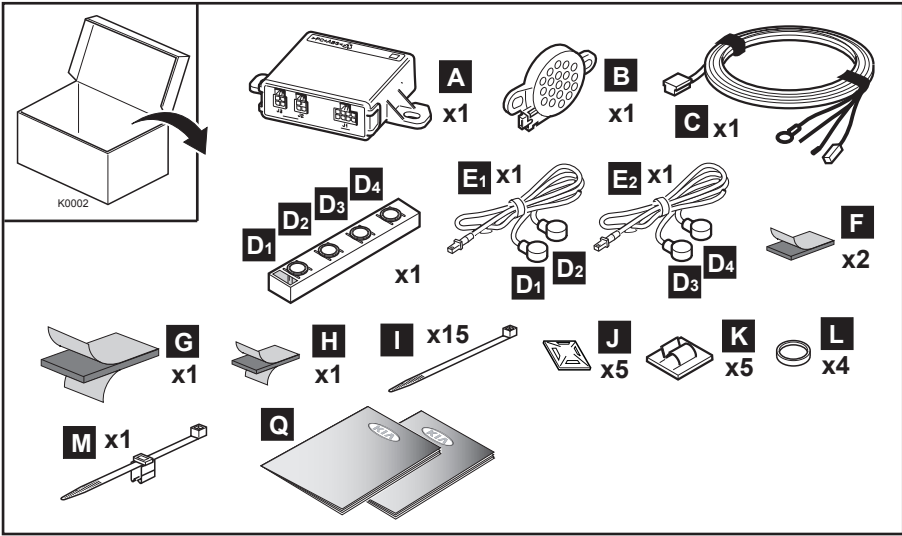

CONNECTIONS - Parking Distance Control (66603ADE00)

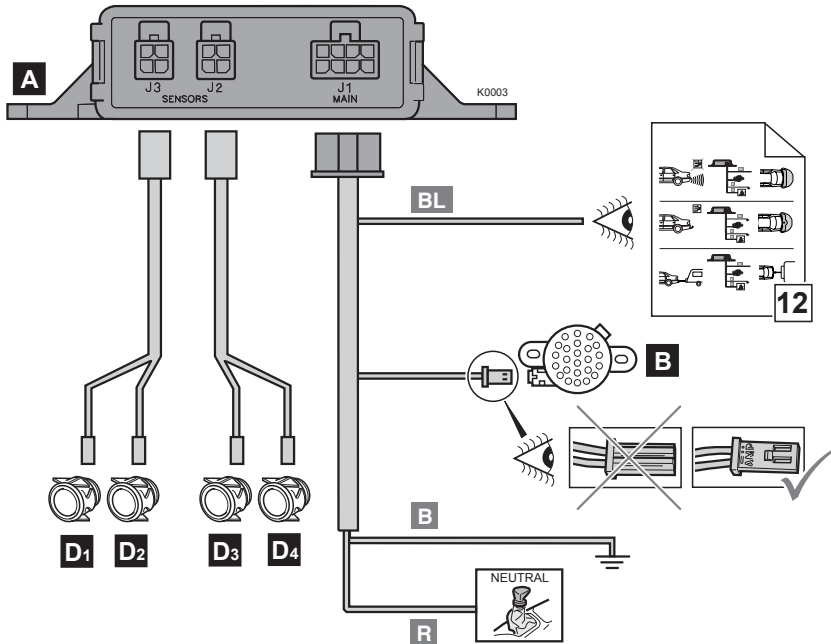

BL	BLUE	BLAU	BLEU	BLAUW	BLÁ	BLU	BLÁ
AZUL	AZUL	BLÁ	MODRÁ	SININEN	NIEBIESKA	СИНИЙ	MODRÁ

B	BLACK	SCHWARZ	NOIR	ZWART	SORT	NERO	SVART
PRETO	NEGRO	SVART	ČERNÁ	MUSTA	CZARNY	ЧЕРНЫЙ	ČERNÝ

R	RED	ROT	ROUGE	ROOD	ROD	ROSSO	ROD
VERMELHO	ROJO	ROD	ČERVENÁ	PUNAINEN	CZERWONY	КРАСНЫЙ	ČERVENÝ

PAINTING - Parking Distance Control (66603ADE00)

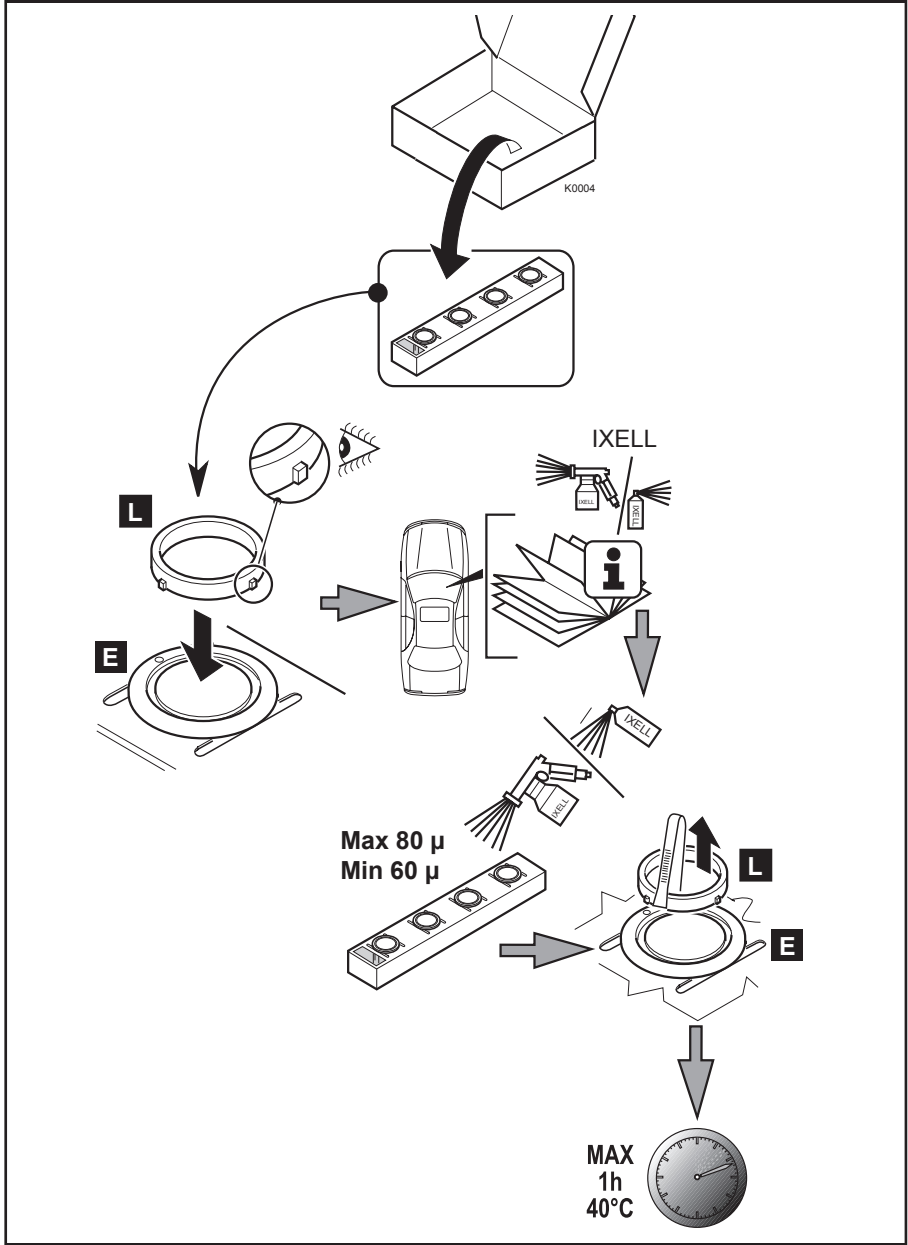

SPECIAL CONFIGURATION

cee'd 5dr 2012

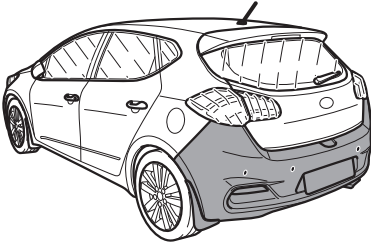

	sensitivity		
3	1	2	2

cee'd wagon 2012

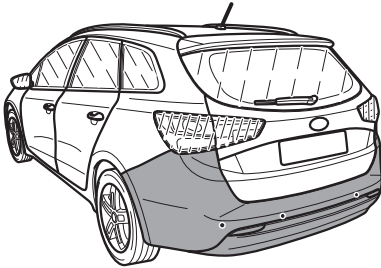

	sensitivity		
3	1	2	3

pro_cee'd + cee'd GT 3dr 2013

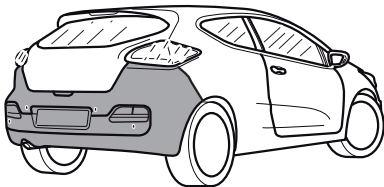



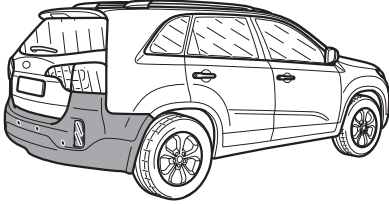

	sensitivity		
3	1	2	4

SPECIAL CONFIGURATION





SORENTO 2012

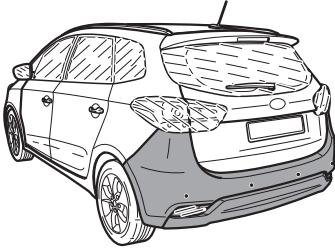

	sensitivity 		
3	1	3	2

CARENS 2013



	sensitivity 		
3	1	3	3

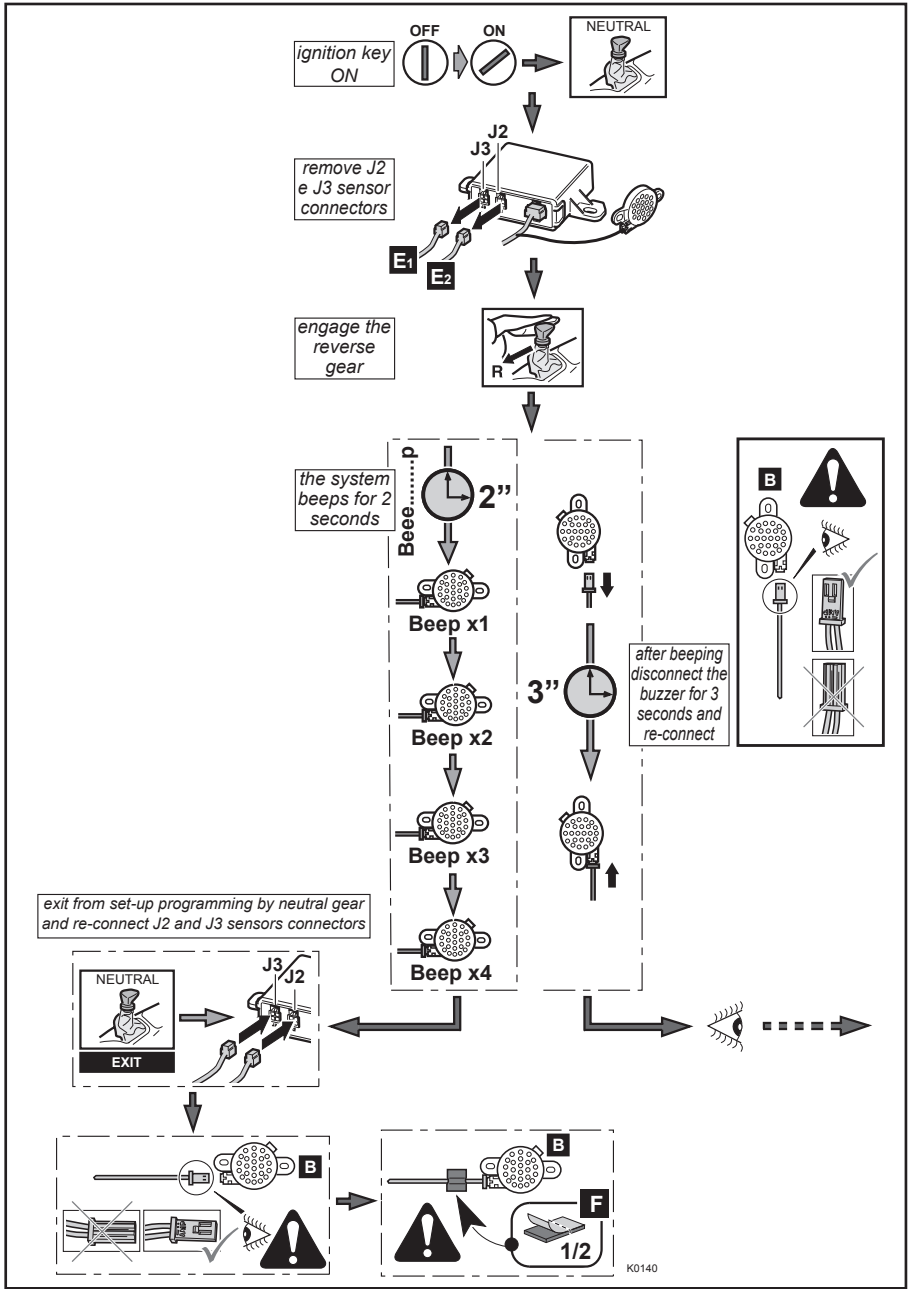

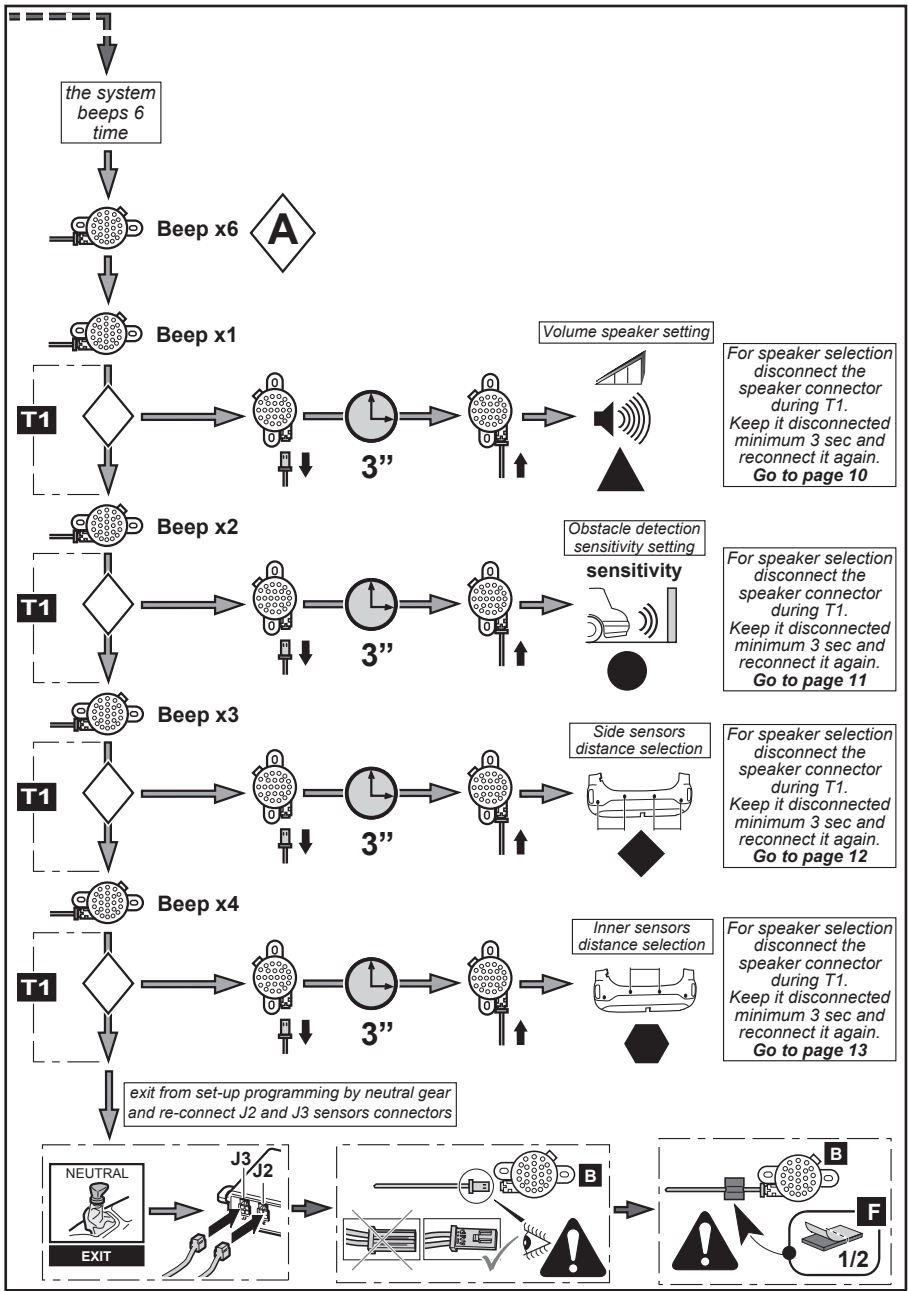

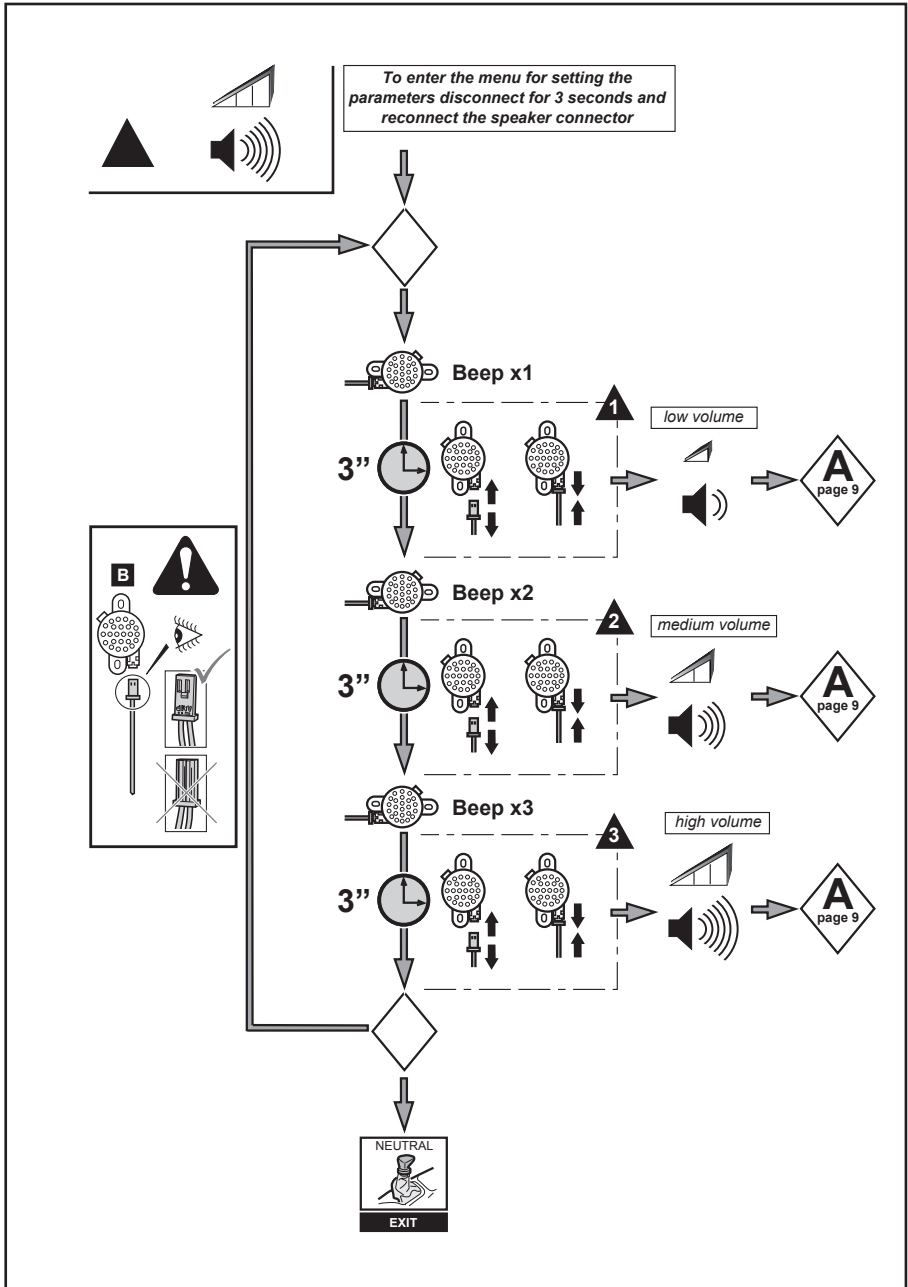

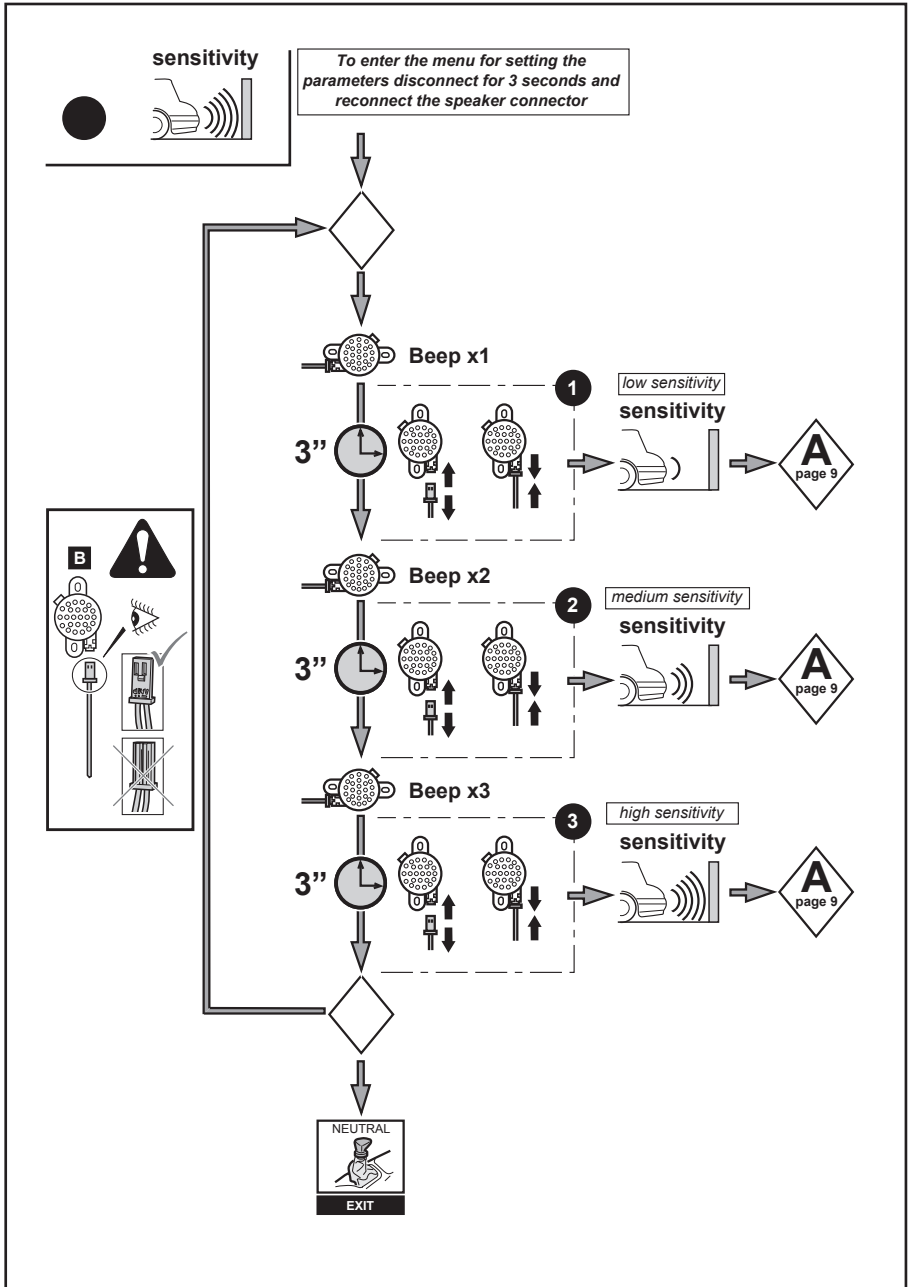

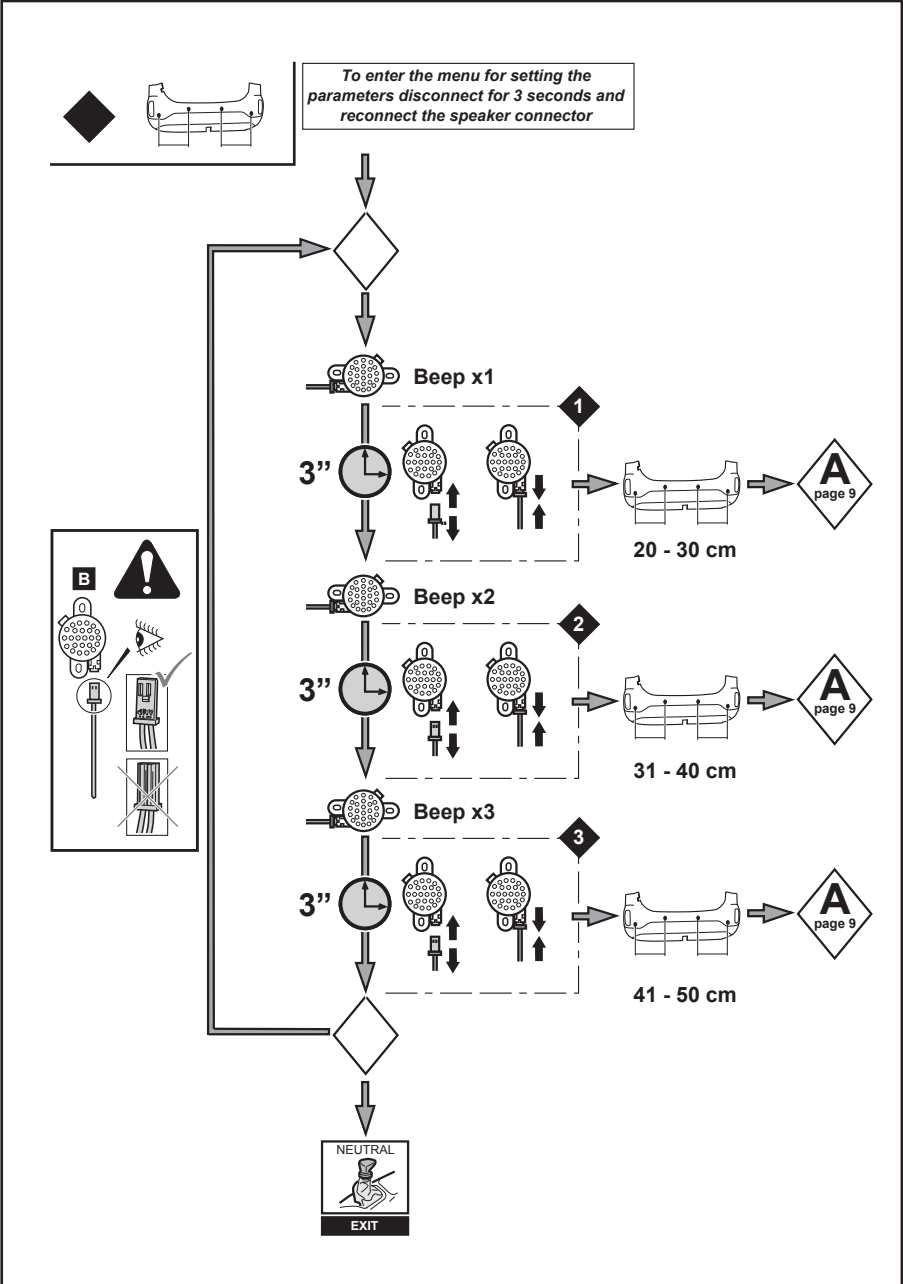

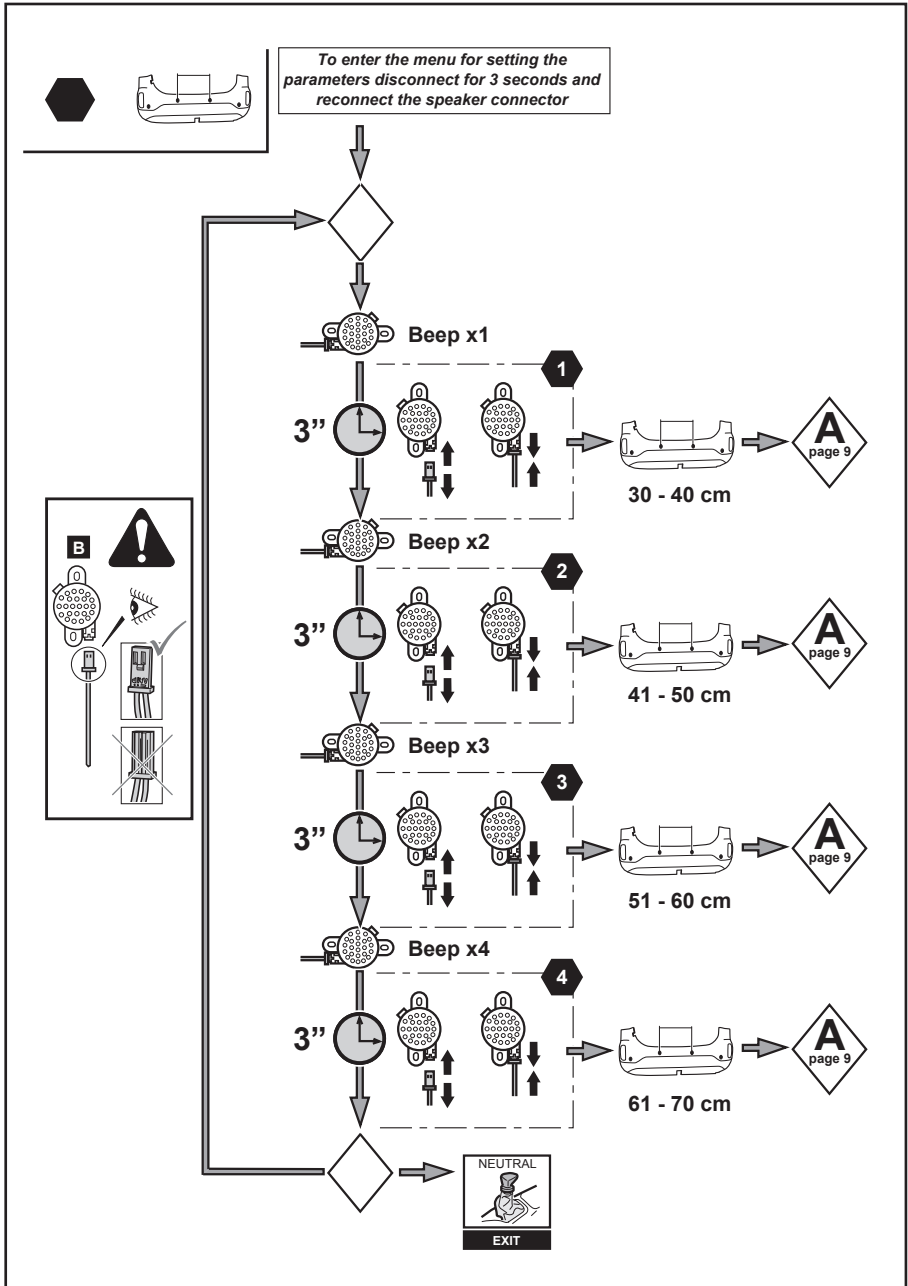

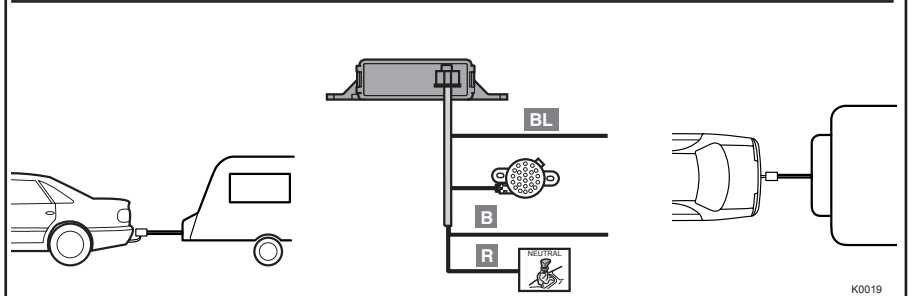
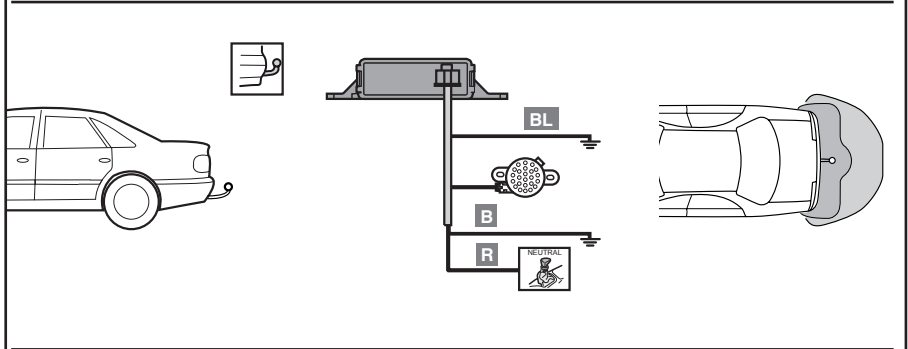
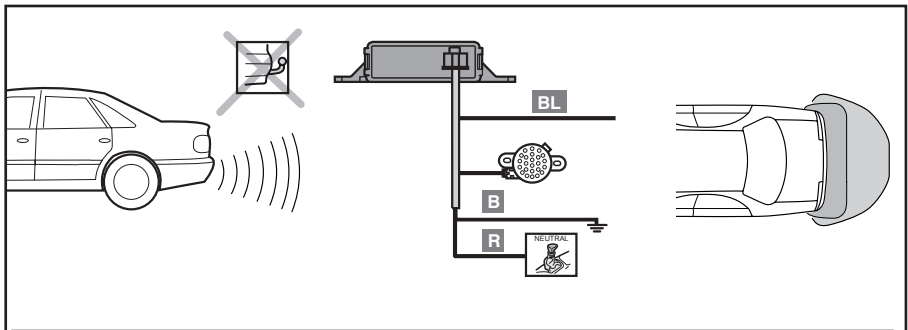

K0019

BL	BLUE	BLAU	BLEU	BLAUW	BLÁ	BLU	BLÁ
AZUL	AZUL	BLÁ	MODRÁ	SININEN	NIEBIESKA	СИНИЙ	MODRÁ

B	BLACK	SCHWARZ	NOIR	ZWART	SORT	NERO	SVART
PRETO	NEGRO	SVART	ČERNÁ	MUSTA	CZARNY	ЧЕРНЫЙ	ČERNÝ

R	RED	ROT	ROUGE	ROOD	ROD	ROSSO	ROD
VERMELHO	ROJO	ROD	ČERVENÁ	PUNAINEN	CZERWONY	КРАСНЫЙ	ČERVENÝ



cee'd 5dr 2012 -----	Pag.	17
cee'd wagon 2012 -----	Pag.	29
pro_cee'd + cee'd GT 3dr 2013 -----	Pag.	41
Sorento 2012 -----	Pag.	55
Carens 2013 -----	Pag.	65



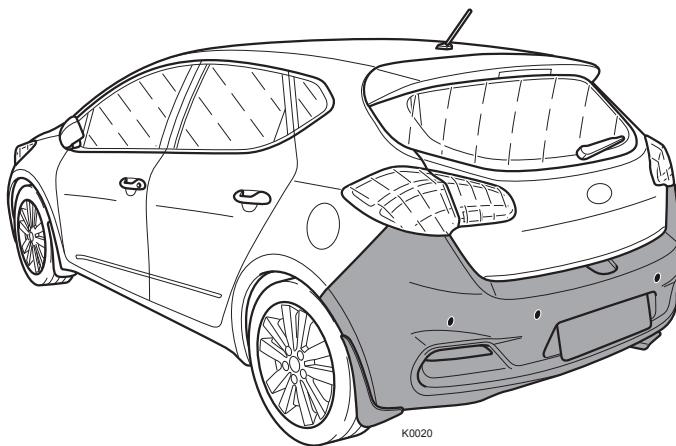

cee'd 5dr 2012

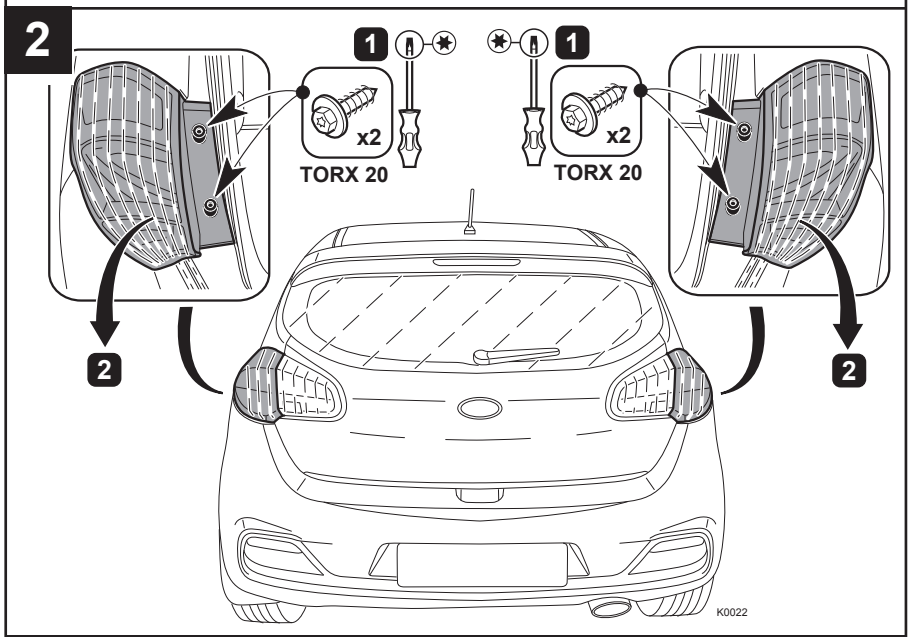
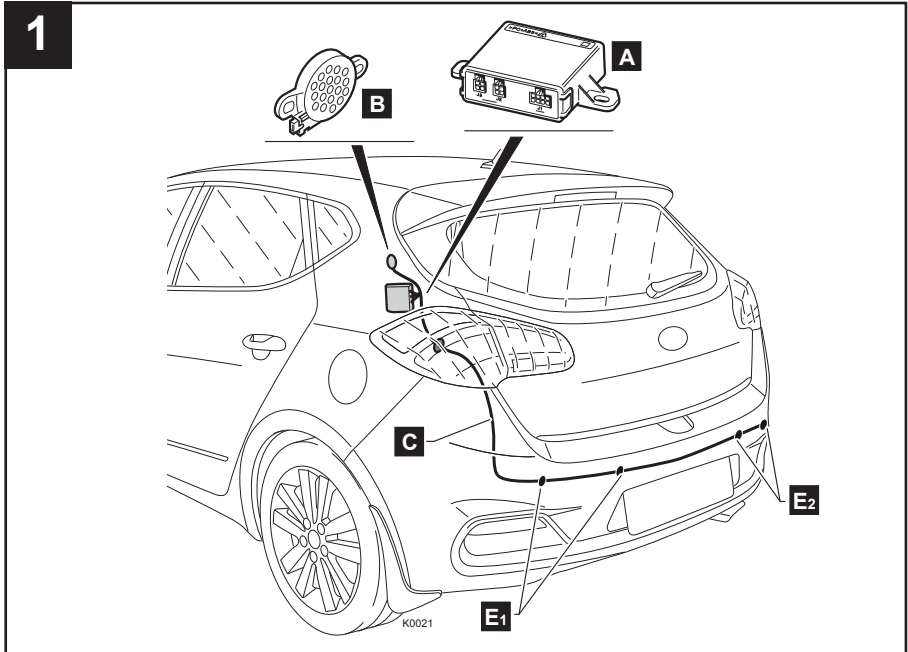

3

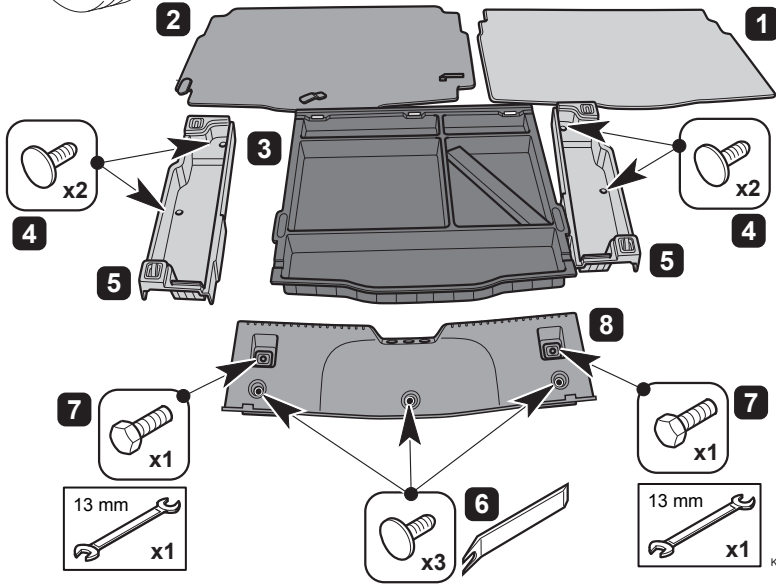
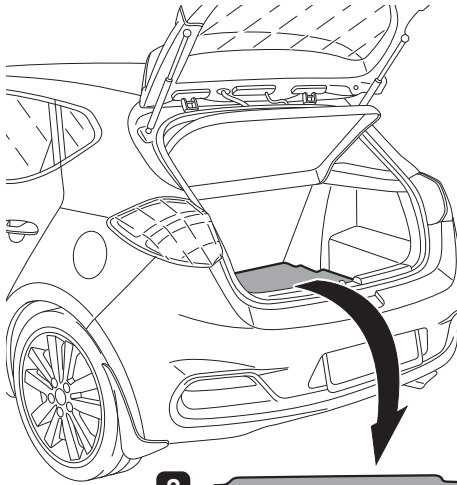

K0024

4

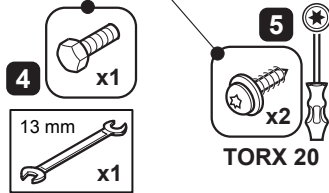
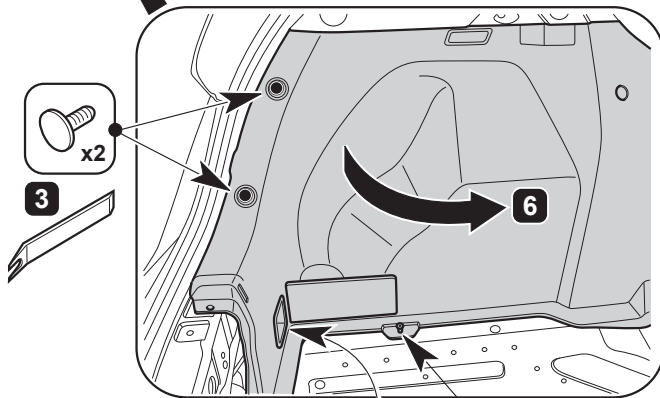
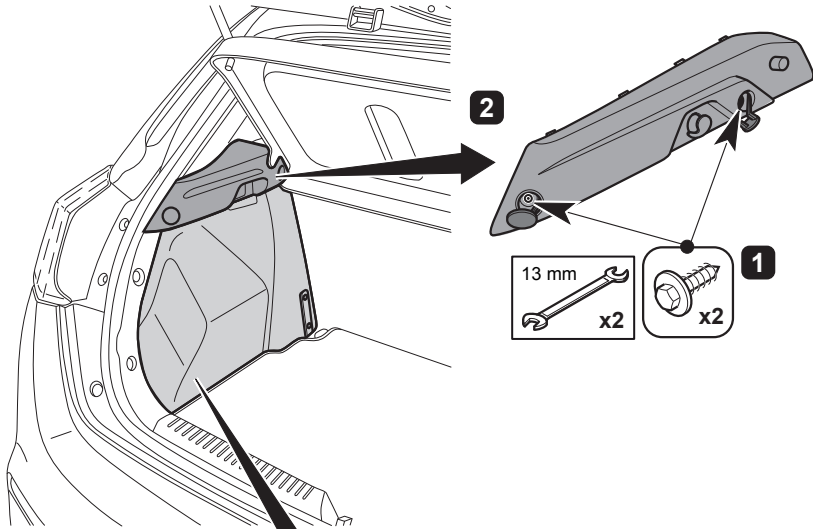

6

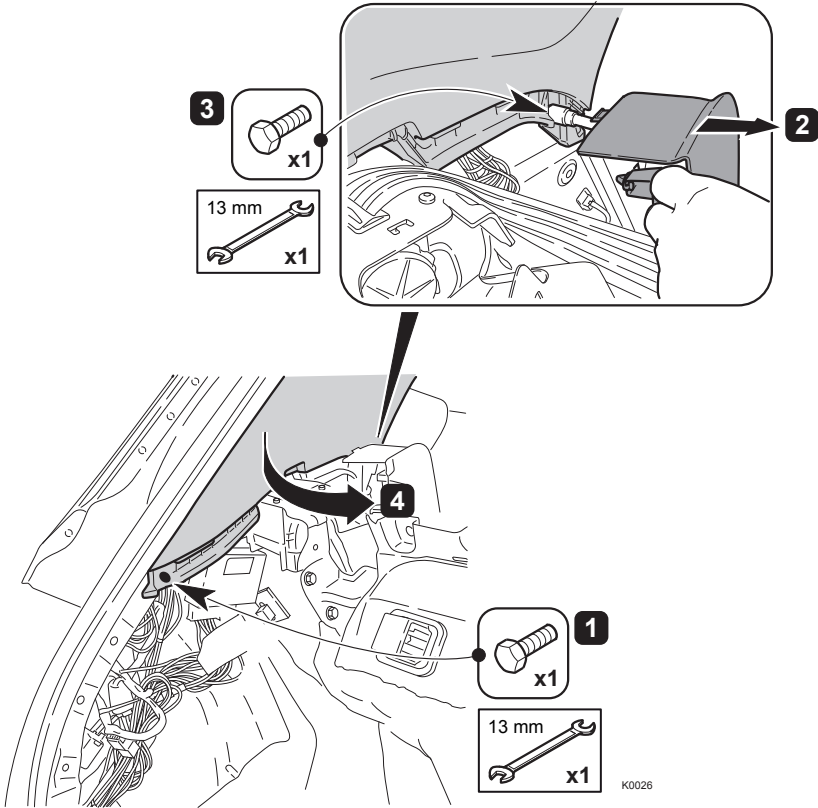

7

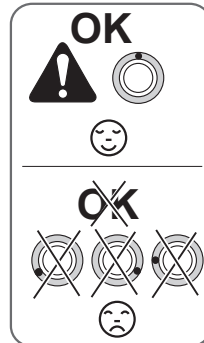
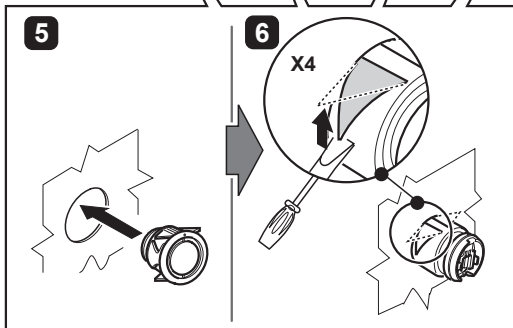
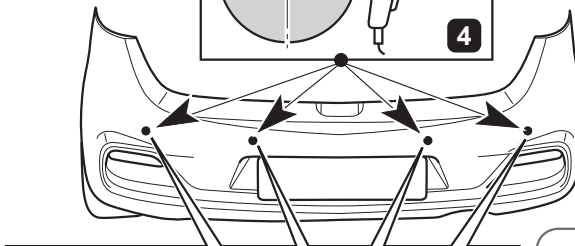
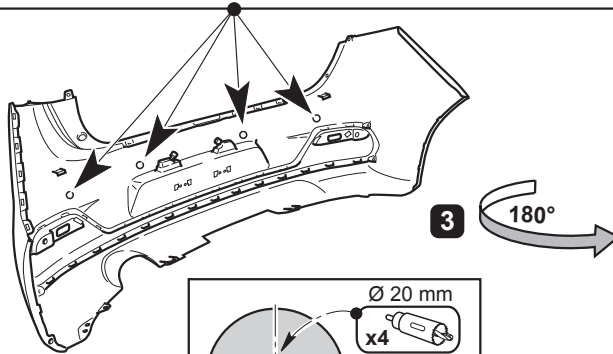
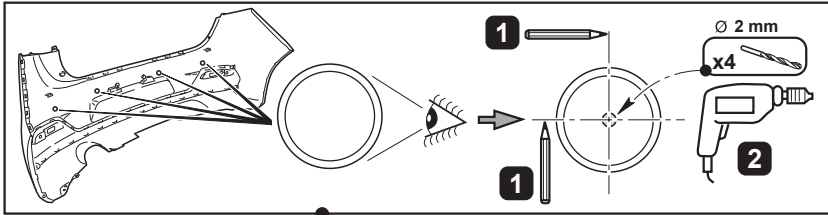

K0027

8

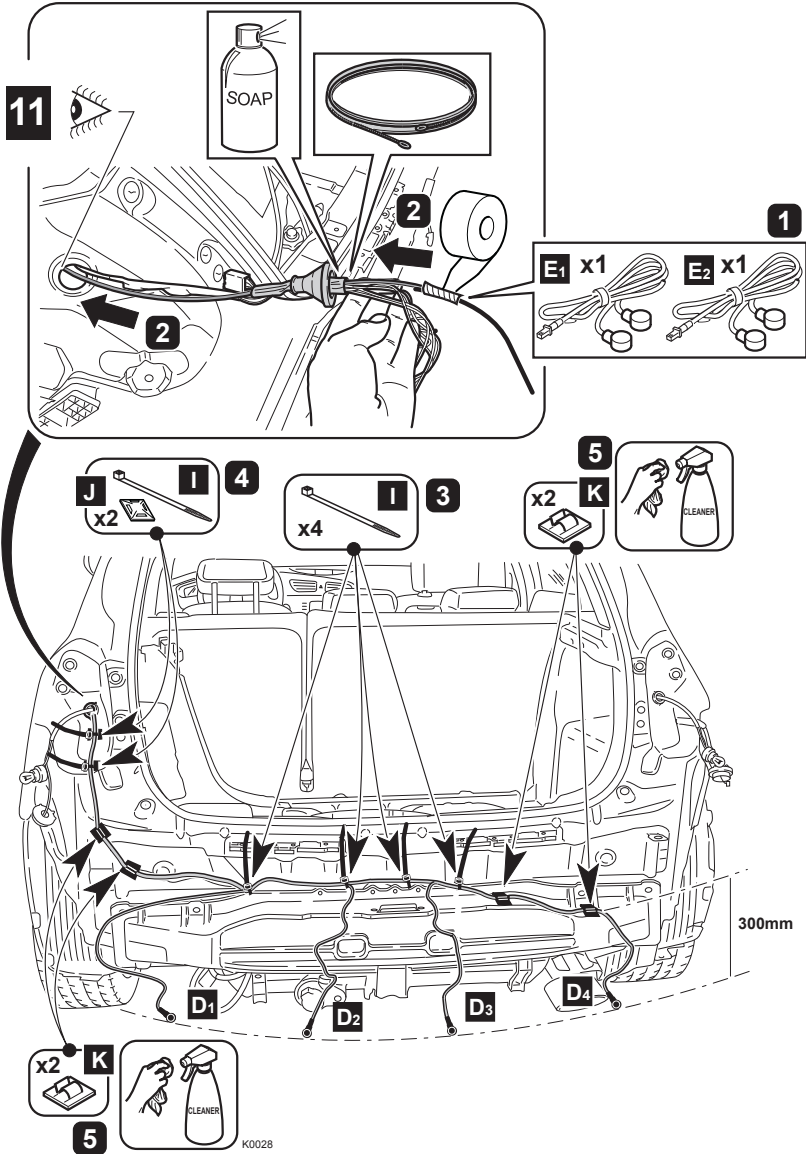

9

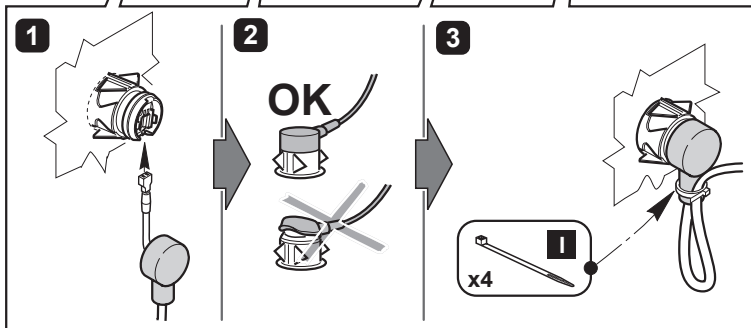
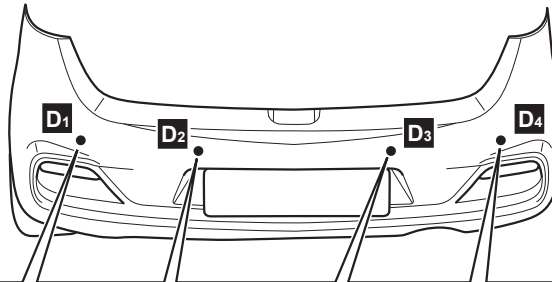

10

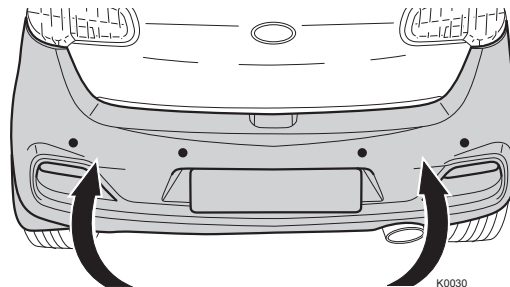

11

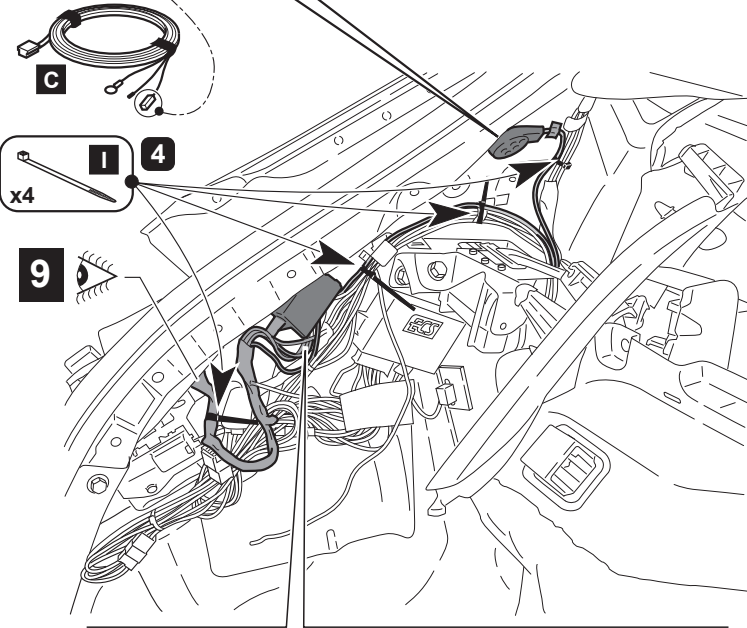
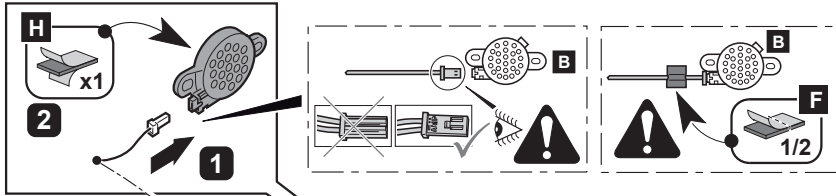

12

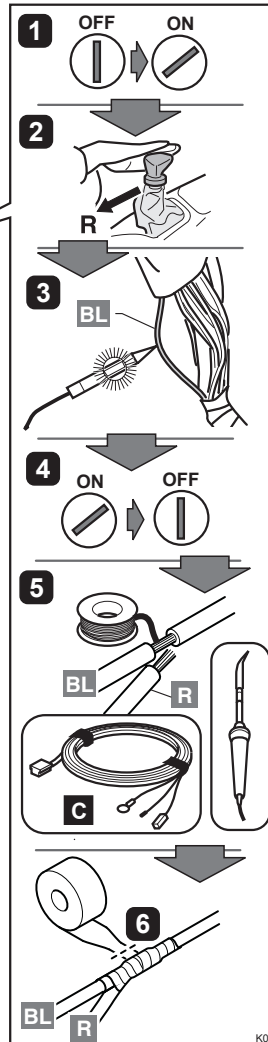
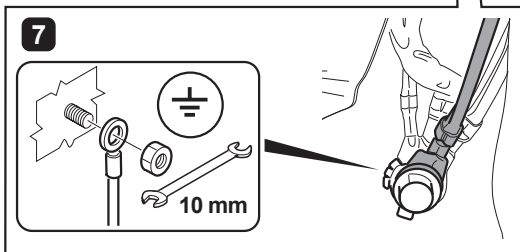
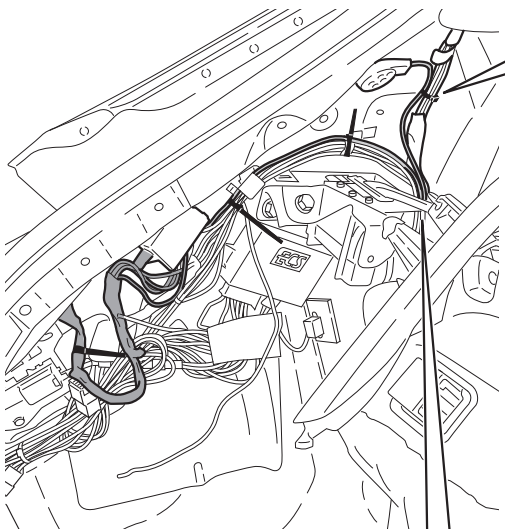

K0032

R	RED	ROT	ROUGE	ROOD	ROD	ROSSO	ROD
VERMELHO	ROJO	ROD	ČERVENÁ	PUNAINEN	CZERWONY	КРАСНЫЙ	ČERVENÝ
BL	BLUE	BLAU	BLEU	BLAUW	BLÁ	BLU	BLÁ
AZUL	AZUL	BLÁ	MODRÁ	SININEN	NIEBIESKA	СИНИЙ	MODRÁ

13

SETUP

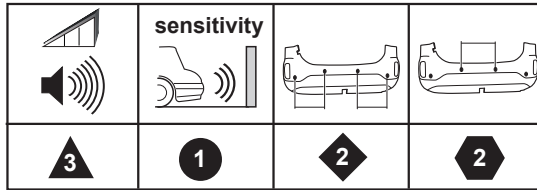

K0033

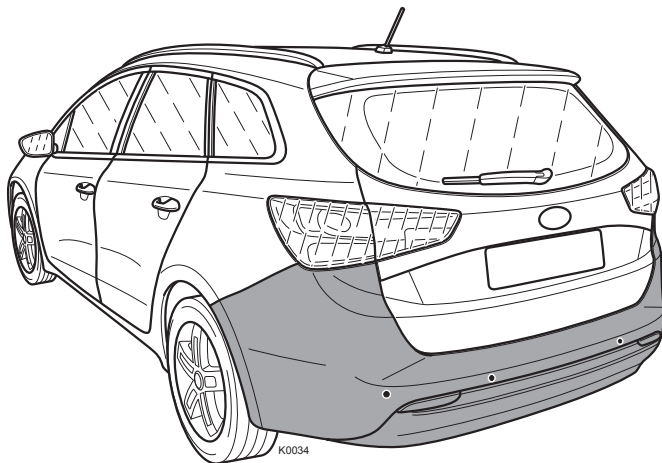

K0034

cee'd wagon 2012

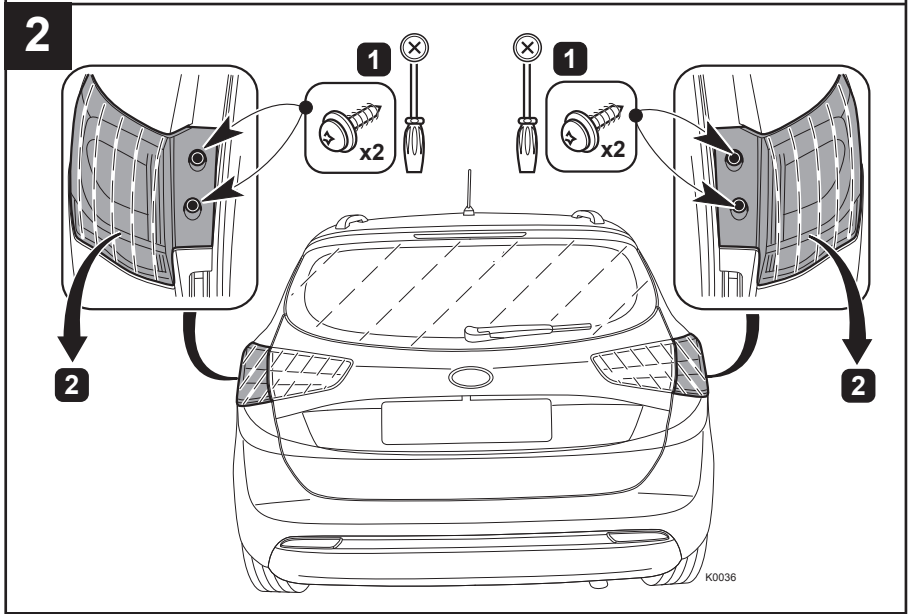
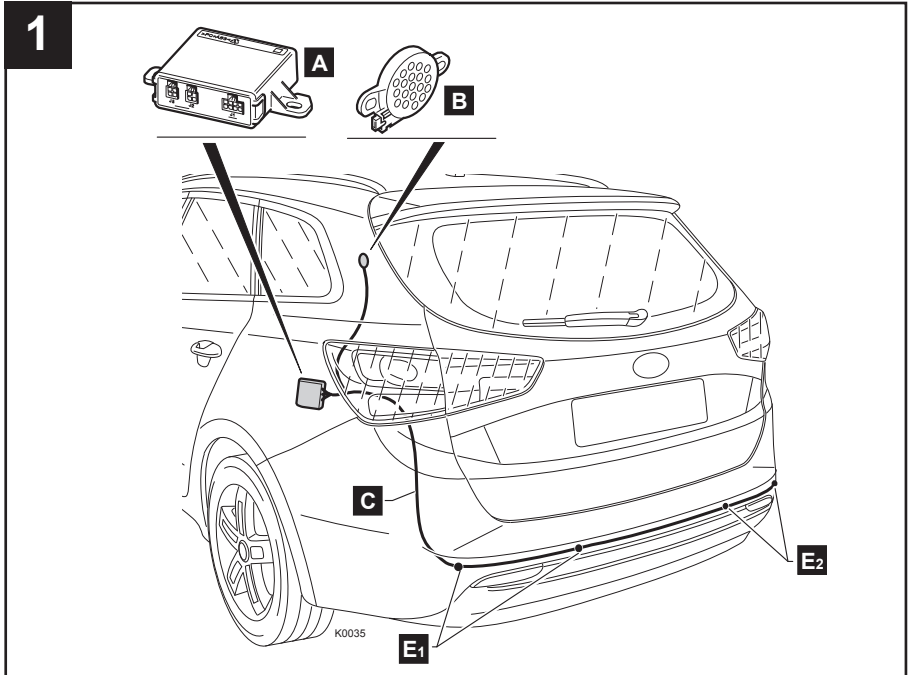

3

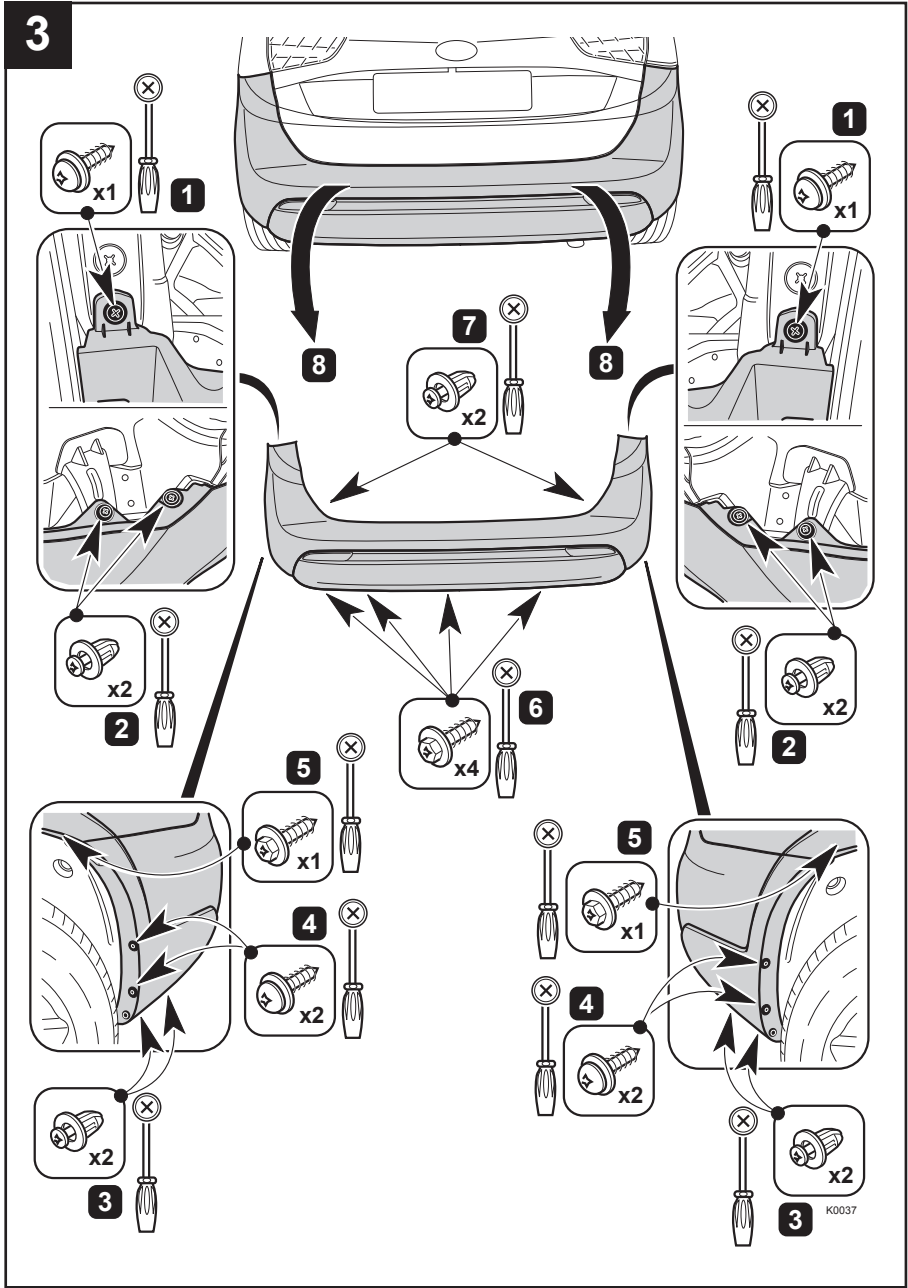

4

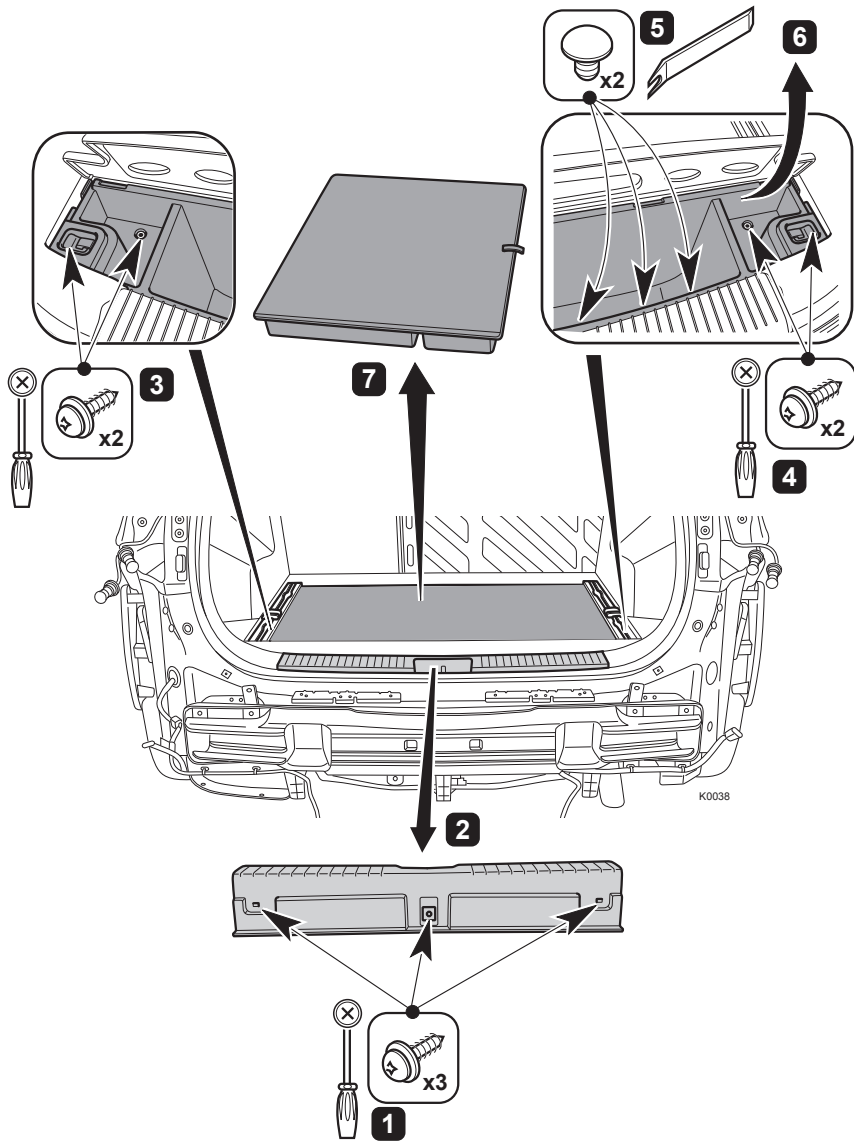

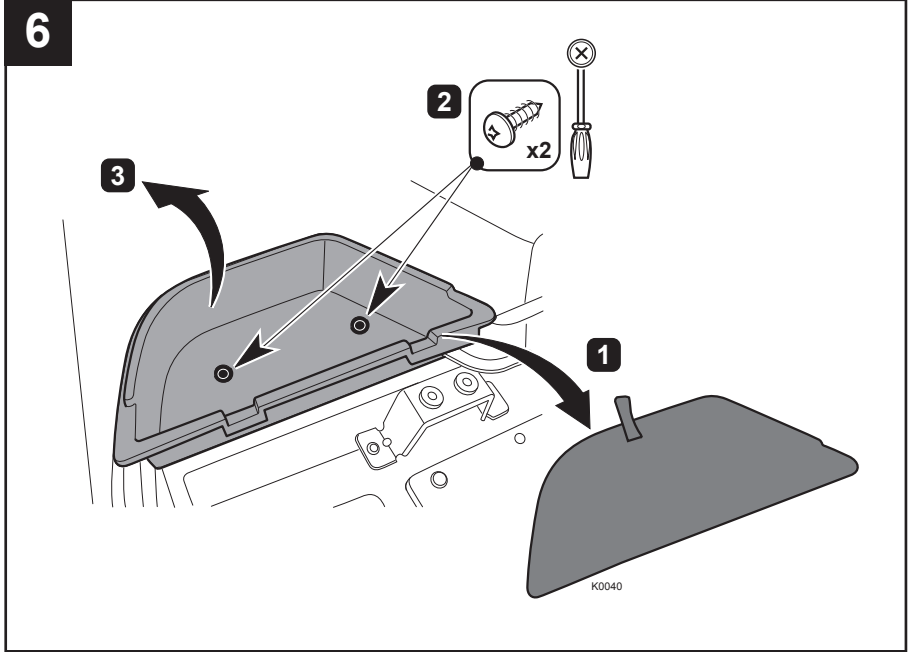
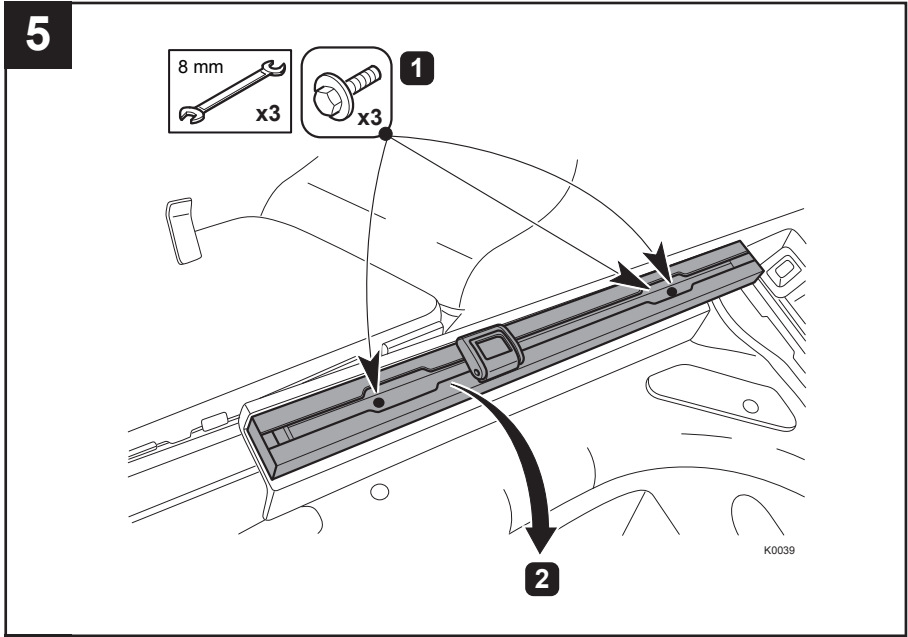

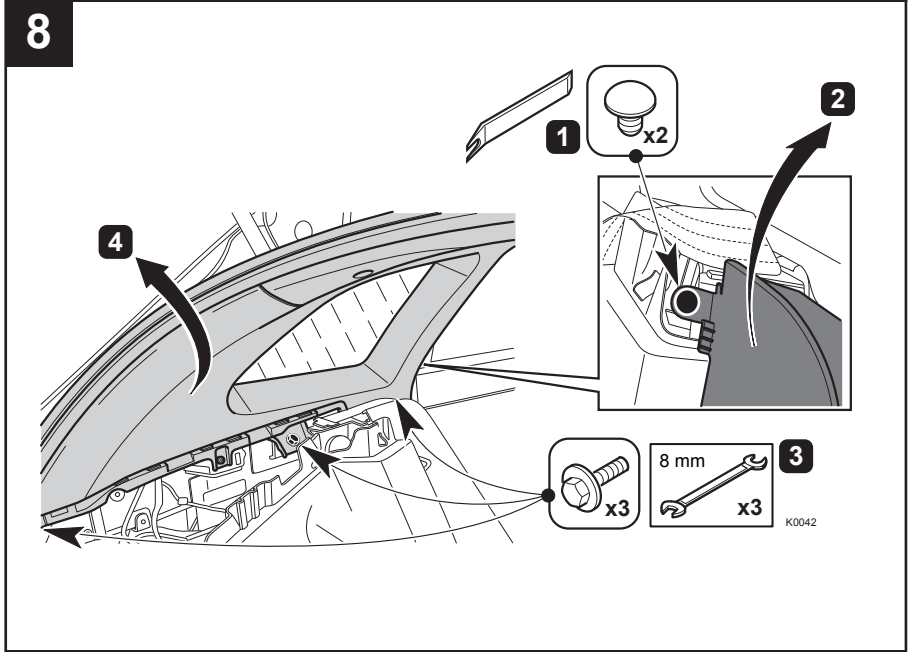
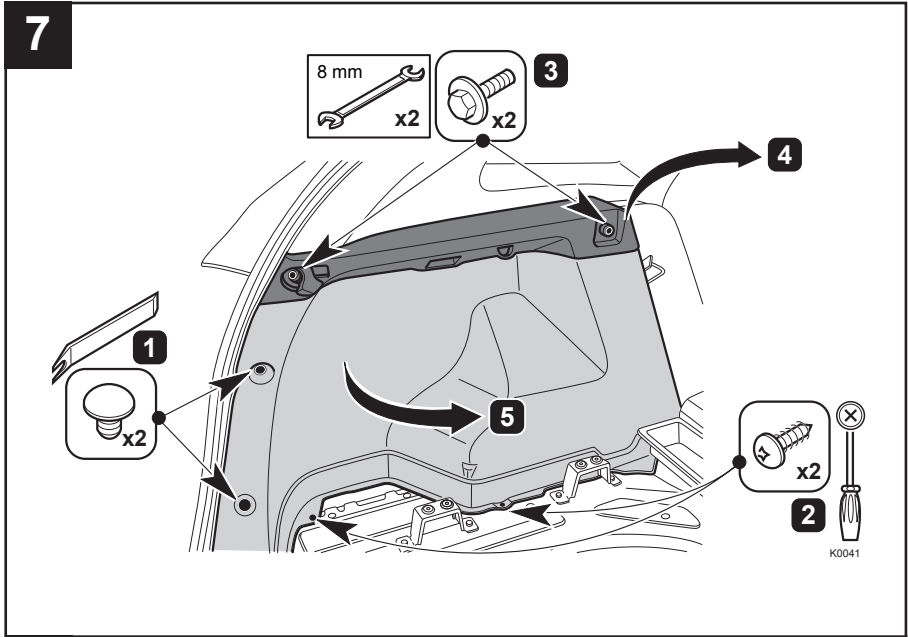

9

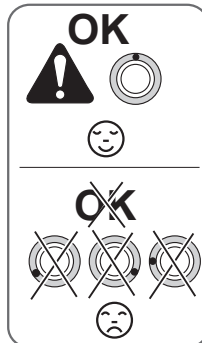
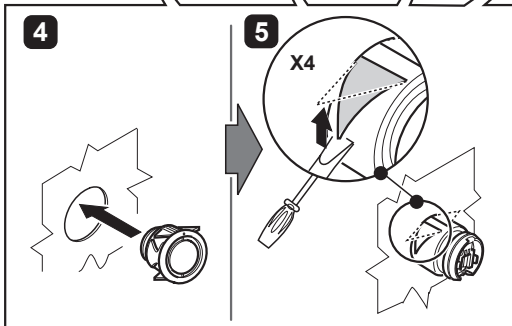
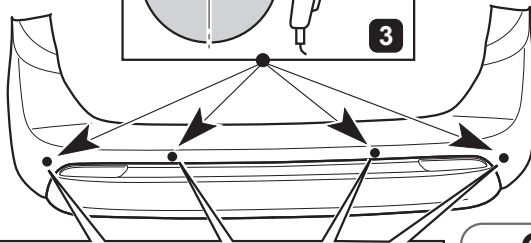
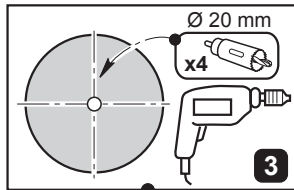
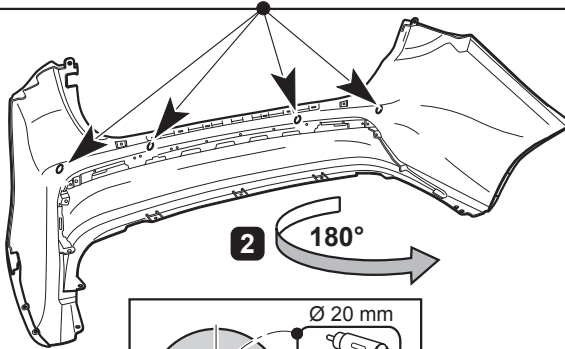
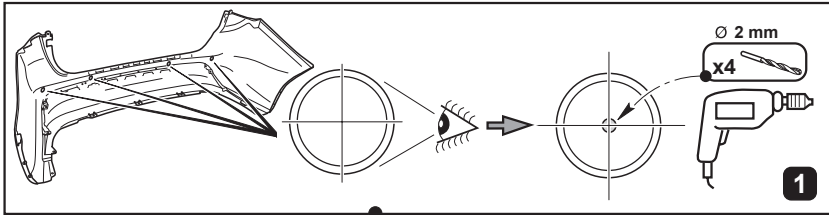

K0043

10

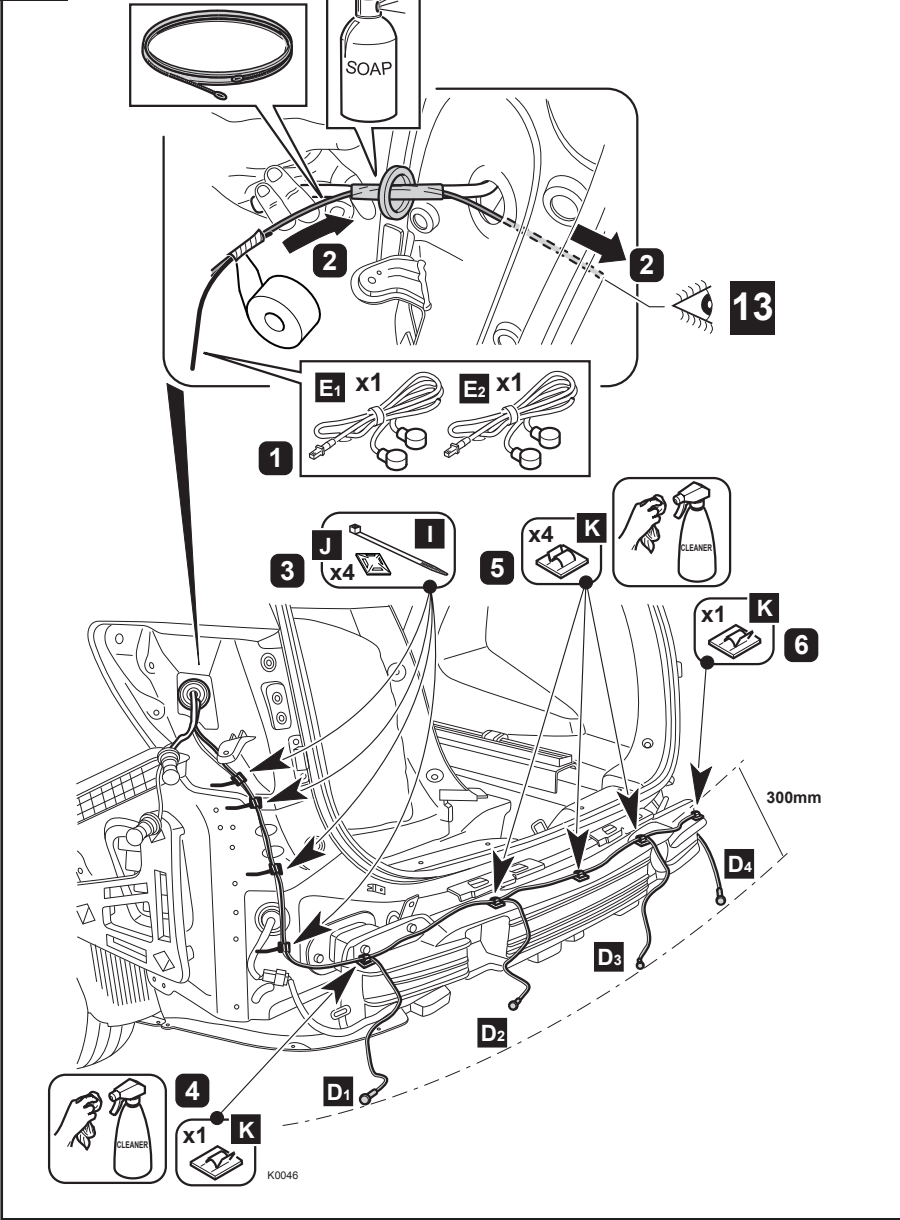

11

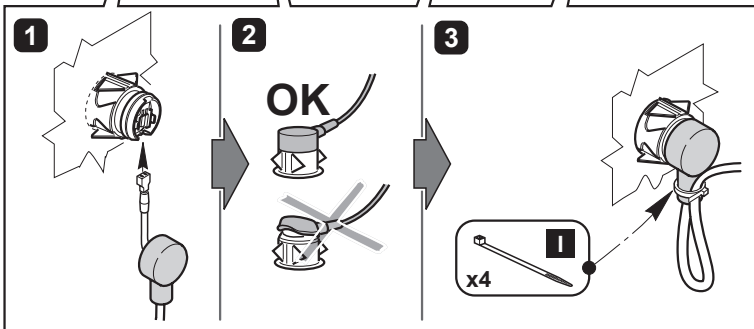
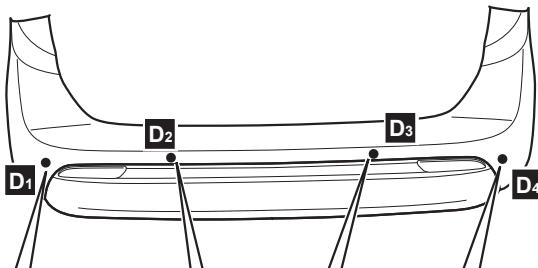

12

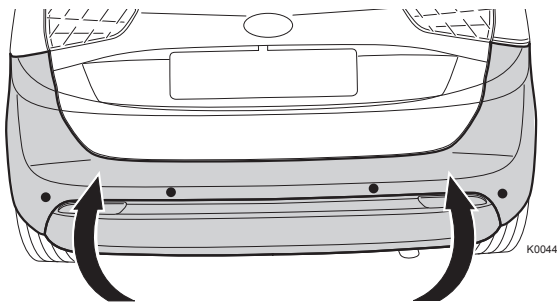

13

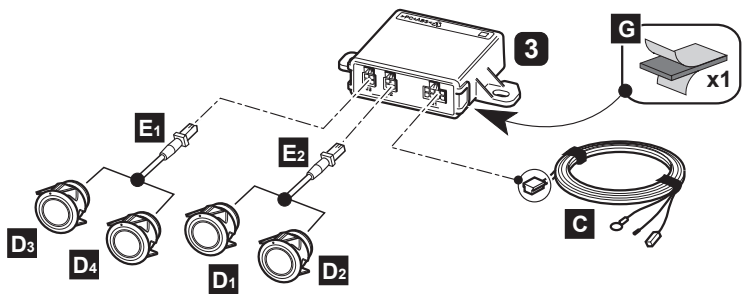
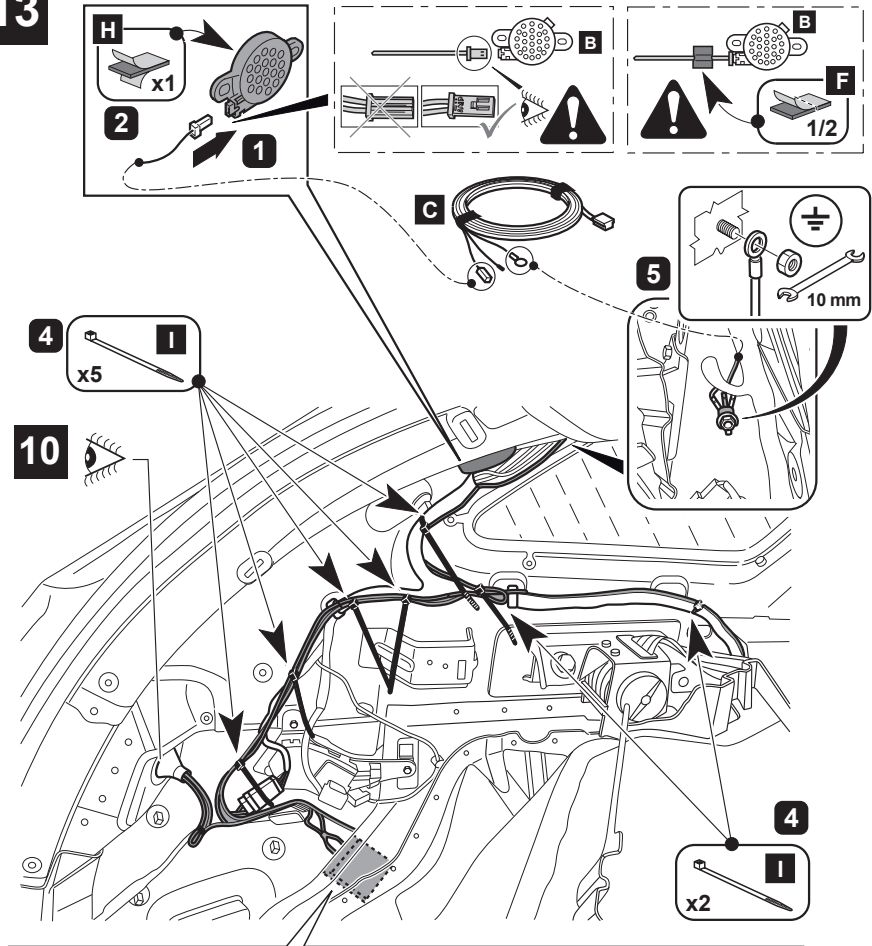

K0047

14

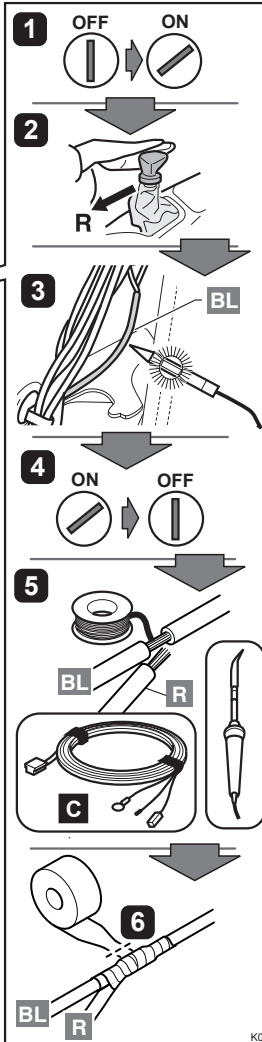
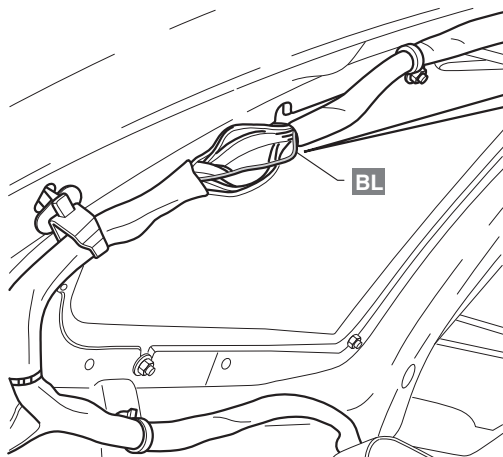

K0048

R	RED	ROT	ROUGE	ROOD	ROD	ROSSO	ROD
VERMELHO	ROJO	ROD	ČERVENÁ	PUNAINEN	CZERWONY	КРАСНЫЙ	ČERVENÝ
BL	BLUE	BLAU	BLEU	BLAUW	BLÁ	BLU	BLÁ
AZUL	AZUL	BLÁ	MODRÁ	SININEN	NIEBIESKA	СИНИЙ	MODRÁ

15

SETUP

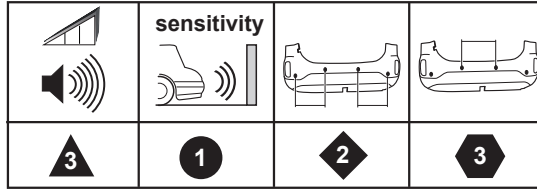

K0049

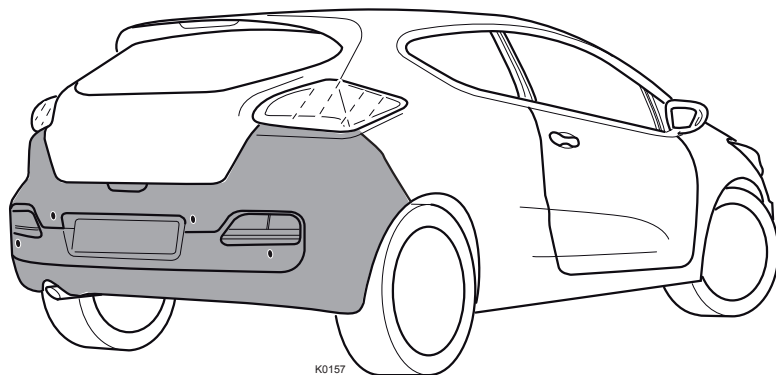

K0157

**pro_ cee'd +
cee'd GT 3dr 2013**

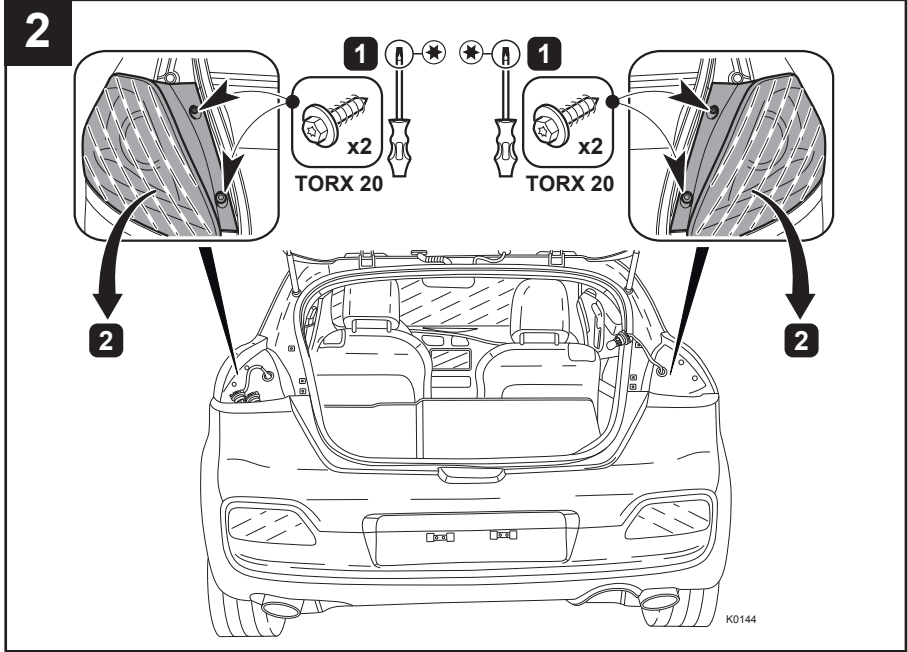
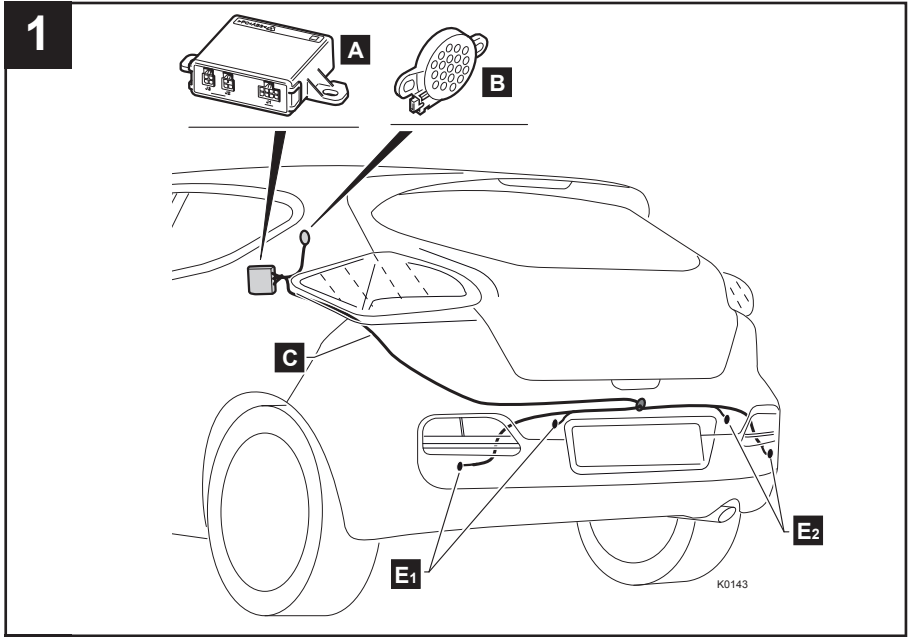

3

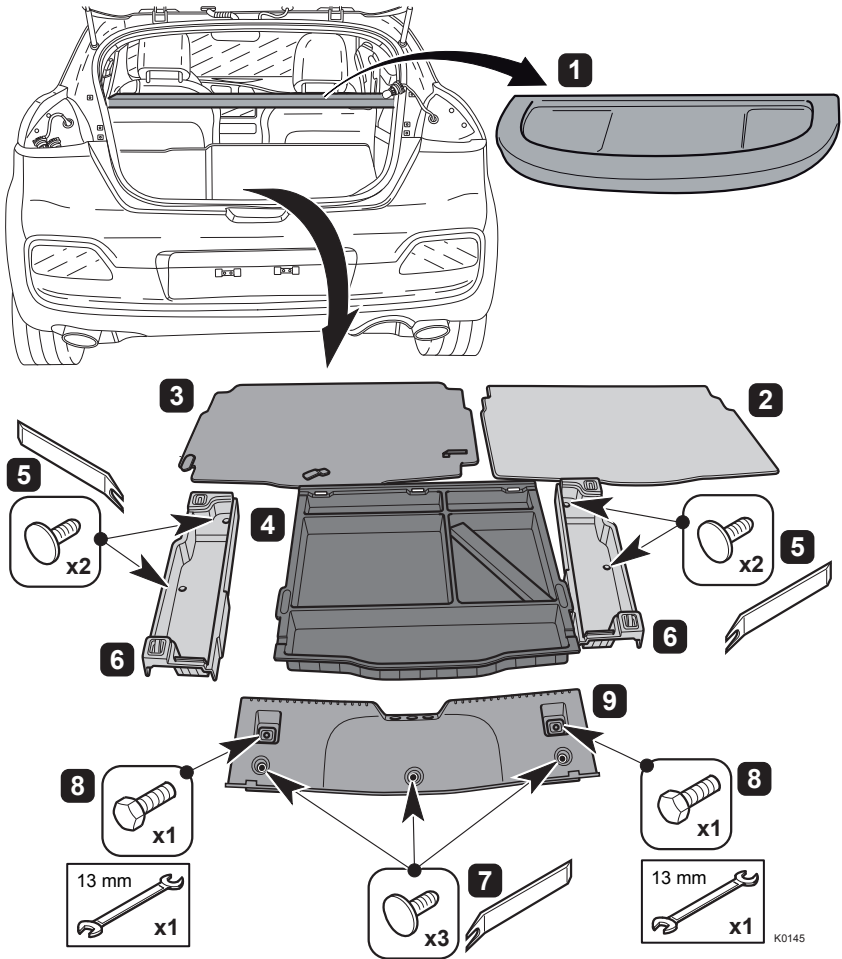

4

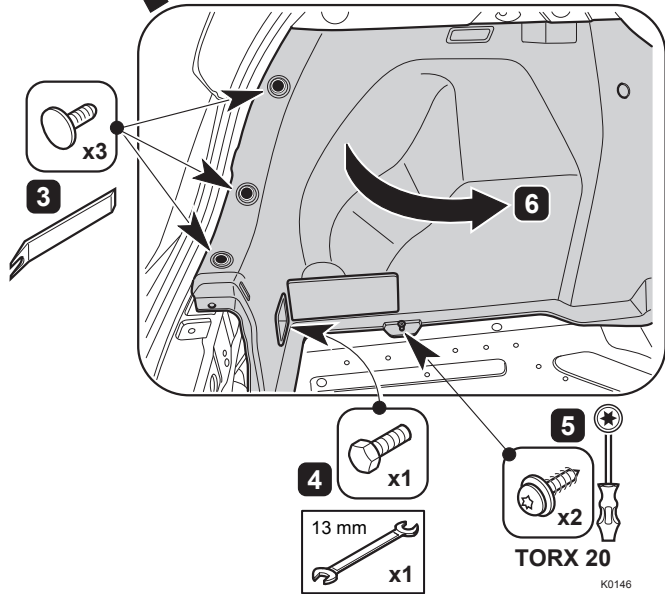
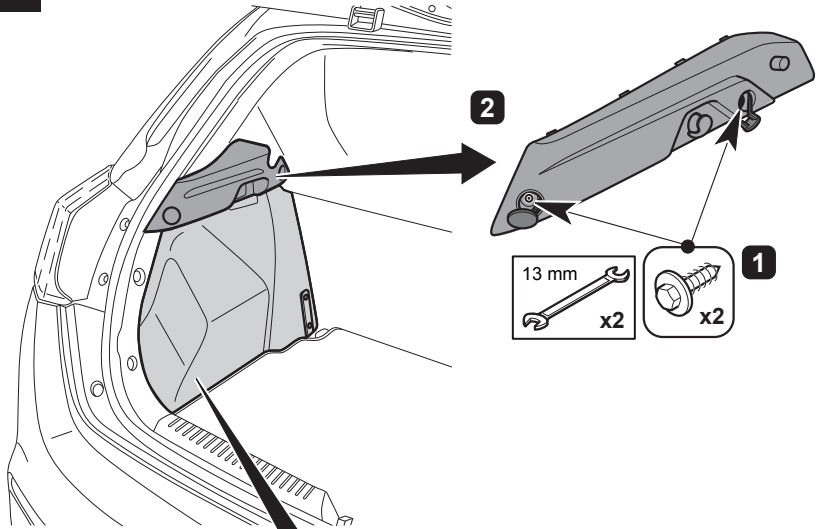

5

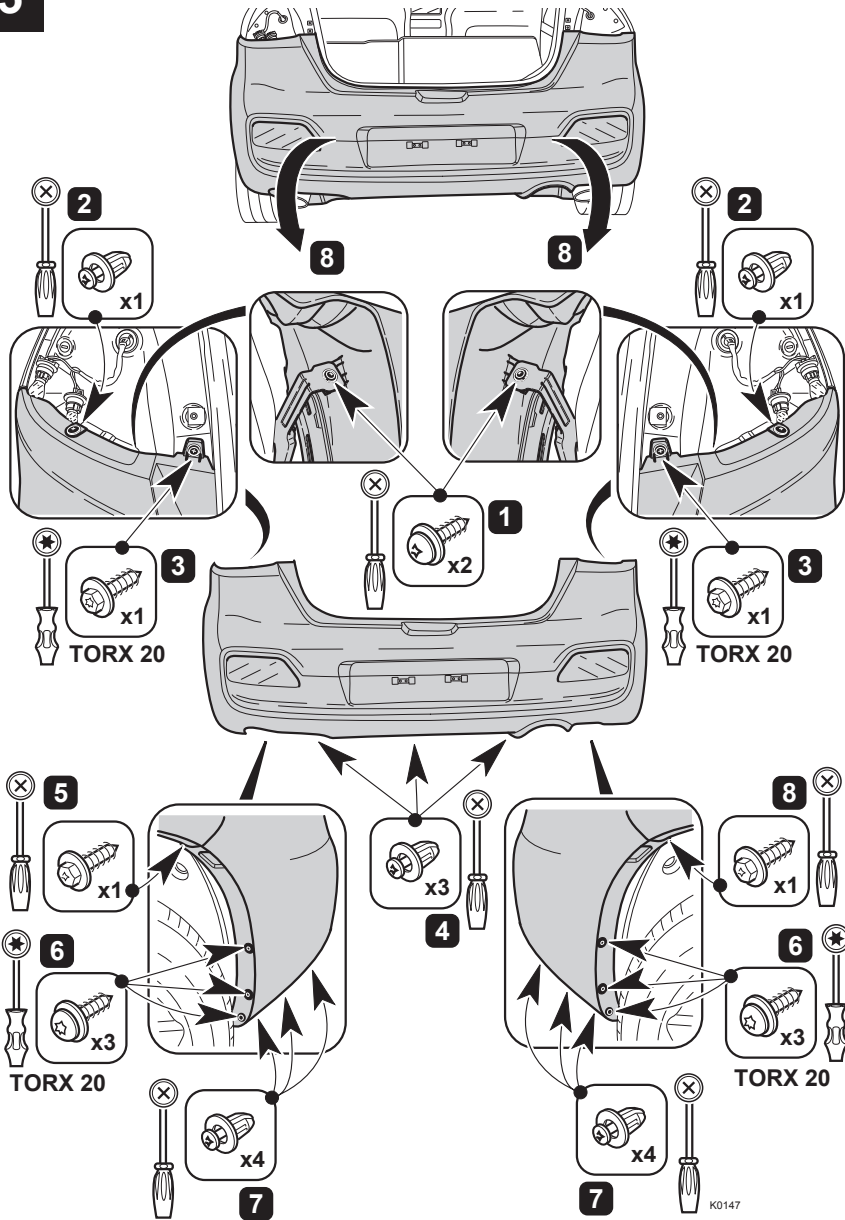

6

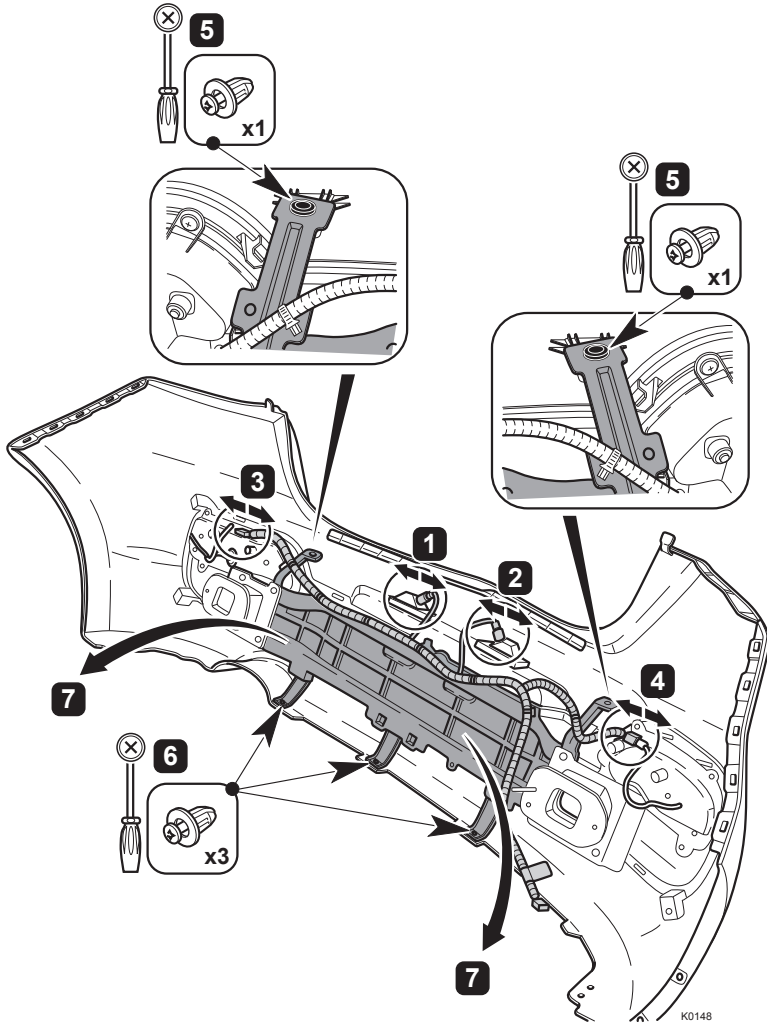

7

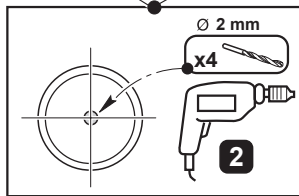
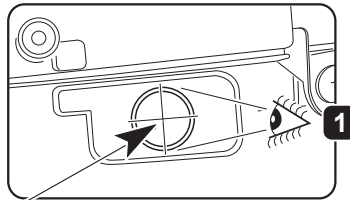
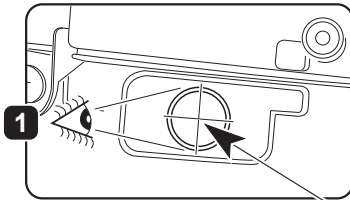
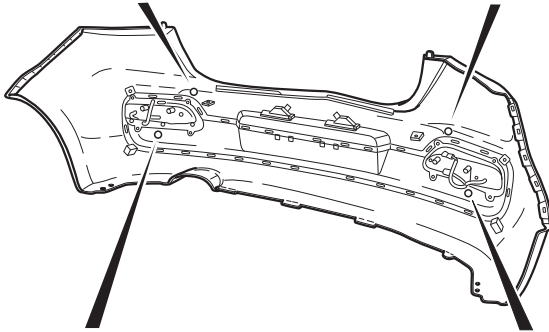
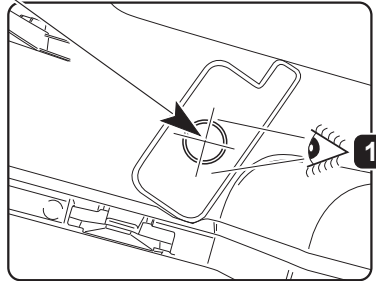
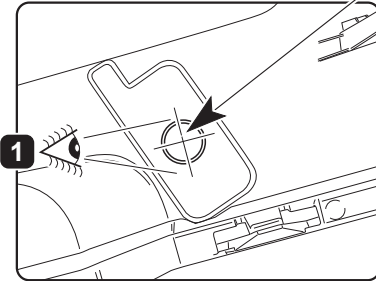
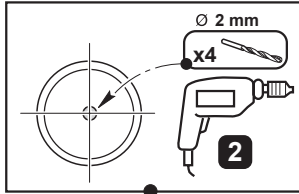

K0149

8

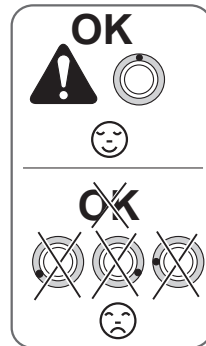
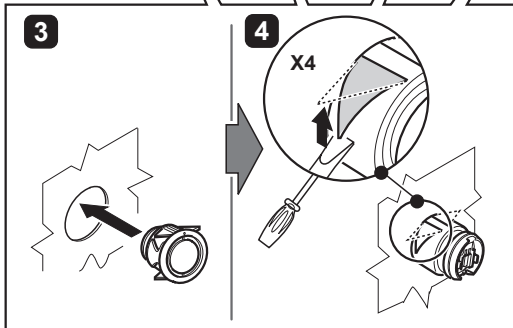
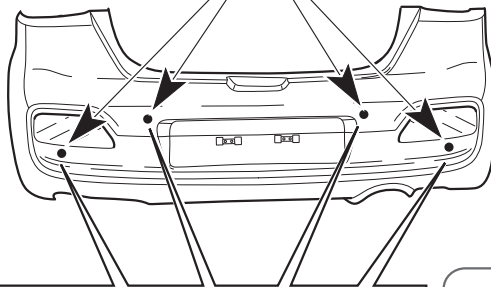
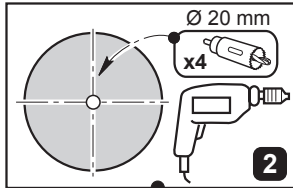

K0150

9

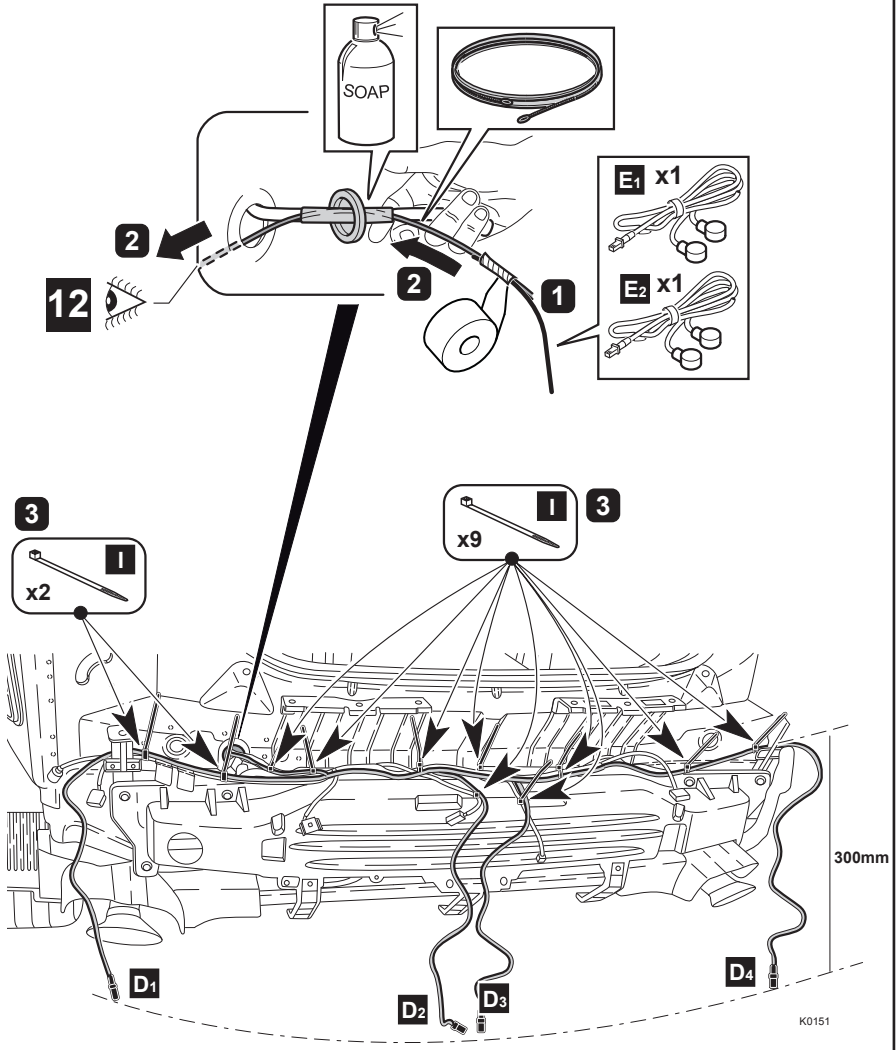

10

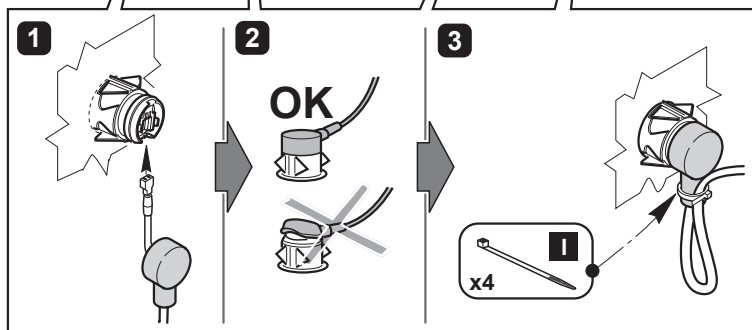
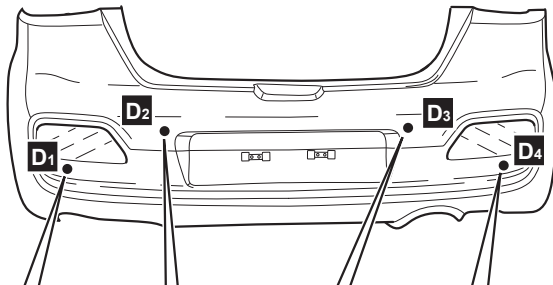

K0152

11

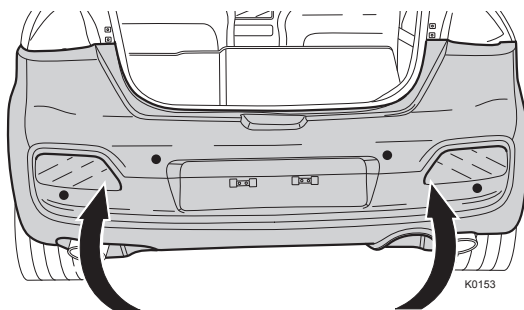

K0153

12

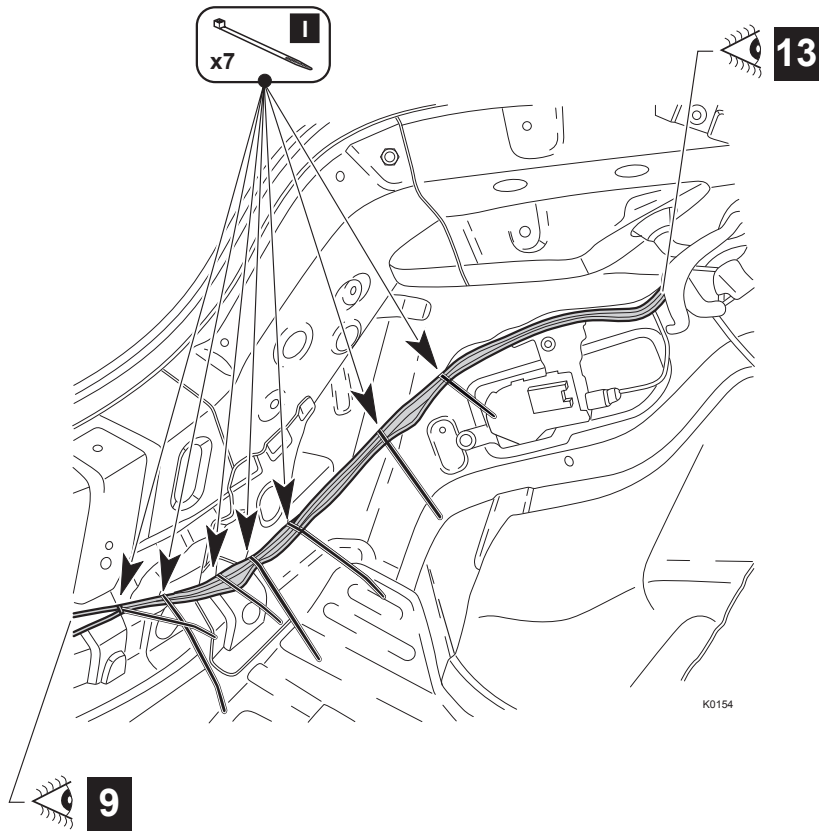

K0154

14

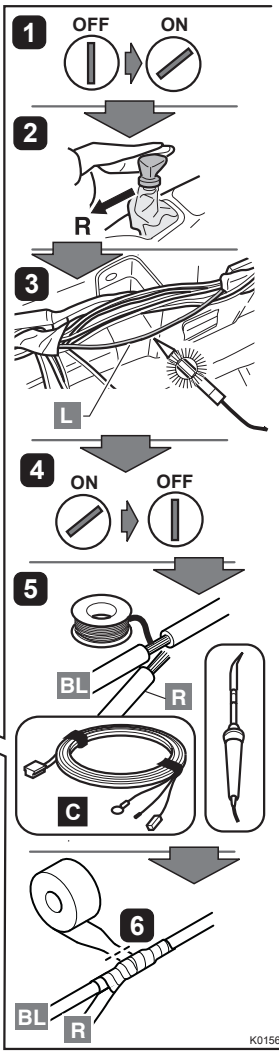
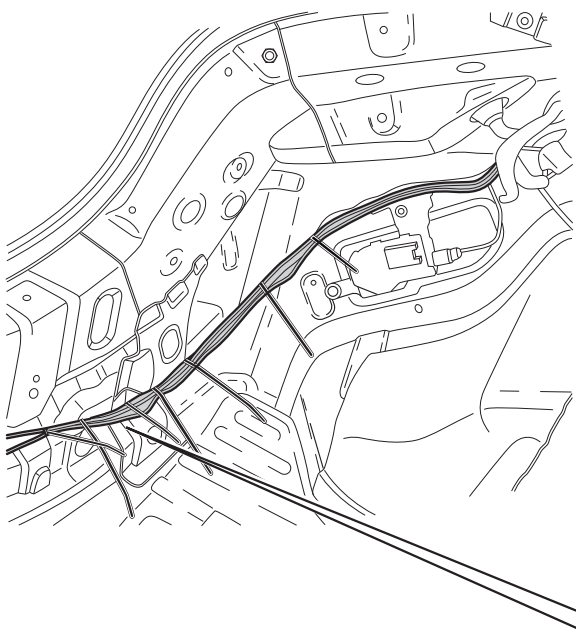

R	RED	ROT	ROUGE	ROOD	ROD	ROSSO	ROD
VERMELHO	ROJO	ROD	ČERVENÁ	PUNAINEN	CZERWONY	КРАСНЫЙ	ČERVENÝ

L	LIGHT BLUE	HELLBLAU	AZUR	LICHTBLAUW	HIMMELBLÄ	AZZURRO	LYSEBLÄ
AZUL-CLARO	CELESTE	LJUSBLÄ	MODRA	VAALEANSININEN	LAZUROWY	СИНИЙ	SVETLOMODRÁ

15

SETUP

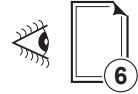
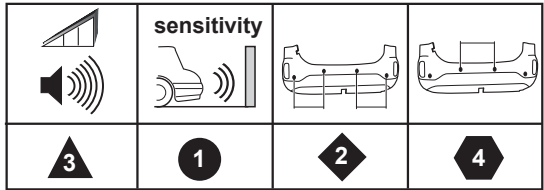

K0158

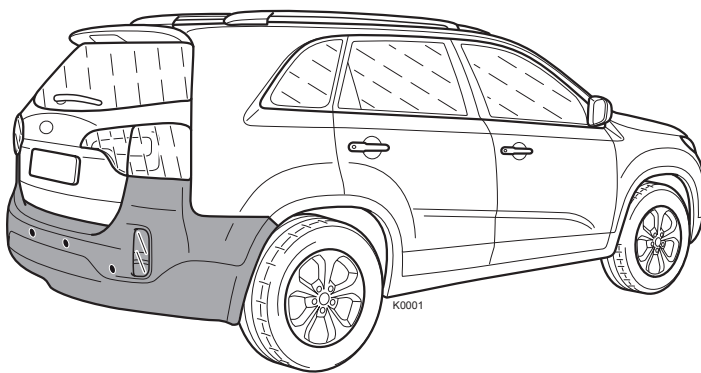

SORENTO 2012

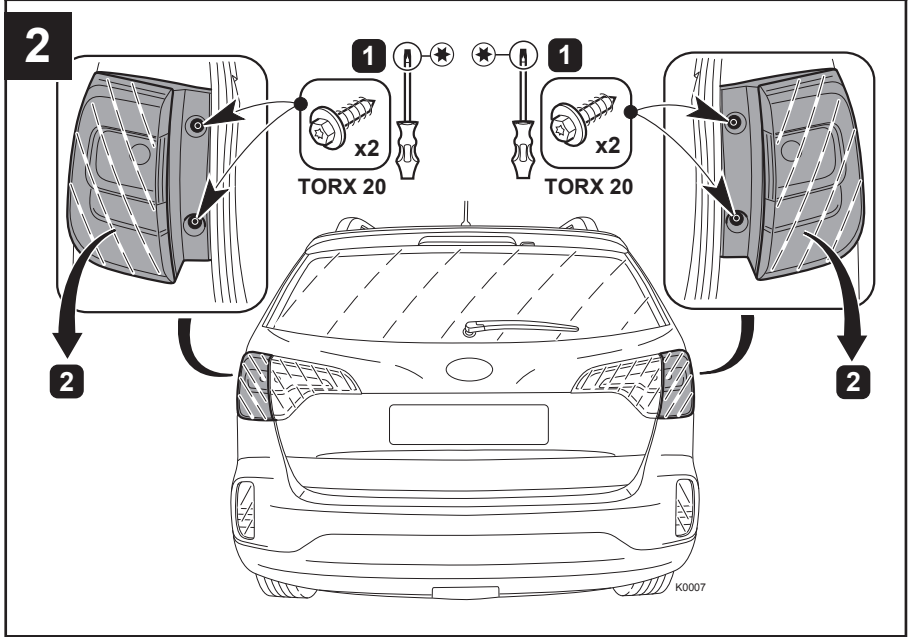
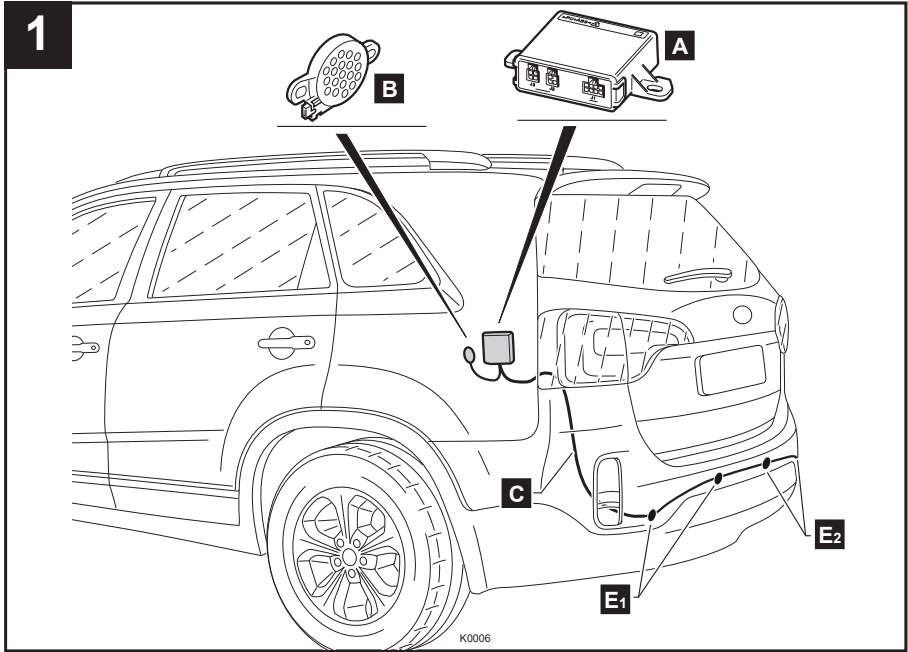

3

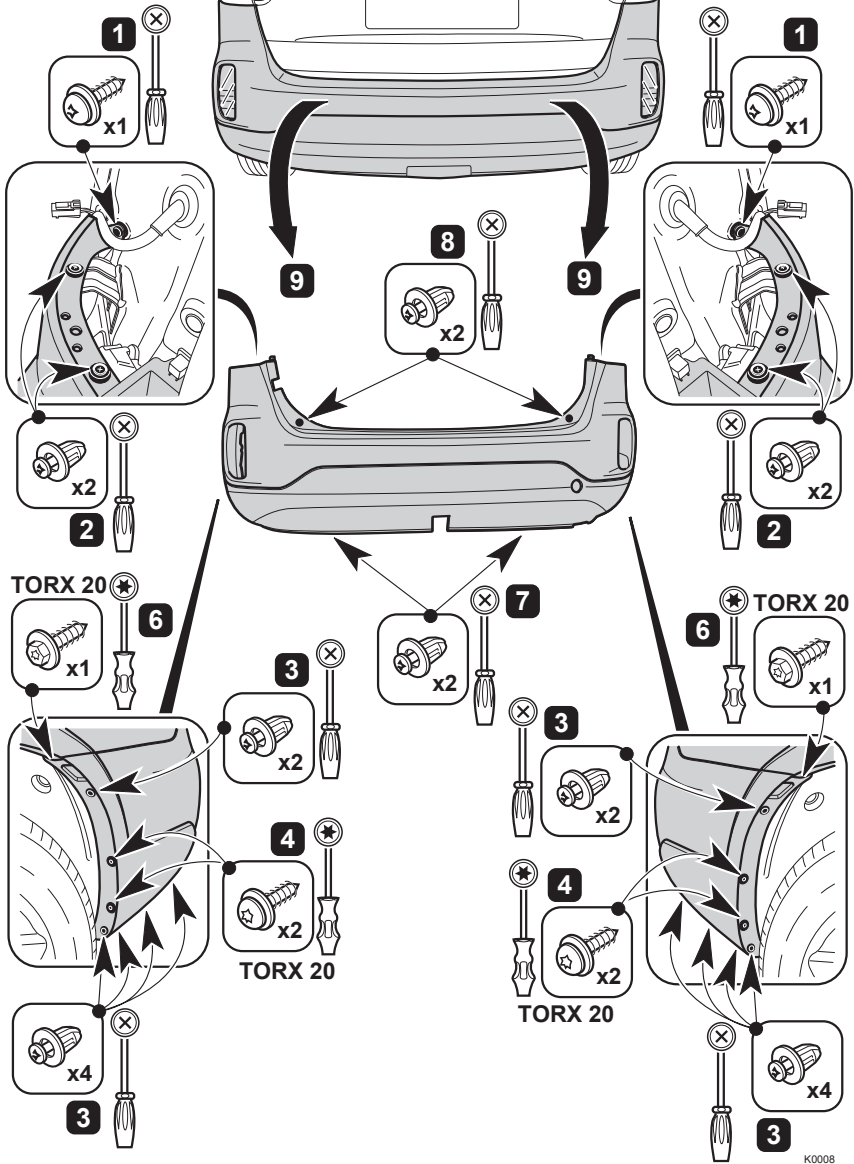

4

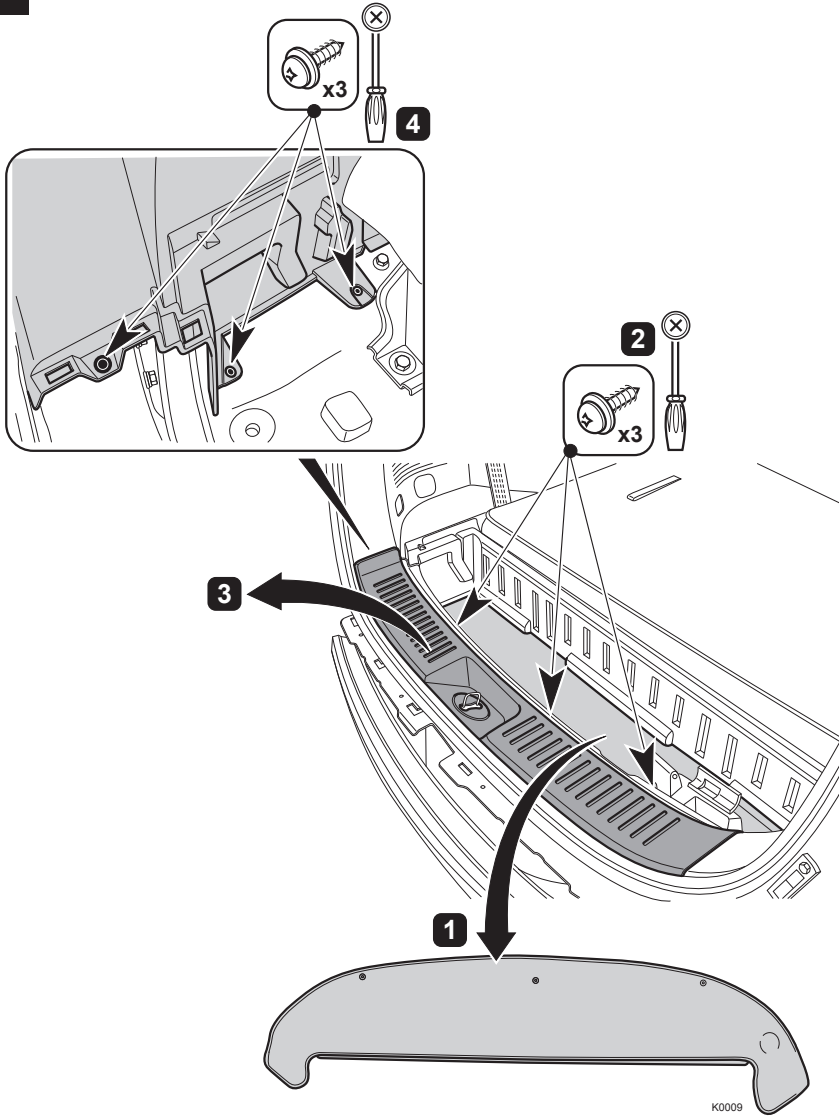

5

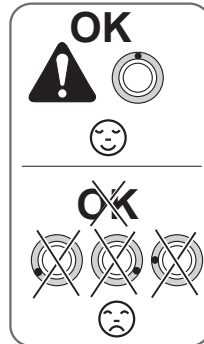
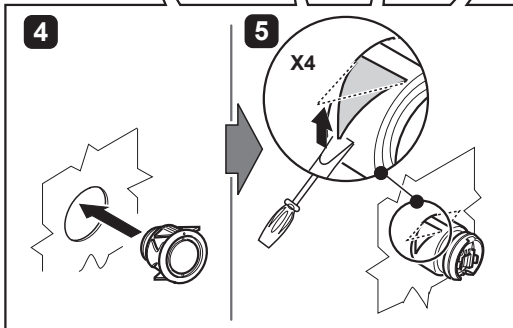
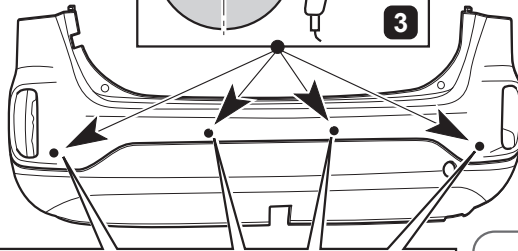
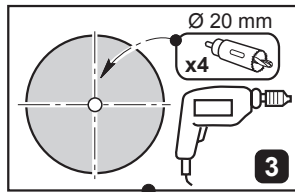
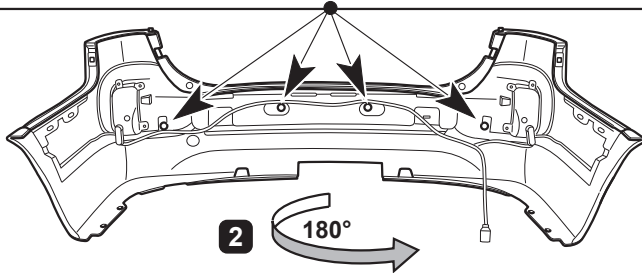
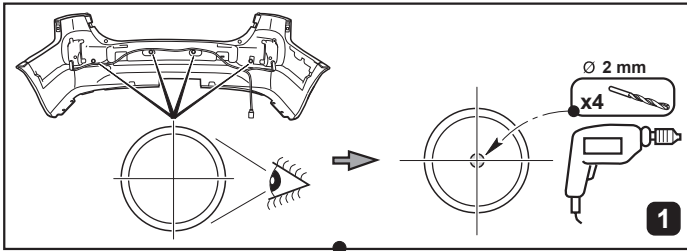

6

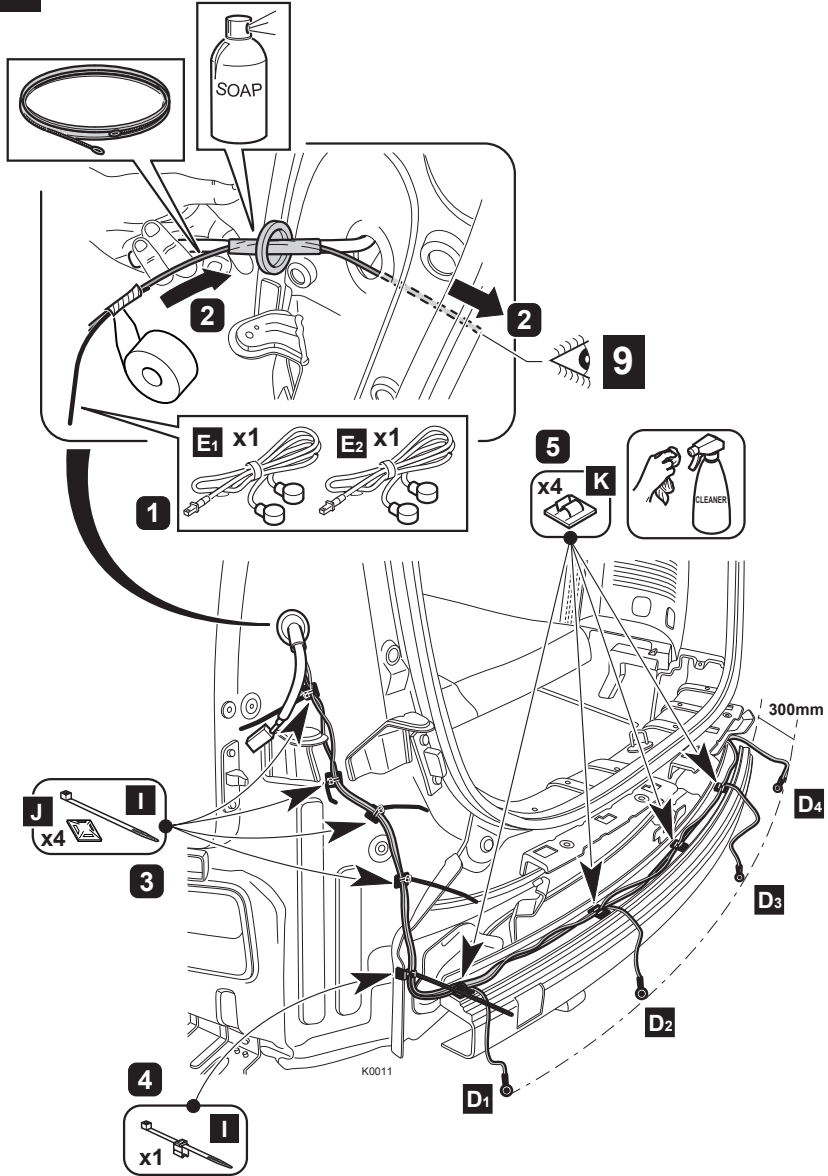

7

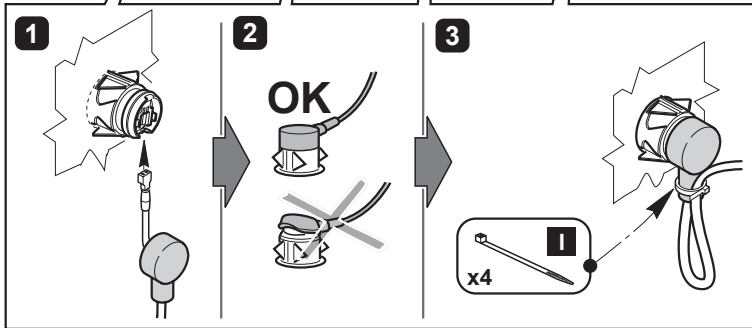
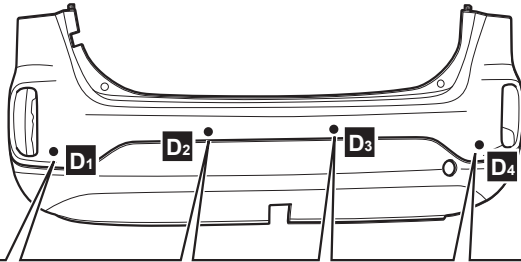

8

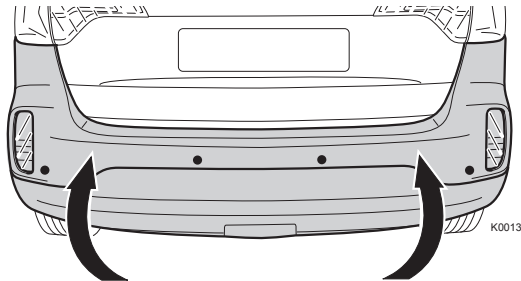

10

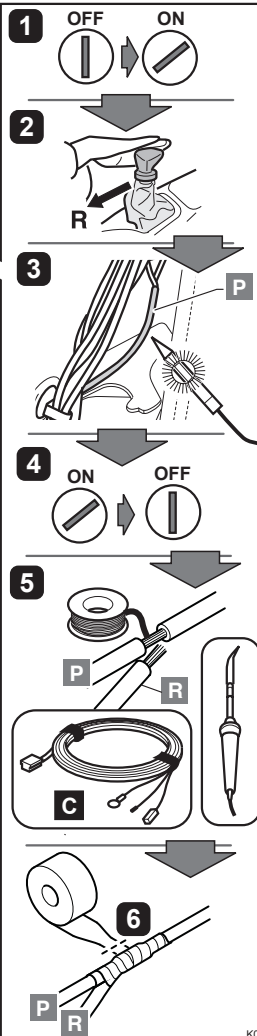
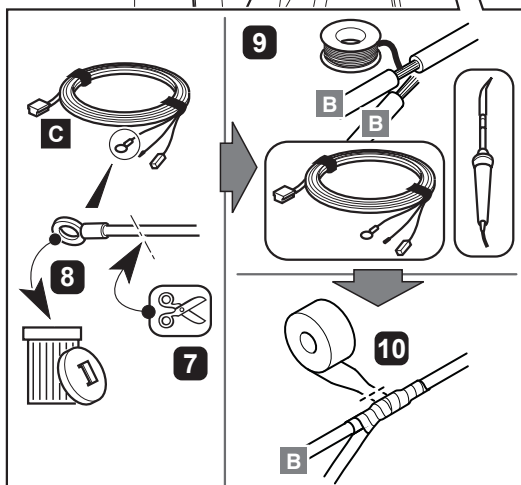
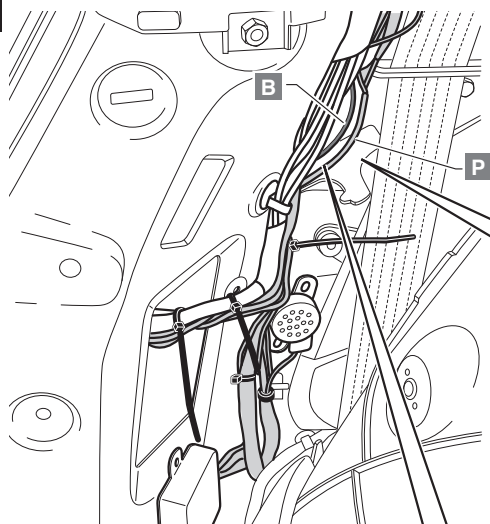

K0015

P	PINK	ROSA	ROSE	ROZE	LYSERØD	ROSA	ROSA
ROSA	ROSA	ROSA	RŮŽOVÝ	VAALENPUNAINEN	RÓŽOVÝ	РОЗОБИЙ	ROZA
B	BLACK	SCHWARZ	NOIR	ZWART	SORT	NERO	SVART
PRETO	NEGRO	SVART	ČERNÁ	MUSTA	CZARNY	ЧЕРНЫЙ	ČIERNY
R	RED	ROT	ROUGE	ROOD	ROD	ROSSO	ROD
VERMELHO	ROJO	ROD	ČERVENÁ	PUNAINEN	CZERWONY	КРАСНЫЙ	ČERVENÝ

SETUP

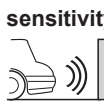
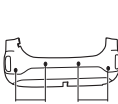
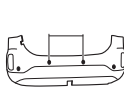
	sensitivity 		
3	1	3	2



K0018

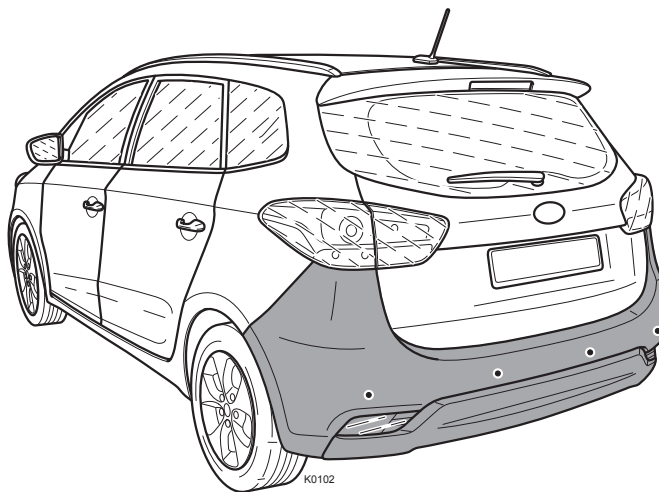

K0102

CARENS 2013

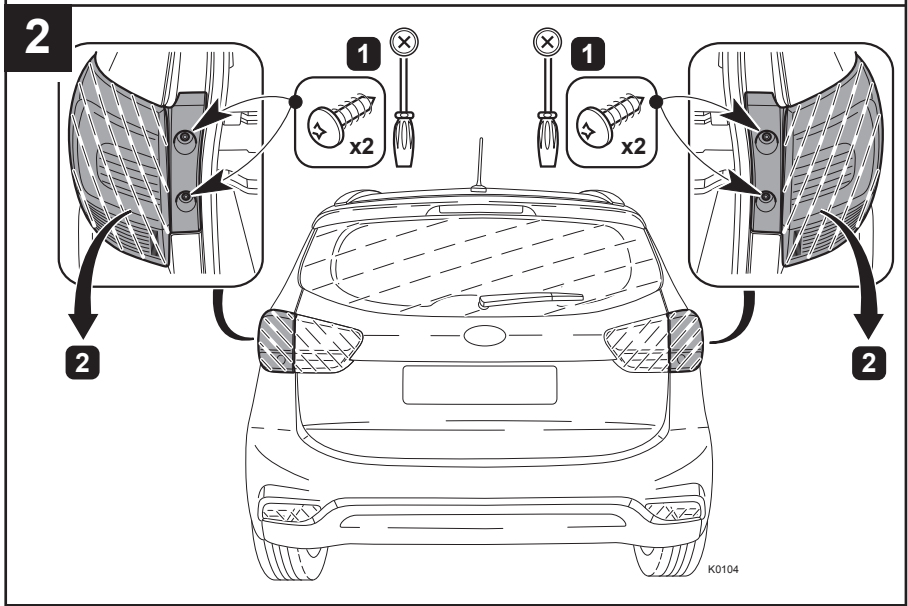
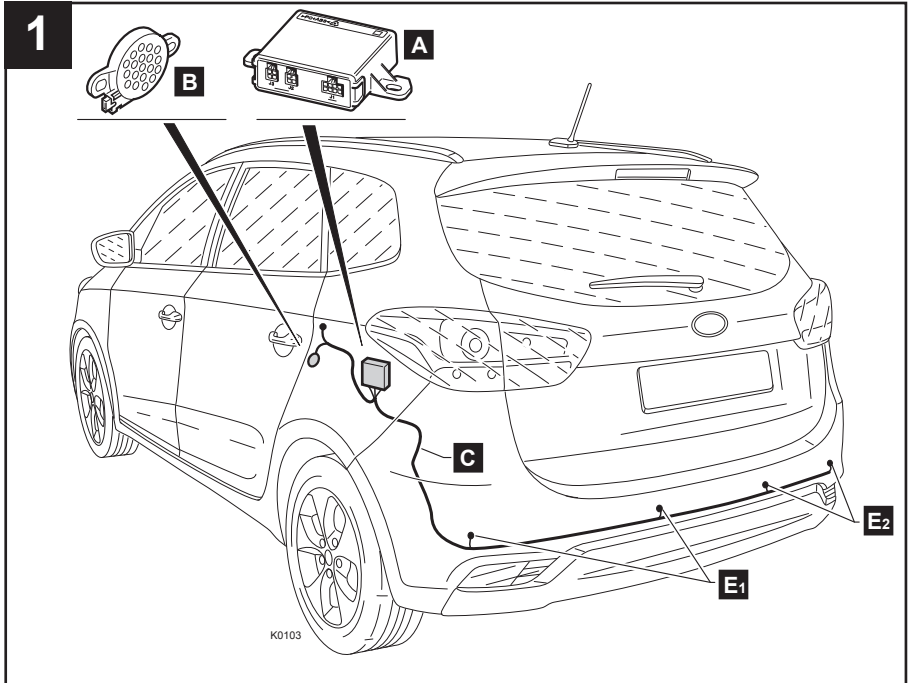

3

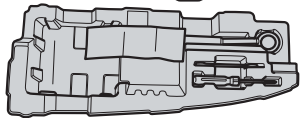
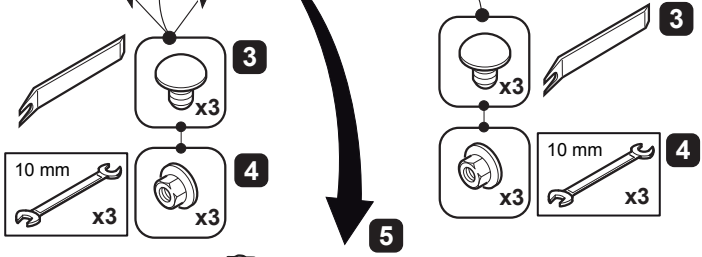
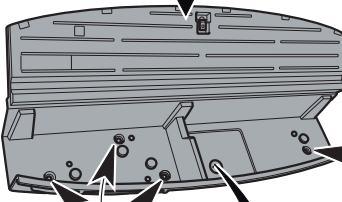
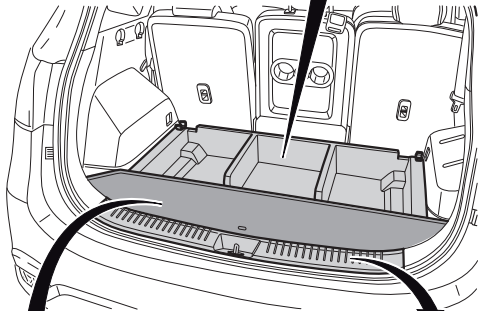
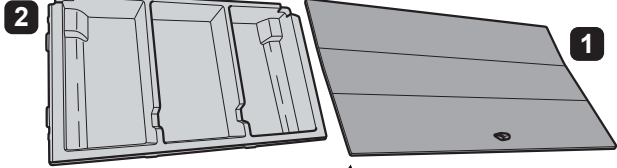

K0105

4

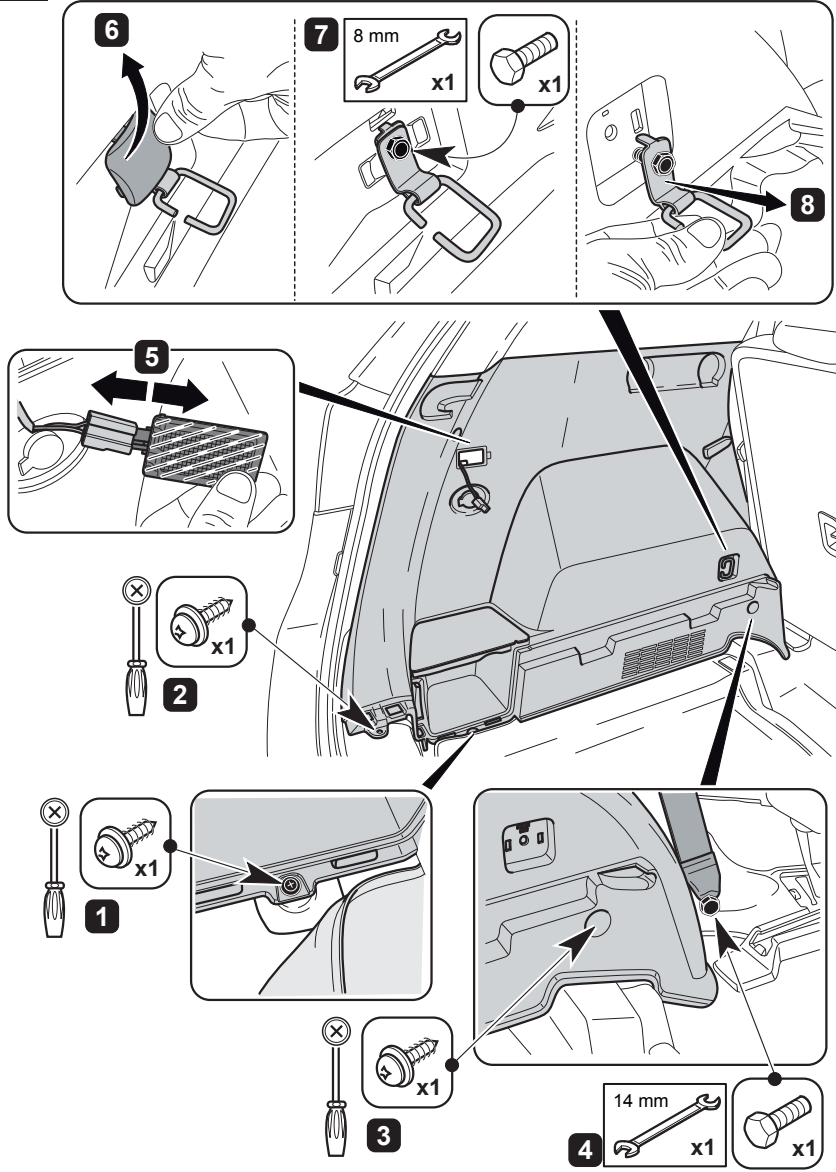

K0106

5

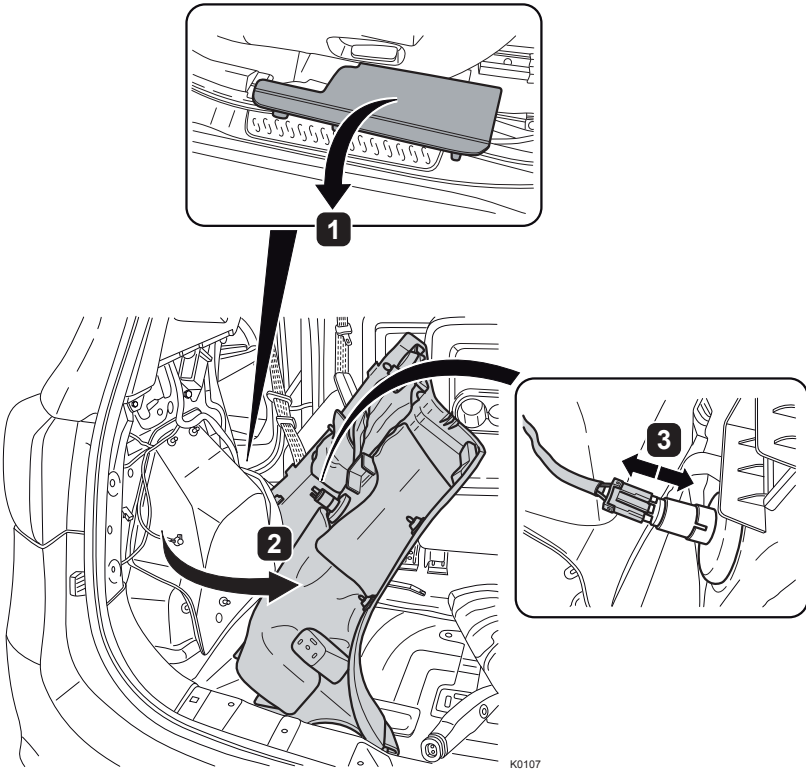

6

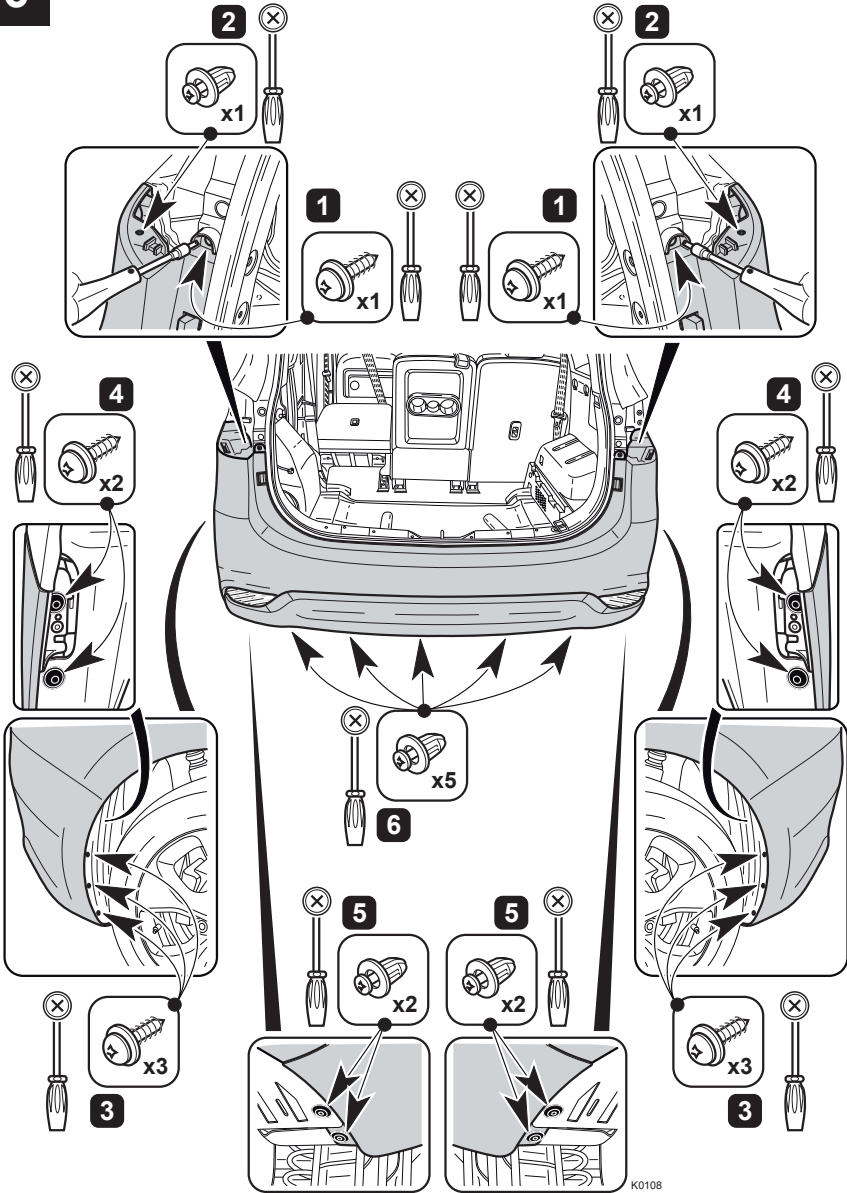

7

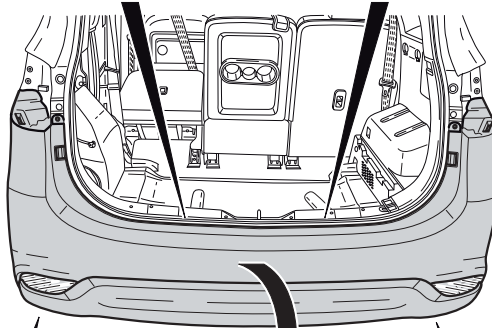
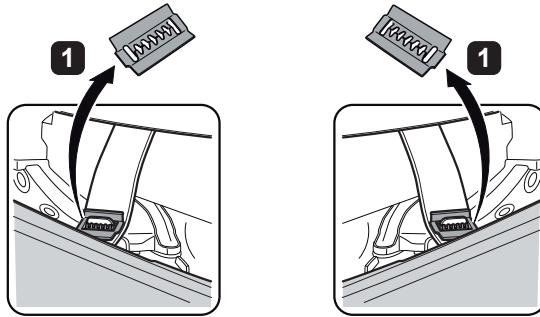

4

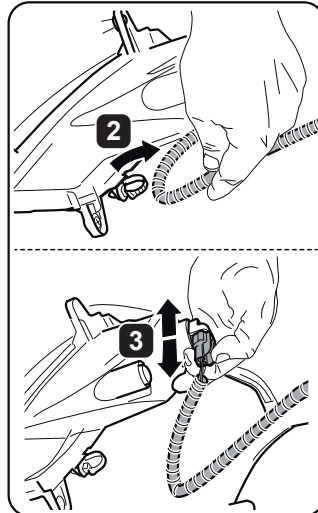
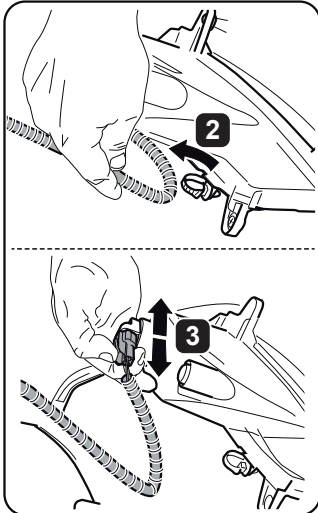

K0106

8

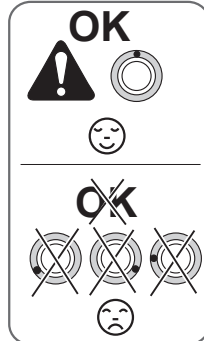
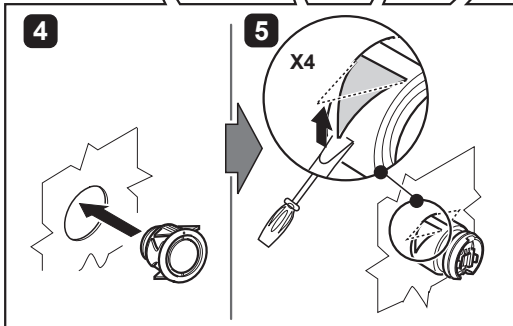
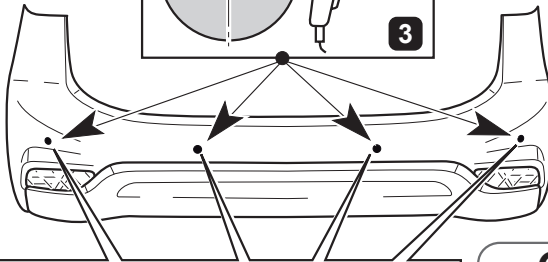
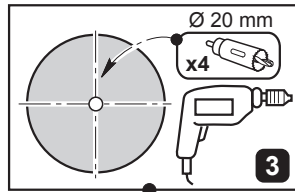
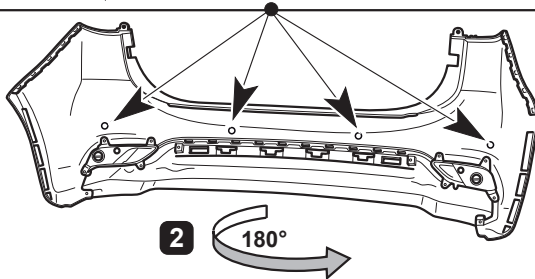
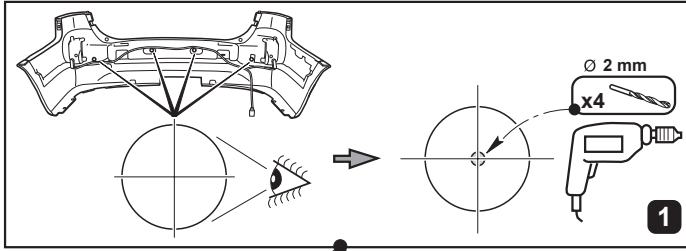

K0110

9

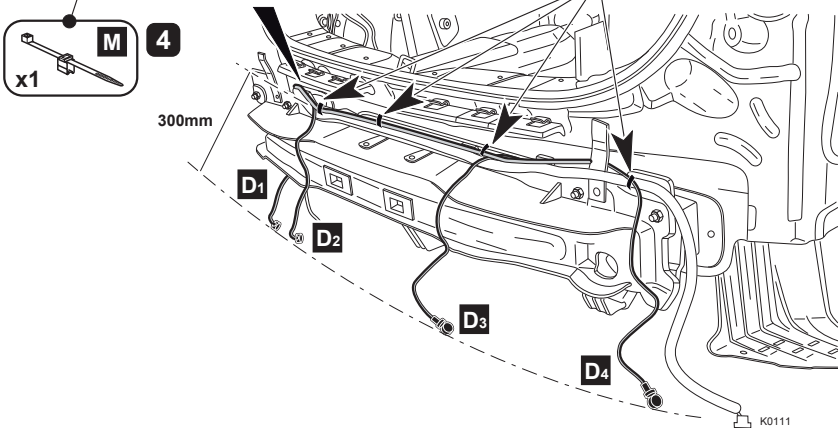
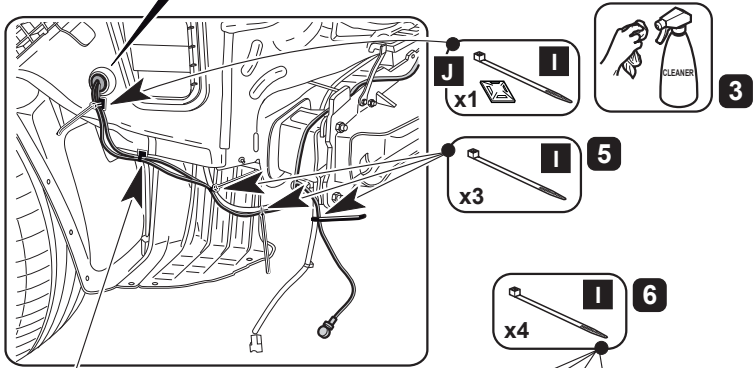
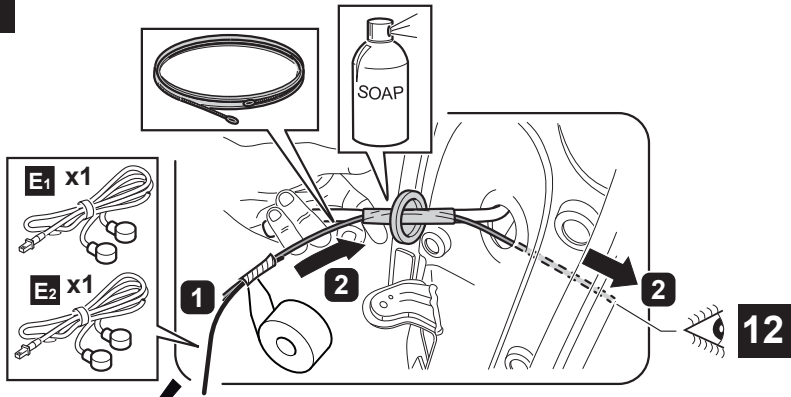

10

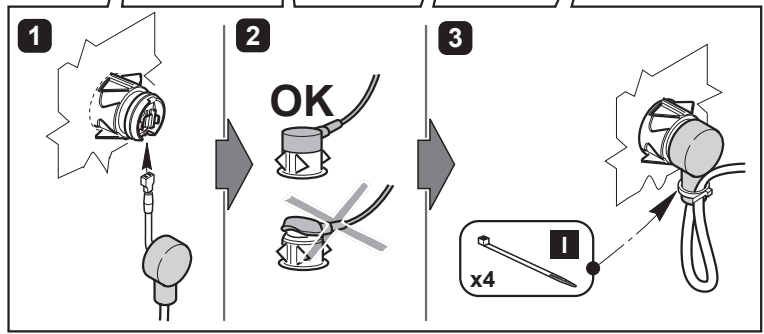
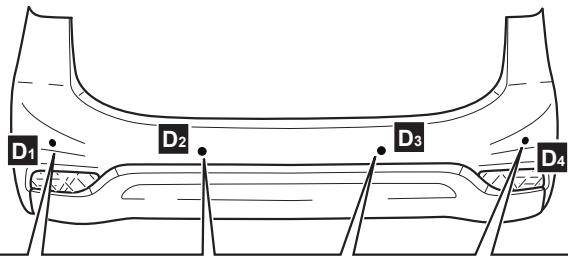

K0112

11

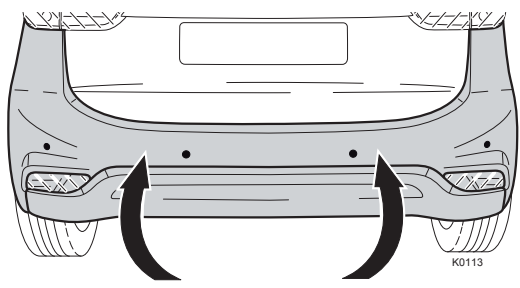

K0113

12

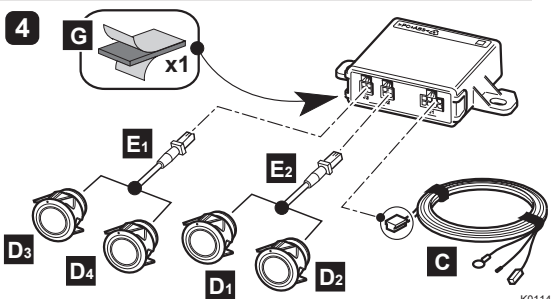
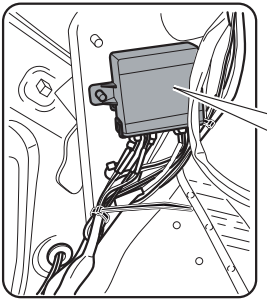
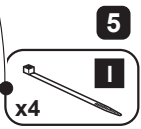
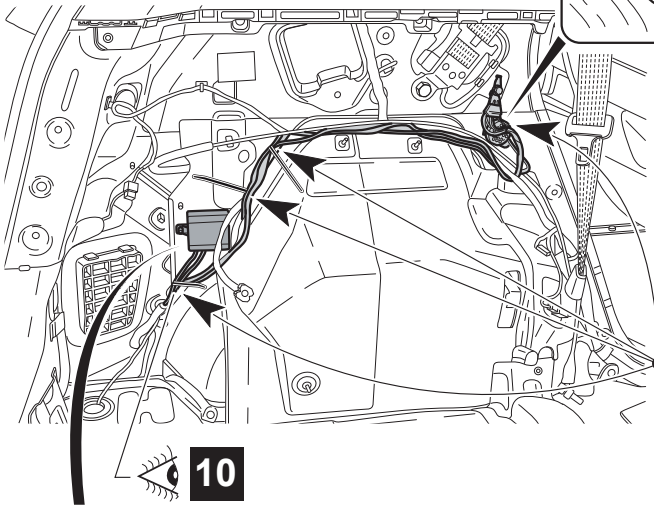
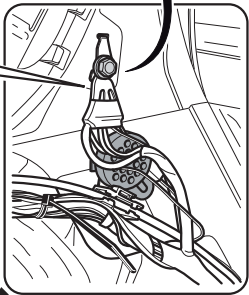
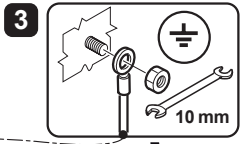
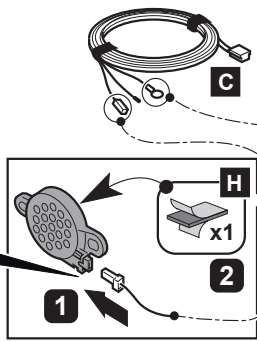
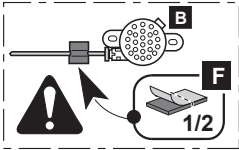
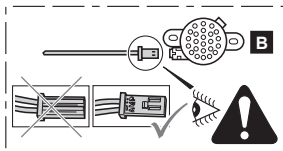

K0114

13

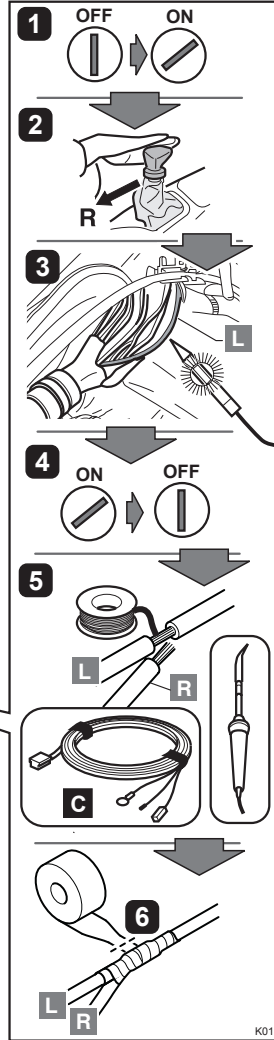
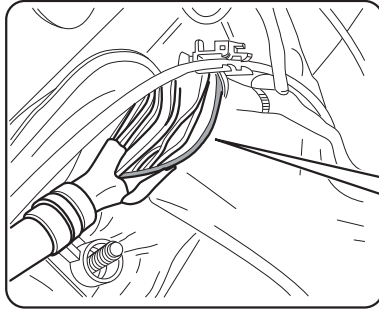
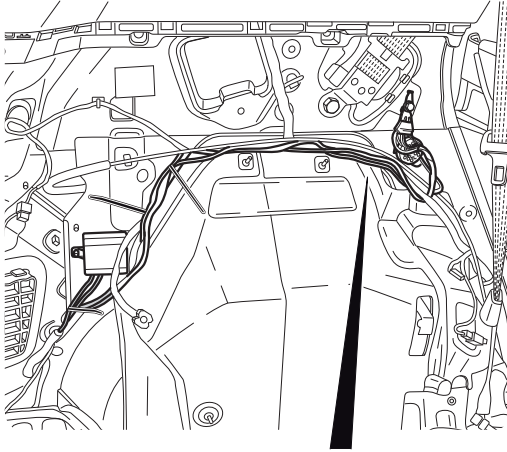





K0115

R	RED	ROT	ROUGE	ROOD	ROD	ROSSO	ROD
VERMELHO	ROJO	ROD	ČERVENÁ	PUNAINEN	CZERWONY	КРАСНЫЙ	ČERVENÝ
L	LIGHT BLUE	HELLBLAU	AZUR	LICHTBLAUW	HIMMELBLÁ	AZZURRO	LYSEBLÁ
AZUL-CLARO	CELESTE	LJUSBLÁ	MODRA	VAALEANSININEN	LAZUROWY	СИНИЙ	SVETLOMODRÁ

14

SETUP

 3	sensitivity  1	 3	 3
---	---	---	---

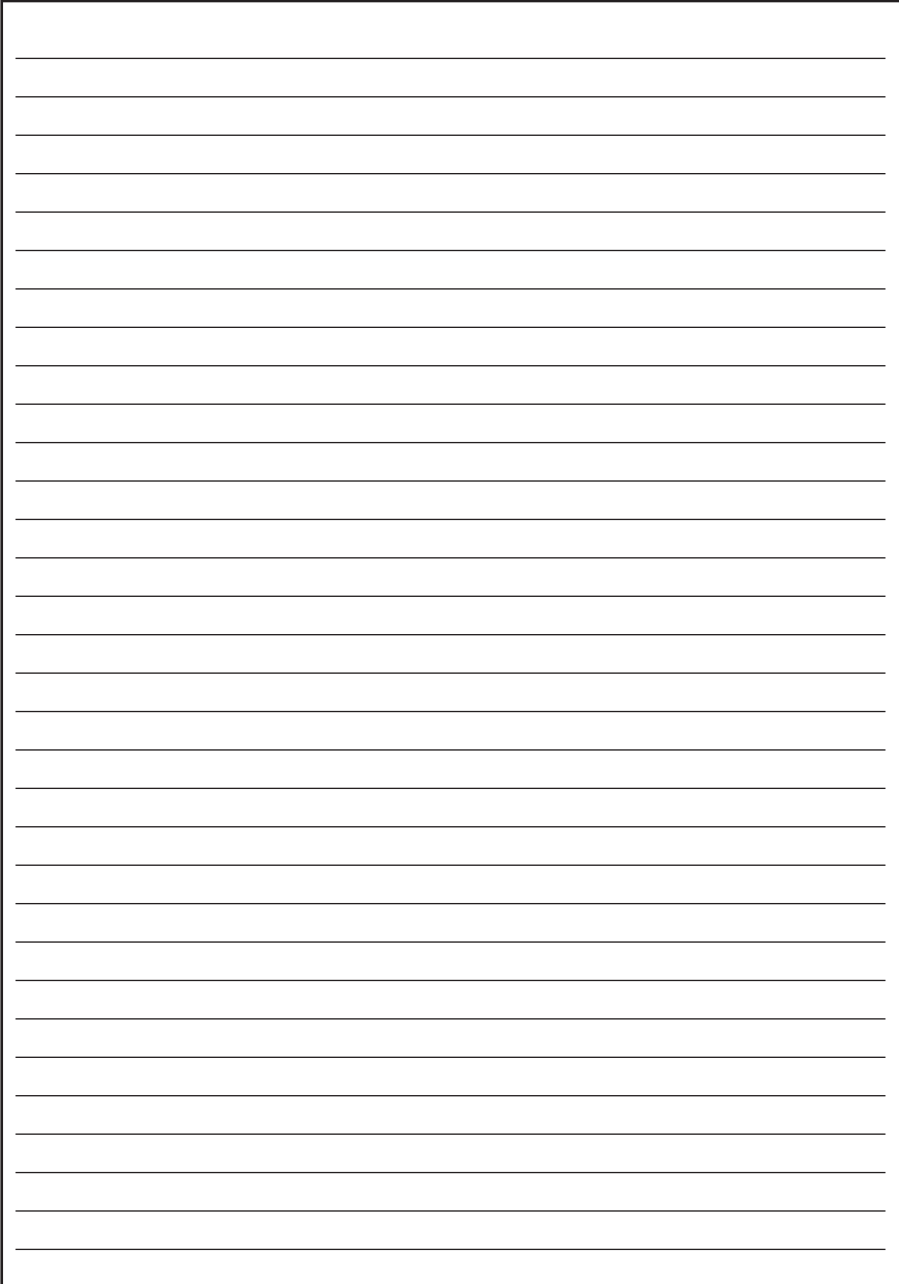

K0116

A large rectangular box with a black border, containing 25 horizontal lines for writing. The lines are evenly spaced and extend across the width of the box. There are four registration marks (crosshairs) located at the top, bottom, left, and right centers of the page.

A large rectangular box with a black border, containing 25 horizontal lines for writing. The lines are evenly spaced and extend across the width of the box. The box is centered on the page.

