



2h

PART-NO.: 66602ADE00

GENUINE ACCESSORIES

PARKING DISTANCE CONTROL - FRONT -

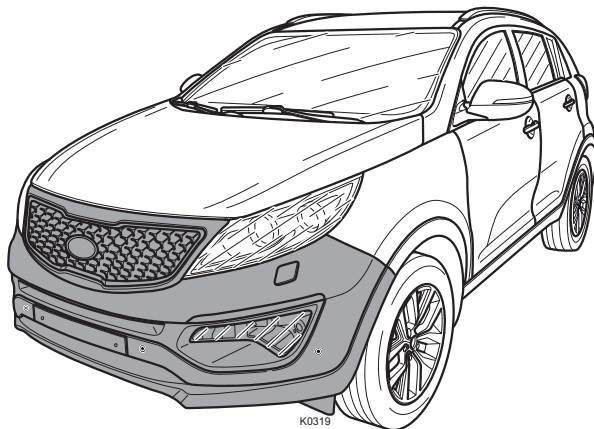

K0319

06DE3934A_12/2013

SPORTAGE F/L 2014

PRE-INSTALLATIONS CAUTIONS/NOTES:

GB

We would expressly point out that assembly not carried out properly by a competent installer will result in cancellation of any right to damage compensation, especially the right required by the laws in terms of warranty.

Contents of these kits and their fitting manuals are subject to alteration without notice, please ensure that these instructions are read and fully understood before commencing installation.

DE

Beachten Sie bitte, dass bei Schäden in Folge unsachgemäßen Einbaus sämtliche Garantieansprüche erlöschen, insbesondere solche, die das Produkthaftungsgesetz betreffen.

Das Recht zu Änderungen an Inhalt von Montagesatz und Einbauanleitungen ohne Vorankündigung bleibt vorbehalten. Lesen Sie vor dem Einbau diese Anleitung sorgfältig und gewissenhaft durch.

FR

Nous tenons à insister tout particulièrement sur le fait que si ce produit n'est pas correctement assemblé par un technicien compétent, aucun droit de compensation ne sera recevable en cas de dommages, notamment les droits en vertu de la loi concernant la responsabilité à l'égard du garant.

Le contenu de ces kits, ainsi que des guides de montage qui les accompagnent est sujet à modifications sans préavis ; lisez attentivement ces instructions avant de procéder à l'installation.

NL

We zouden expliciet willen benadrukken dat installatie die niet correct wordt uitgevoerd door een bekwaame installateur kan leiden tot het vervallen van elk recht op schadecompensatie, vooral de compensatie op basis van de garantie.

De inhoud van deze kits en de installatiehandleidingen kunnen worden gewijzigd zonder kennisgeving. Zorg er dus voor dat u deze instructies hebt gelezen en volledig begrijpt voordat u met de installatie begint.

DK

Det skal understreges, at montering, der udføres af en ikke-kvalificeret montør, medfører bortfald af enhver ret til erstatning særligt i forbindelse med erstatningskrav, der måtte opstå i kraft af loven om produkt garanti.

Sættens indhold og monteringsvejledninger kan ændres uden varsel, og vejledningerne skal derfor læses og forstås, før monteringen påbegyndes.

IT

Facciamo espressamente notare che il montaggio non corretto eseguito da un installatore competente comporterà la cancellazione di qualsiasi diritto di risarcimento danni da parte dell'utente, in particolare il diritto previsto dalle leggi in termini di garanzia.

I contenuti di questi kit e i relativi manuali di installazione sono soggetti a modifica senza preavviso. Si raccomanda di leggere attentamente e integralmente tali istruzioni e di sincerarsi di averle comprese prima di procedere all'installazione.

NO

Vi bemerker at montasje som ikke utføres korrekt, av en kompetent installatør, vil resultere i annullering av all rett til erstatning for enhver skade, spesielt de som oppstår garanti.

Innholdene i disse sett og deres monteringsanvisninger kan endres uten forvarsel. Vennligst påse at disse instruksjonene leses grundig og er erstatt innen installasjonen startes.

PT

Gostaríamos de ressaltar expressamente que a montagem não realizada corretamente por um instalador competente irá resultar no cancelamento de qualquer direito a indemnização de danos, nomeadamente as que decorrem por virtude do acto de responsabilidade do garantia.

Índice desses kits e seus manuais de montagem estão sujeitos a alteração sem aviso prévio, certifique-se que estas instruções são lidas e completamente entendidas antes de começar a instalação.

ES

Una vez más, hacemos hincapié en el hecho de que si este producto no lo monta correctamente un técnico instalador cualificado, se anulará cualquier derecho de compensación por posibles daños, especialmente los relativos a la legislación vigente sobre este tipo de garantía.

El contenido De los kits y sus correspondientes manuales De montaje están sujetos a posibles modificaciones sin previo aviso. Es importante que lea con atención todas las instrucciones y que las entienda perfectamente antes De iniciar la instalación.

SE

Vi vill uttryckligen meddela att montering som inte görs fackmannamässigt av en kompetent montör, kommer att häva rätten till kompensation för skador, speciellt rättigheter enligt lagen om produktansvar garanti.

Innehållet i dessa satsar och deras bruksanvisningar kan komma att ändras utan föregående meddelande. Vänligen läs dessa anvisningar noga innan du påbörjar monteringen.

CZ

Upozorňujeme, že instalace provedená nesprávně nebo nekompetentní osobou, ruší veškerá práva na kompenzaci škod, obzvláště způsobených poruchou záruka.

Obsah těchto sad a návody na jejich montáž podléhají změnám bez předchozího upozornění. Prosím, ujistěte se, že jste si pokyny před instalací přečetly a dostatečně jim rozumíte.

FI

Jos asennuksen suorittaa joku muu kuin pätevä ammattilainen, tämä kumoo asiakkaan oikeuden vahingonkorvauksiin, erityisesti sellaisiin, jotka perustuvat tuotevastuulakiin.

Kiinnitysarjan sisältöä ja asennusoppaita voidaan muuttaa siitä etukäteen ilmoittamatta. Asiakkaan tulee ennen asennuksen aloittamista perehtyä huolellisesti näihin ohjeisiin.

PL

Pragniemy zwrócić uwagę na fakt, że nieprawidłowy montaż przeprowadzony przez niekompetentne osoby będzie podstawą do unieważnienia wszelkich praw do odszkodowań, w szczególności wynikających z zestaw o odpowiedzialności za gwarancja.

Zawartość opisanych zestawów i instrukcje ich montażu mogą ulegać zmianom bez powiadomienia; przed rozpoczęciem instalacji należy zapoznać się z instrukcjami i upewnić się, że zostały zrozumiane.

RU

Обратите при повреждении, возникших в результате неправильного монтажа, истрекуйте все виды гарантии, в частности, касающиеся закона, регулирующего ответственность за качество продукции гарантии.

Право изменения содержания монтажного комплекта и инструкции по установке без предварительного оповещения производитель оставляет за собой. Внимательно прочитайте инструкцию перед тем, как начать установку.

SK

Pripomíname, že v prípade chybné inštalácie vykonanej nekompetentným inštalátorom používateľ stráca akýkoľvek nárok na prípadné odškodnenie ako aj akékoľvek zákonní dané právo týkajúce sa zodpovednosti záruky.

Obsahy týchto súprav a príslušné návody na inštaláciu môžu byť zmenené bez predchádzajúceho upozornenia. Odporúčame pozorne si prečítať všetky uvedené pokyny a uistiť sa o ich pochopení ešte pred vykonaním inštalácie.

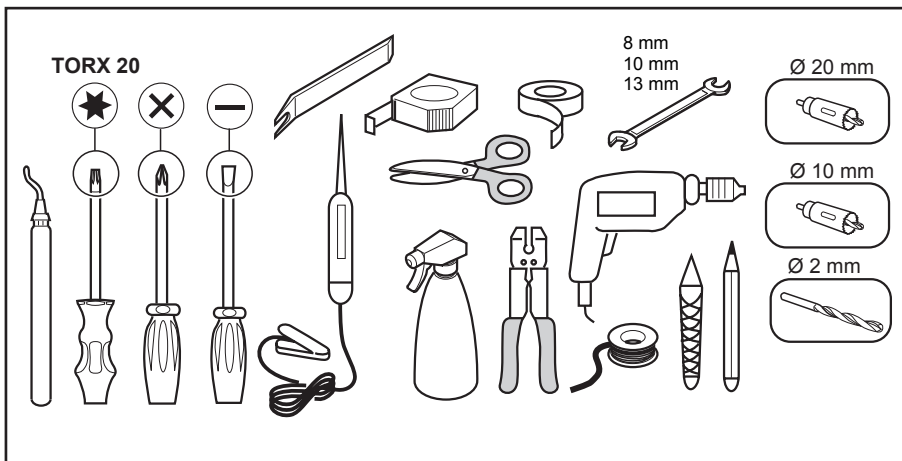

PART LIST - Parking Distance Control (66602ADE00)

GB Part list

DE Einzelteilliste

FR Liste de pieces

NL Onderdelenlijst

DK Del-list

IT Elenco componenti

NO Delliste

PT Lista de peças

ES Lista de componentes

SE Dellista

CZ Seznam dílů

FI Osaluettelo

PL Lista części

RU Список составных частей

SK Zoznam dielov

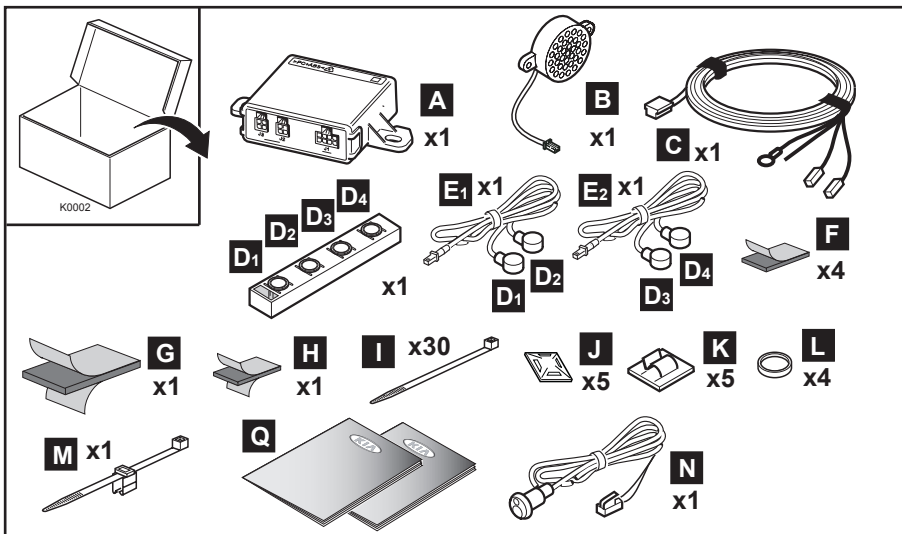

CONNECTIONS - Parking Distance Control (66602ADE00)

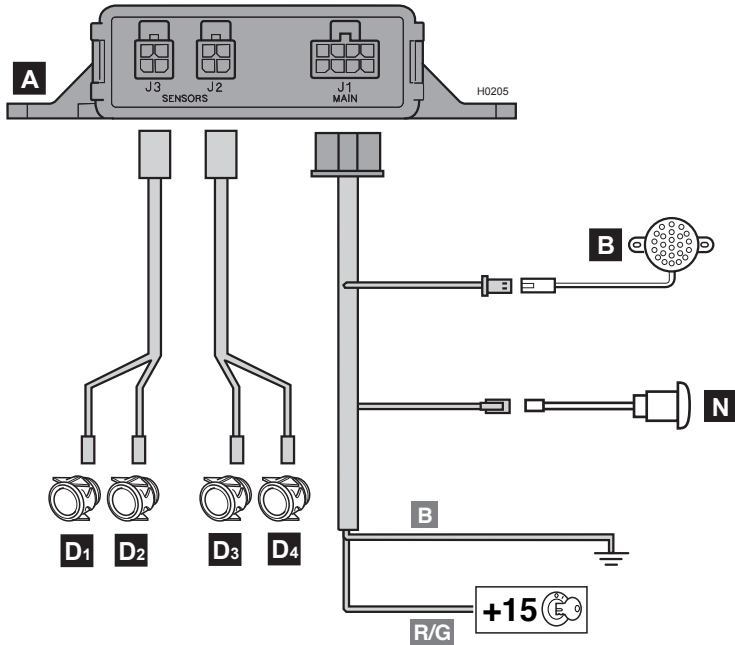

R	RED	ROT	ROUGE	ROOD	ROD	ROSSO	ROD
VERMELHO	ROJO	ROD	ČERVENÁ	PUNAINEN	CZERWONY	КРАСНЫЙ	ČERVENÝ

B	BLACK	SCHWARZ	NOIR	ZWART	SORT	NERO	SVART
PRETO	NEGRO	SVART	ČERNÁ	MUSTA	CZARNY	ЧЕРНЫЙ	ČIERNY

G	GREEN	GRÜN	VERT	GROEN	GRØN	VERDE	GRØNN
VERDE	VERDE	GRÜN	ZELENÁ	VIHREÄ	ZIELONA	ЗЕЛЕНА	ZELENÁ

PAINTING - Parking Distance Control (66602ADE00)

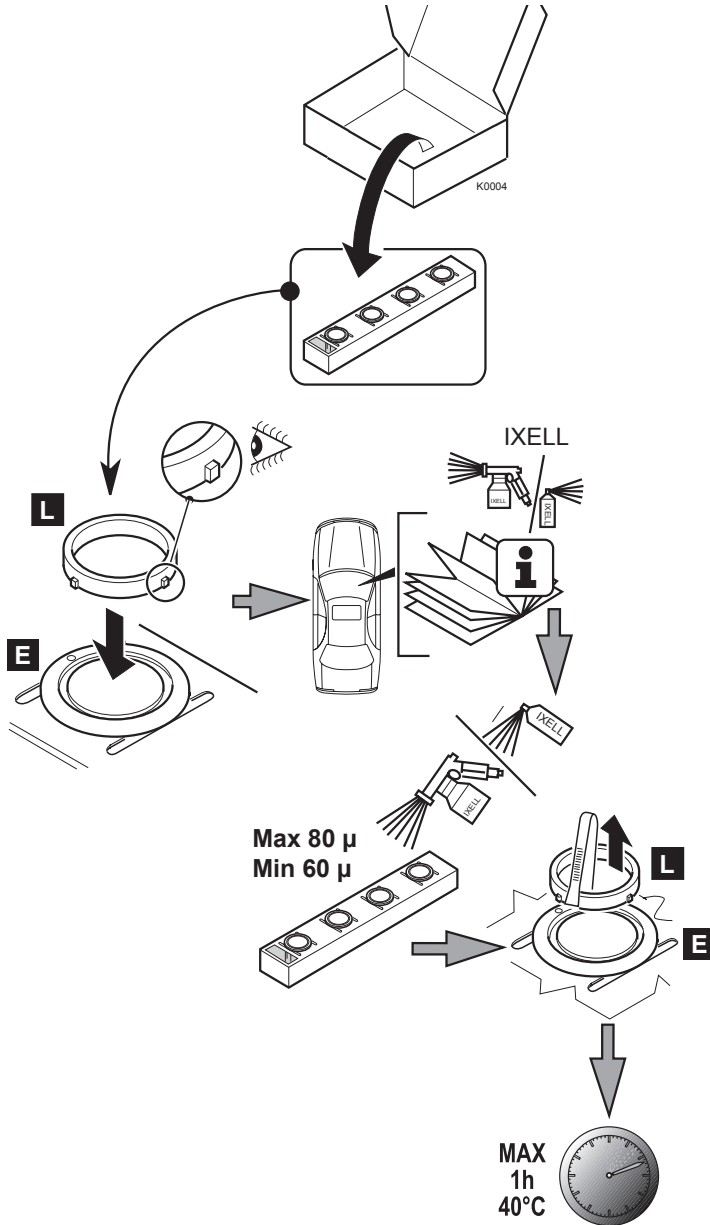

Ignition key
OFF

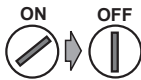

remove J2
e J3 sensor
connectors

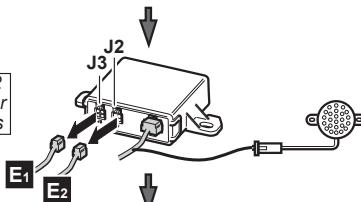

Ignition key
ON

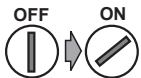

the system
beeps for 2
seconds

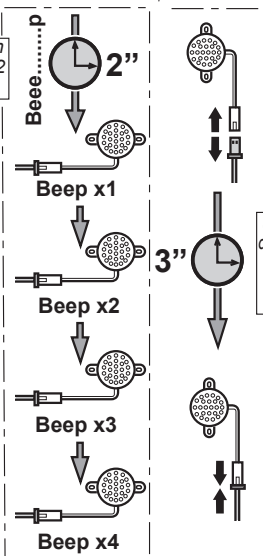

after beeping
disconnect the
buzzer for 3
seconds and
re-connect

exit from set-up programming by ignition key
OFF and re-connect J2 and J3 sensors
connectors

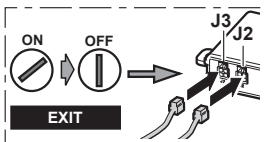

the system
beeps 6
time



Beep x1

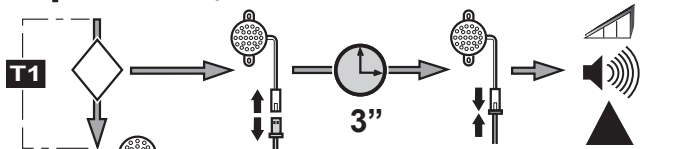

For speaker selection
disconnect the
speaker connector
during T1.
Keep it disconnected
minimum 3 sec and
reconnect it again.
Go to page 8

Beep x2

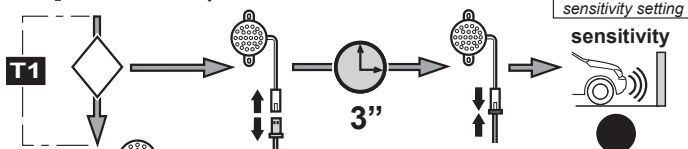

For speaker selection
disconnect the
speaker connector
during T1.
Keep it disconnected
minimum 3 sec and
reconnect it again.
Go to page 9

Beep x3

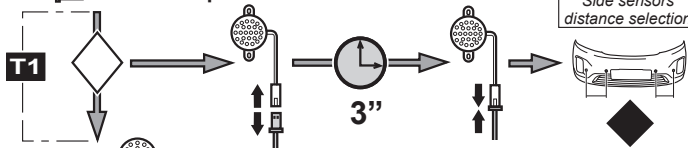

For speaker selection
disconnect the
speaker connector
during T1.
Keep it disconnected
minimum 3 sec and
reconnect it again.
Go to page 10

Beep x4

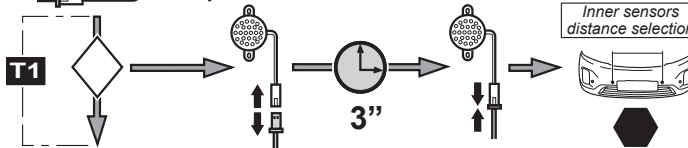

For speaker selection
disconnect the
speaker connector
during T1.
Keep it disconnected
minimum 3 sec and
reconnect it again.
Go to page 11

exit from set-up programming by ignition key
OFF and re-connect J2 and J3 sensors
connectors

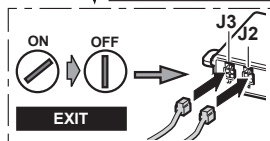



To enter the menu for setting the parameters disconnect for 3 seconds and reconnect the speaker connector

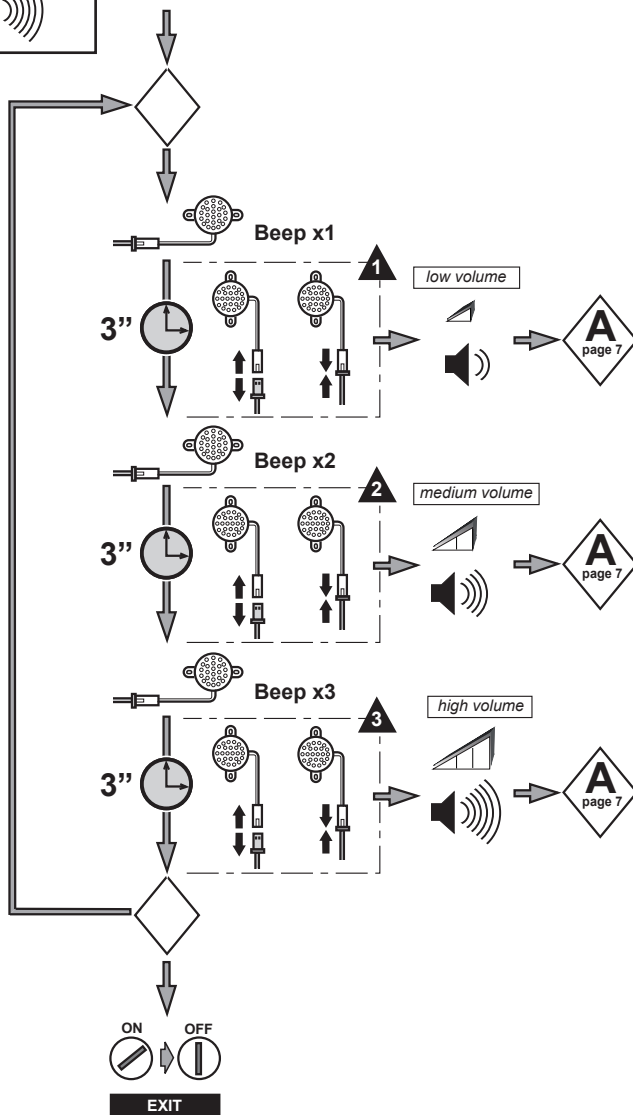

sensitivity



To enter the menu for setting the parameters disconnect for 3 seconds and reconnect the speaker connector

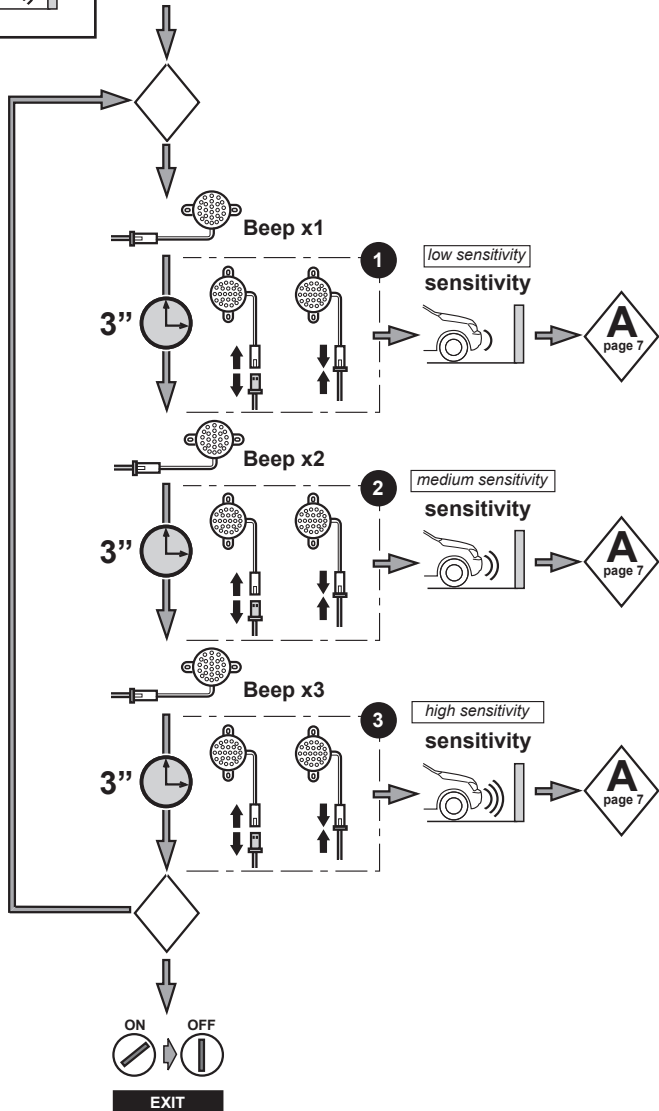

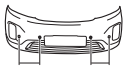

To enter the menu for setting the parameters disconnect for 3 seconds and reconnect the speaker connector

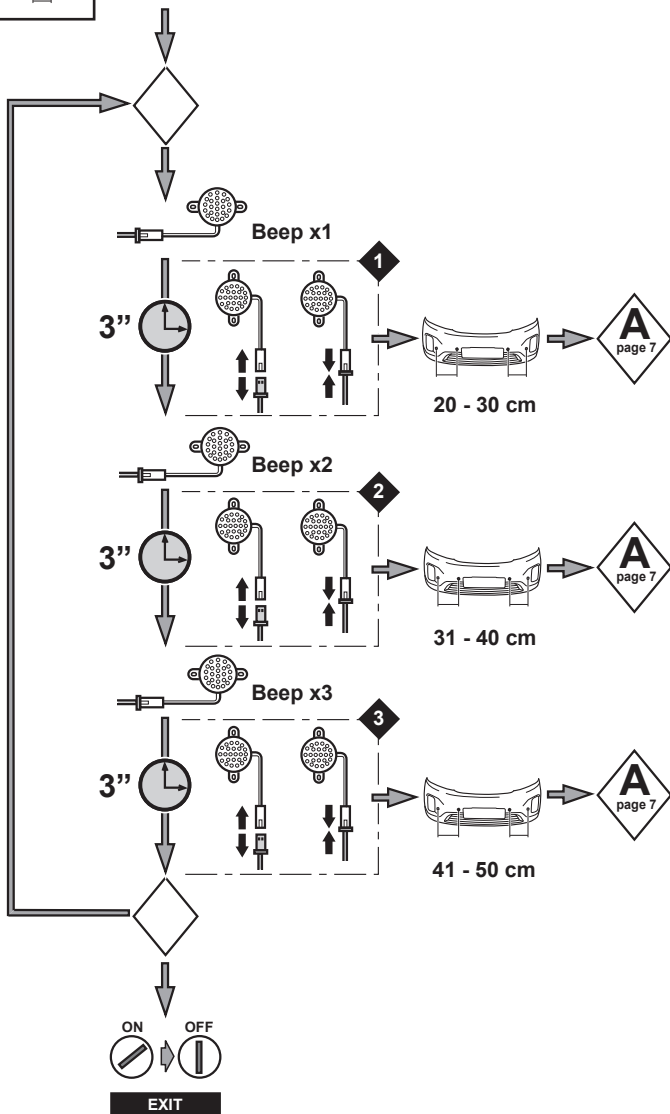



To enter the menu for setting the parameters disconnect for 3 seconds and reconnect the speaker connector

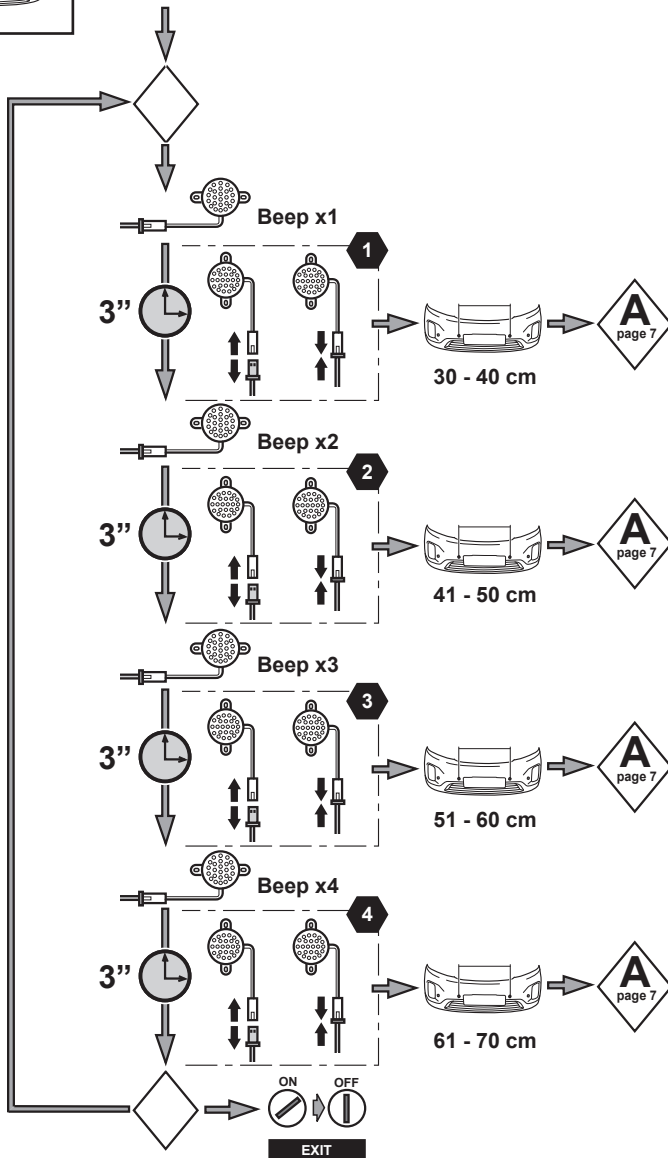

1

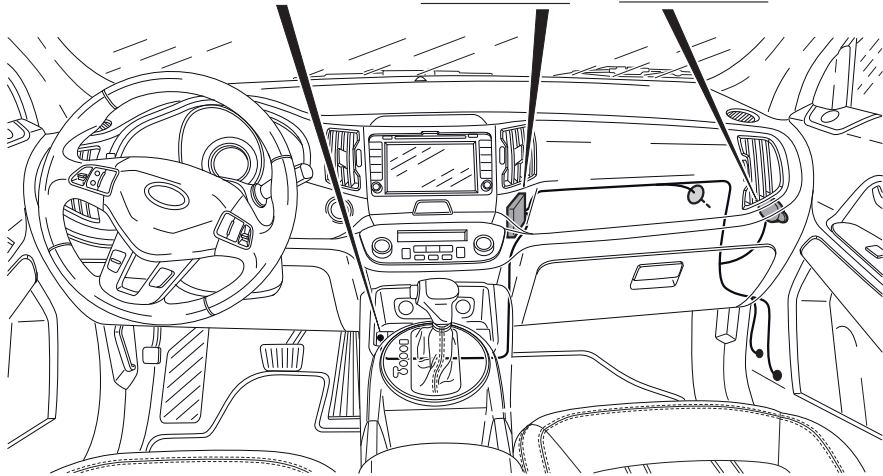
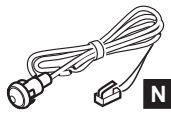

K0320

2

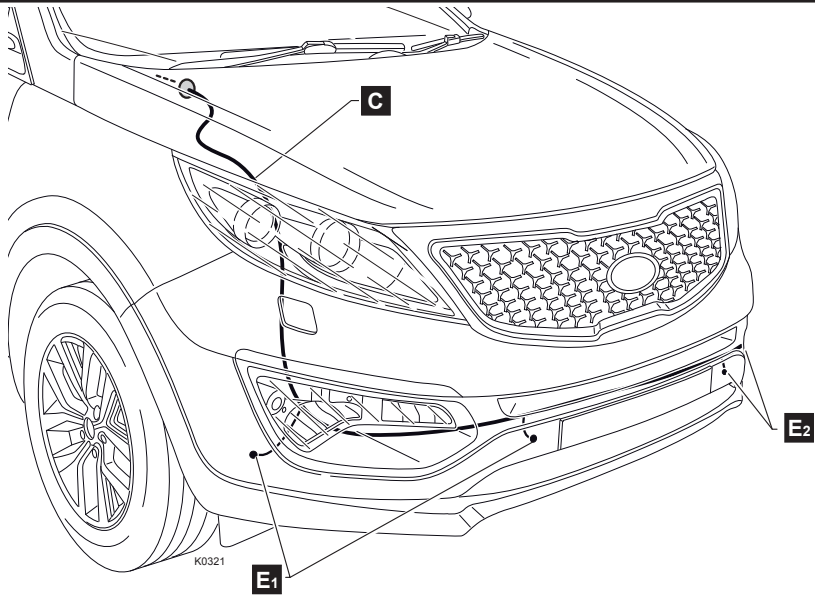

K0321

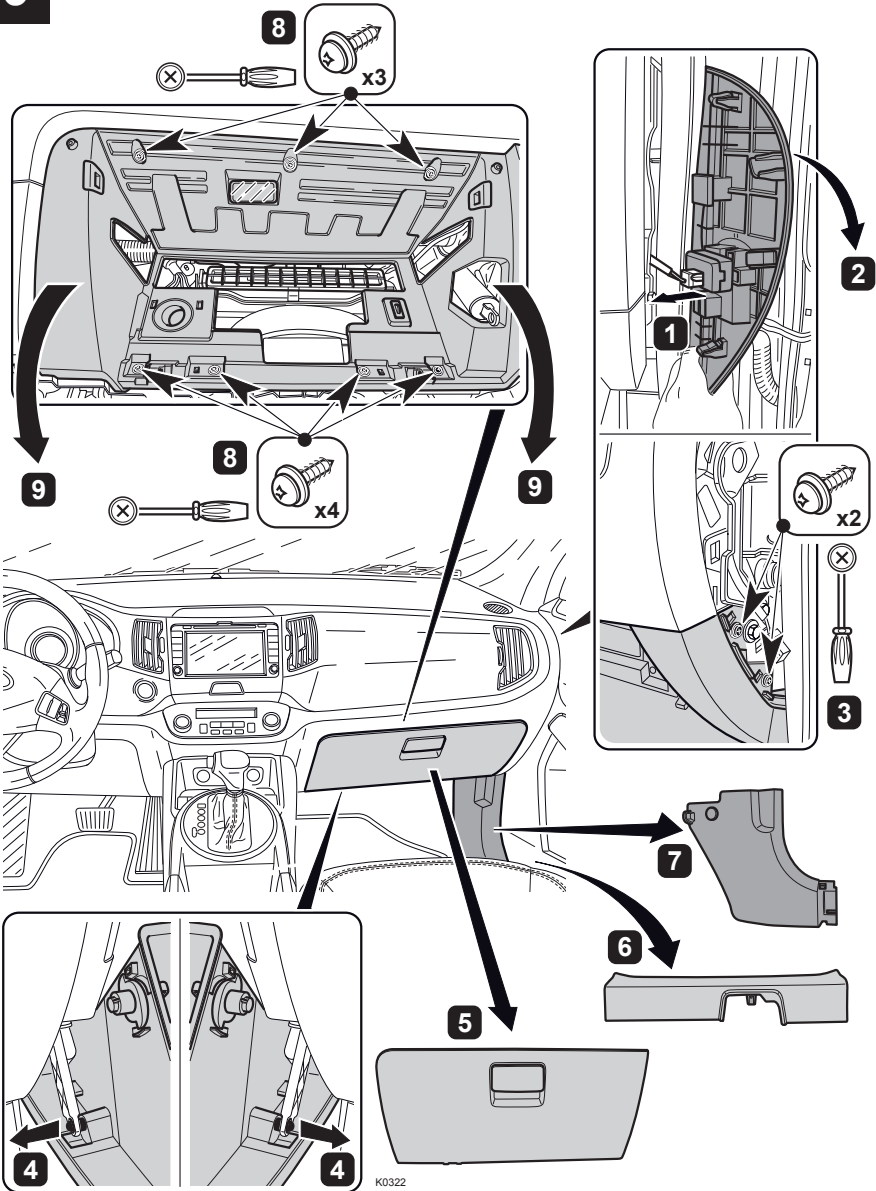

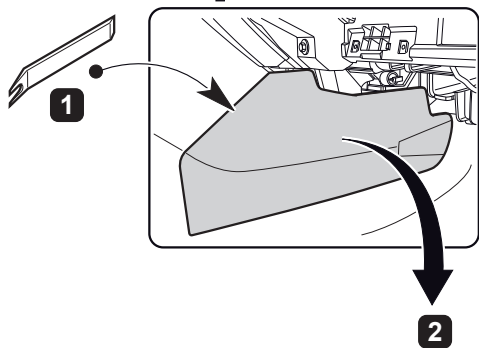
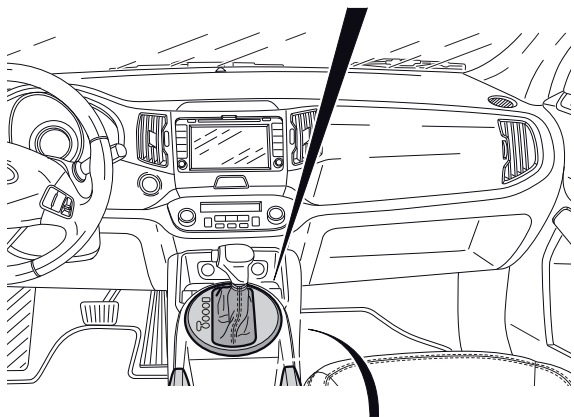
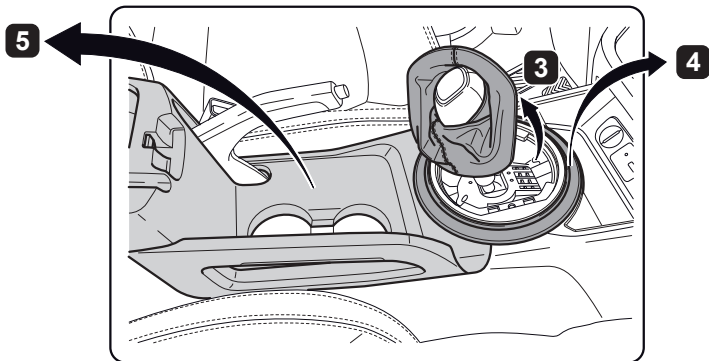

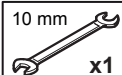
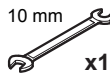
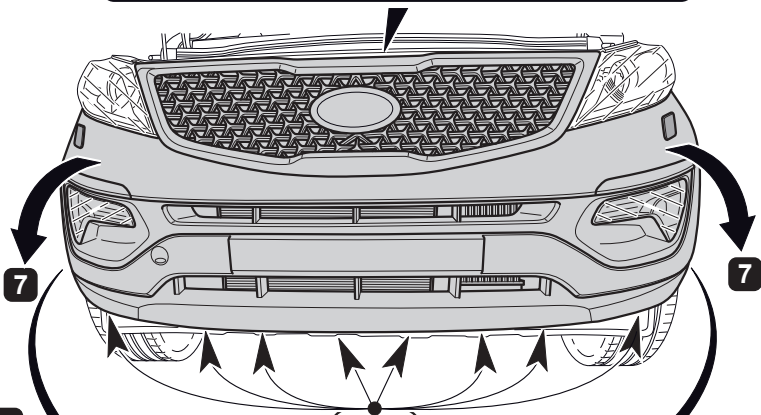
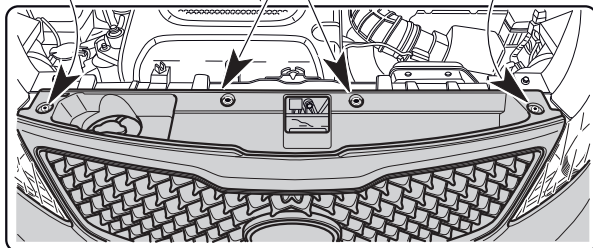
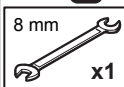
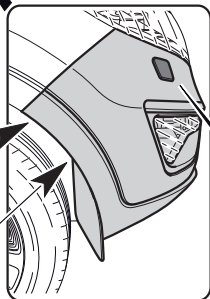
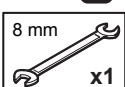
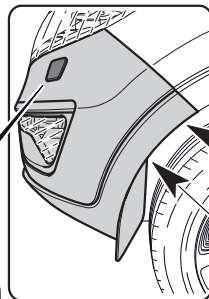
5**2****1****2****7****7****4****5****6****5****4****3**

K0327

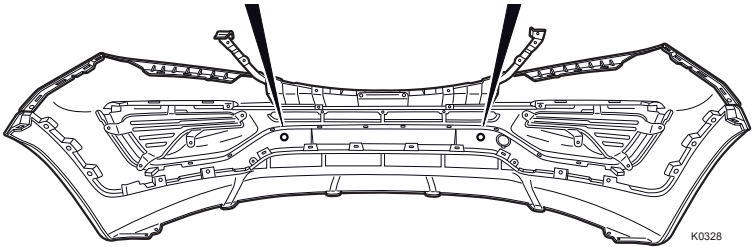
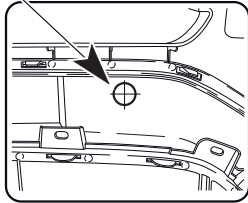
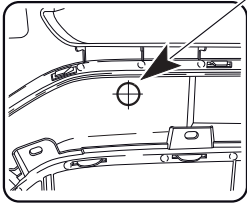
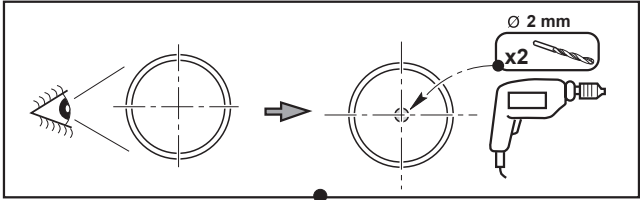

K0328

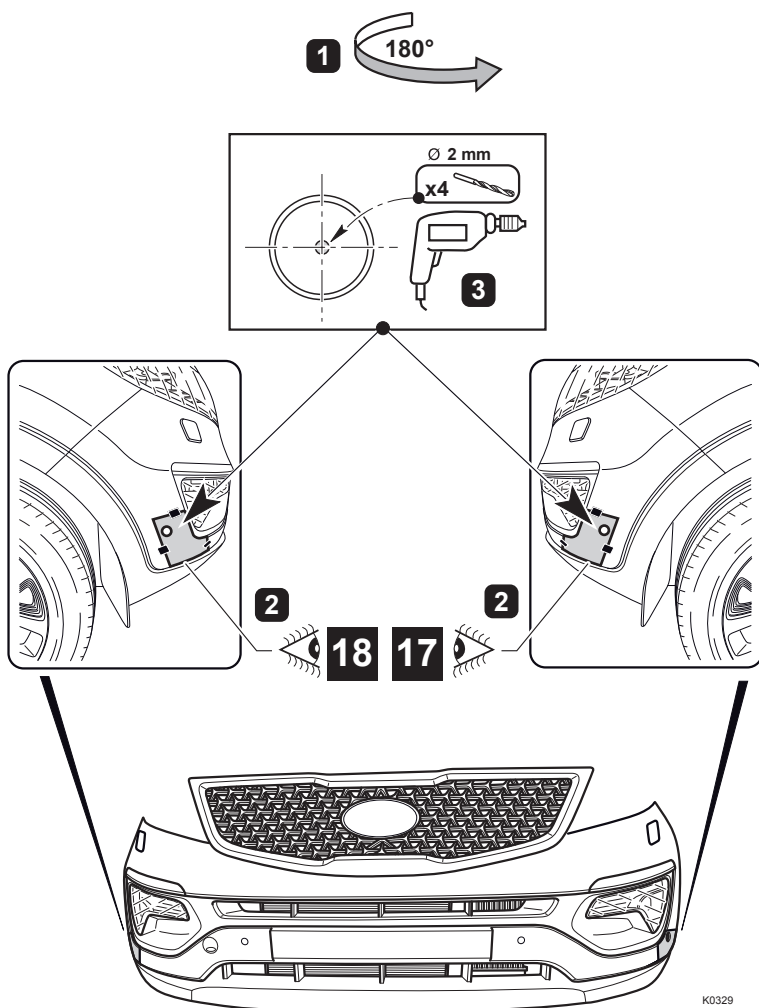

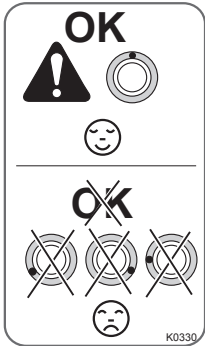
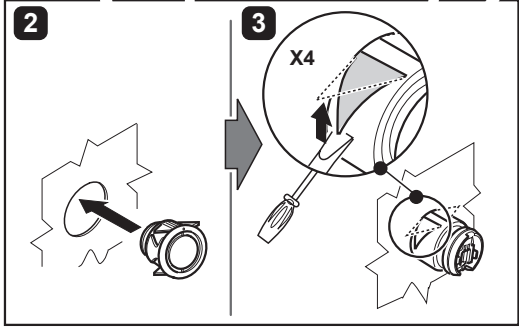
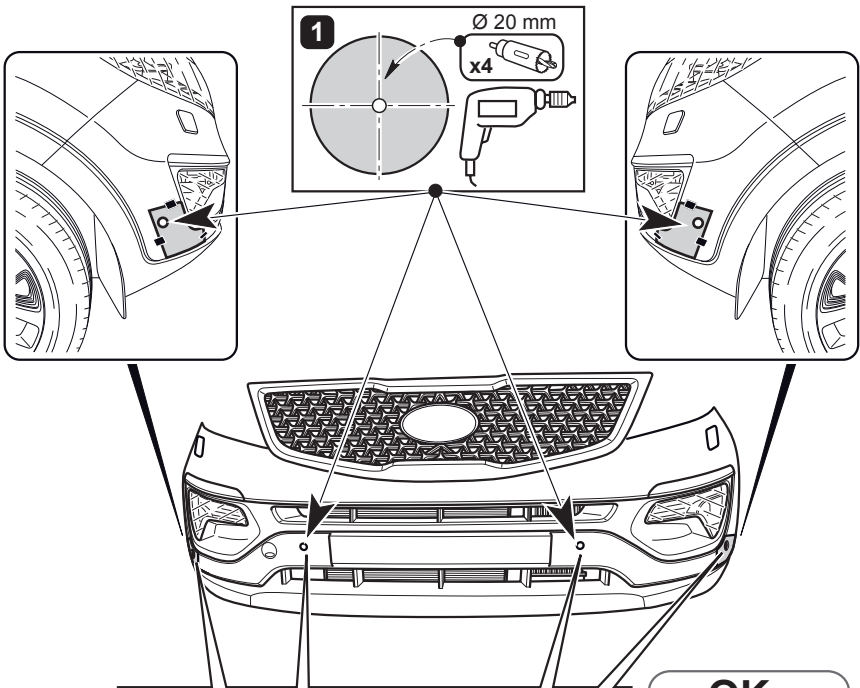

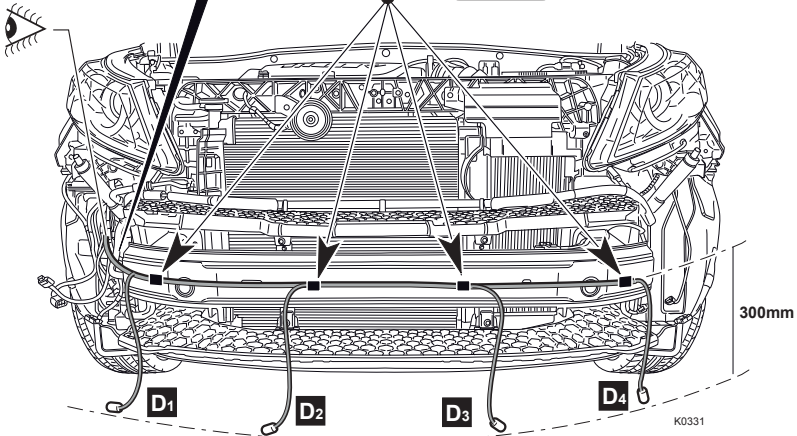
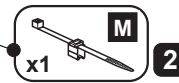
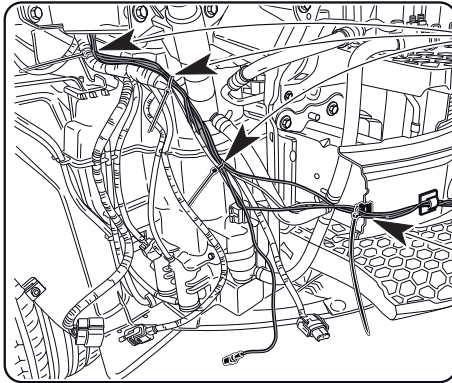

K0331

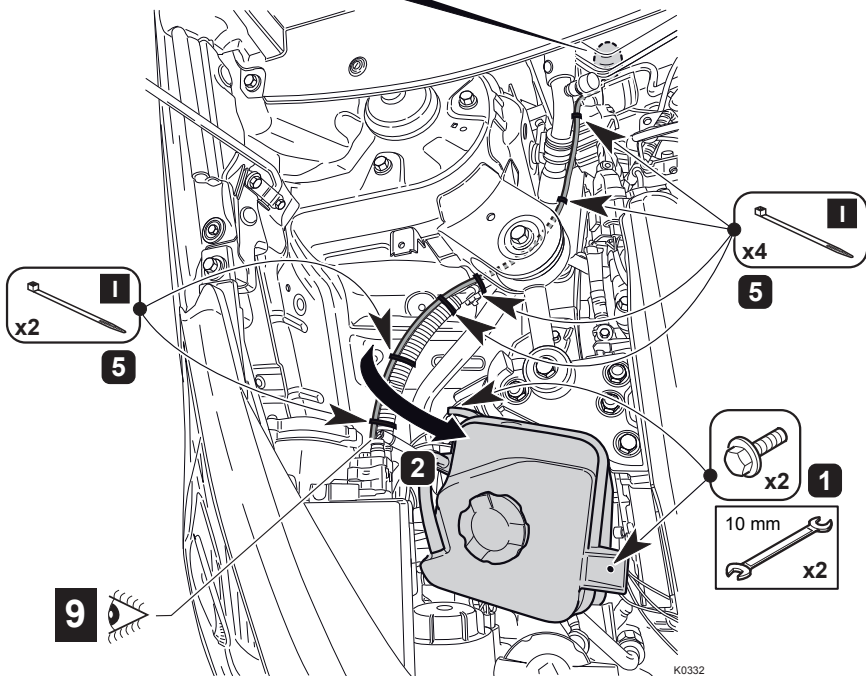
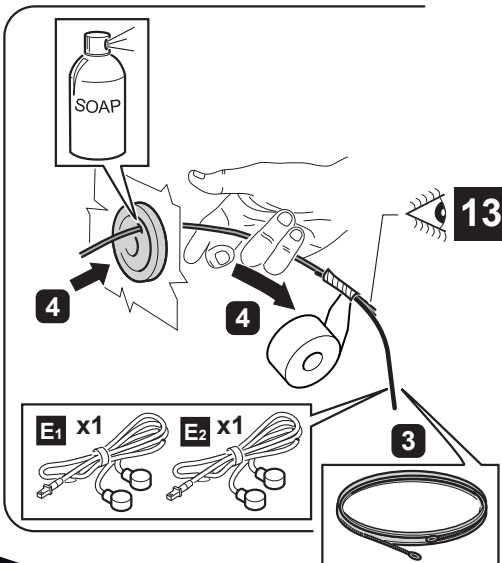
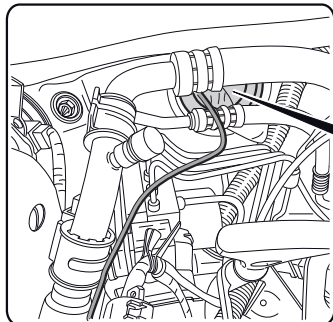

K0332

11

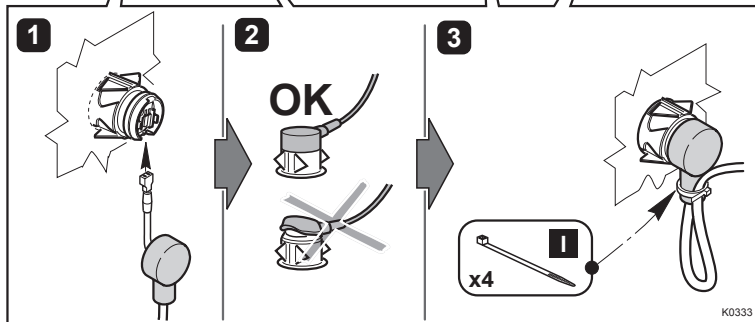
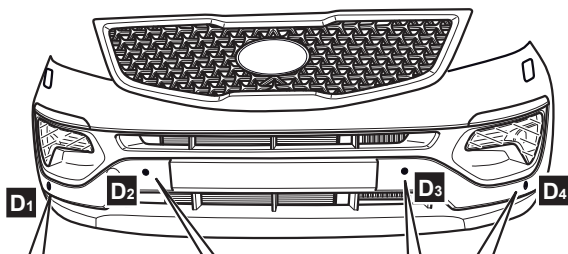

12

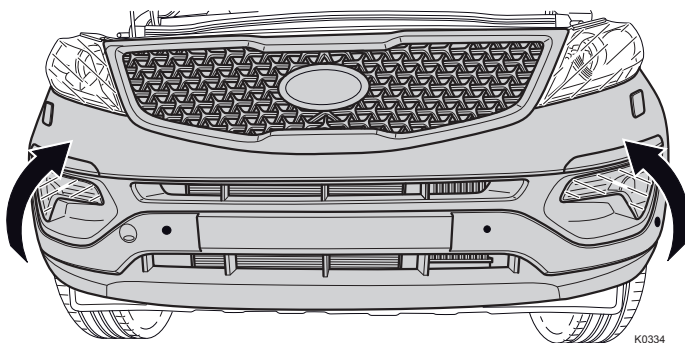

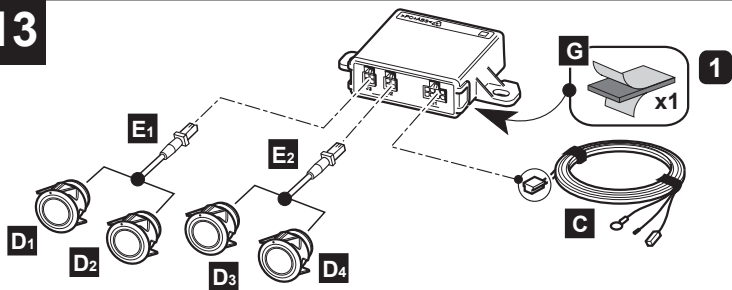
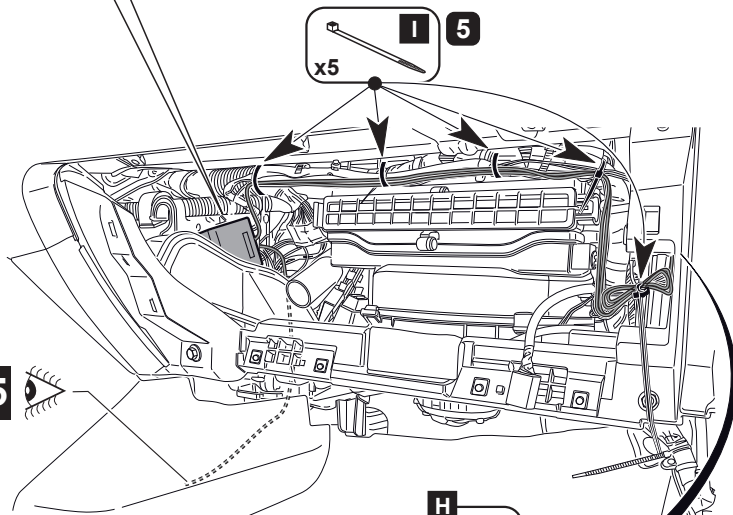
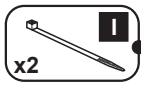
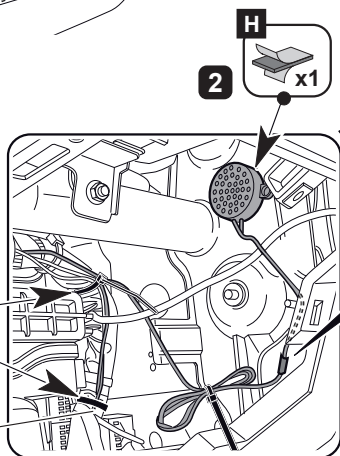
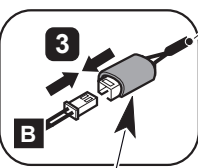
13**15****5****14****2****4****C**

K0335

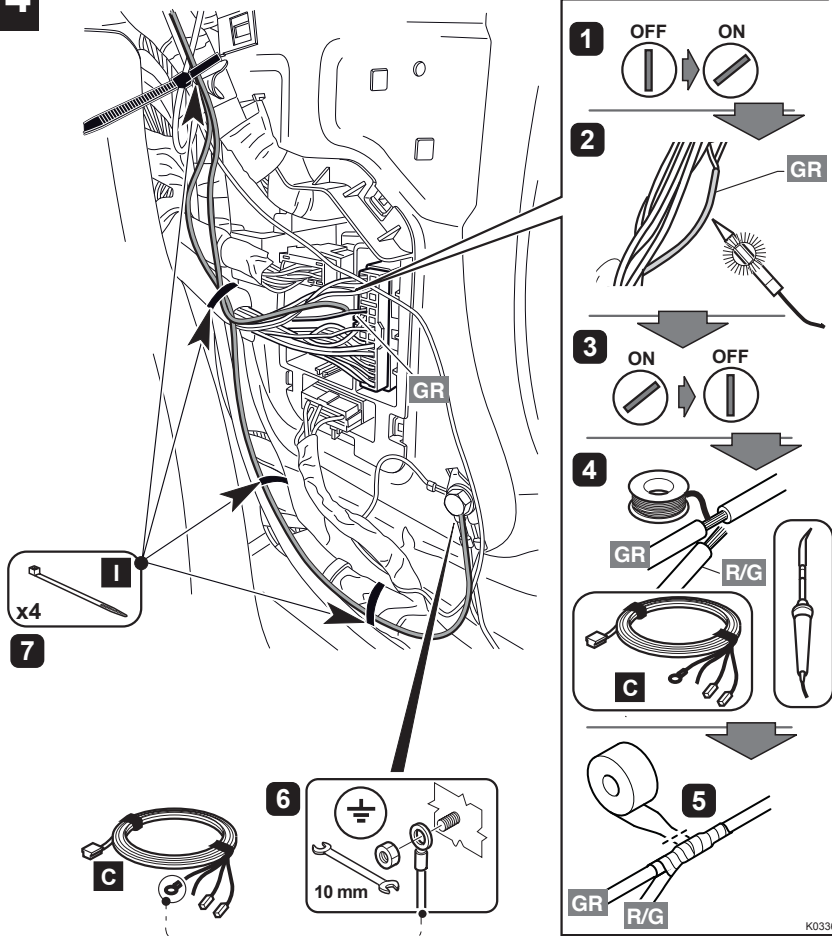

K0336

R	RED	ROT	ROUGE	ROOD	ROD	ROSSO	ROD
VERMELHO	ROJO	ROD	ČERVENÁ	PUNAINEN	CZERWONY	КРАСНЫЙ	ČERVENÝ

G	GREEN	GRÜN	VERT	GROEN	GRØN	VERDE	GRØNN
VERDE	VERDE	GRØN	ZELENÁ	VIHREÄ	ZIELONA	ЗЕЛЕНА	ZELENÁ

GR	GREY	GRAU	GRIS	GRIJS	GRÅ	GRIGIO	GRÅ
CINZENTO	GRIS	GRÅ	ŠEDÁ	HARMAA	SZARA	СЕРЫЙ	SIVÁ

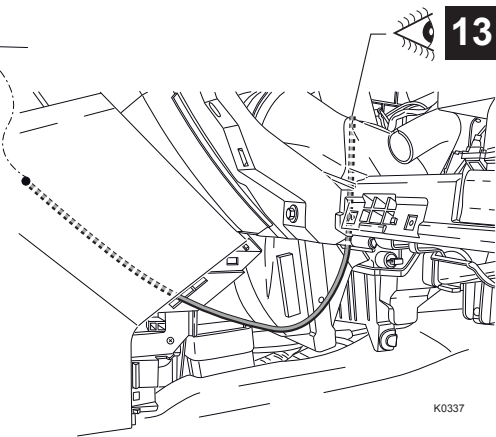
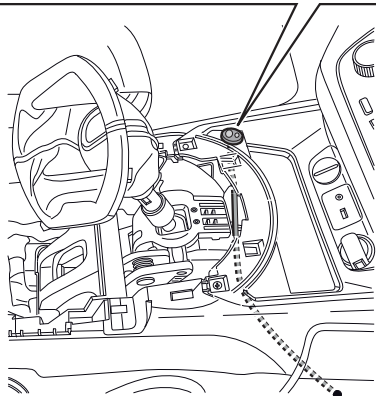
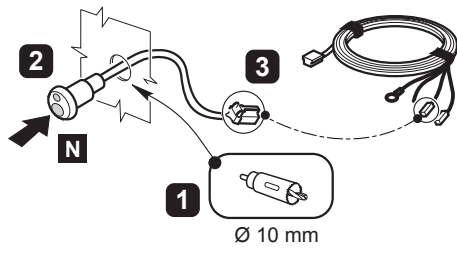

K0337

SETUP

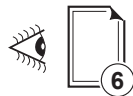
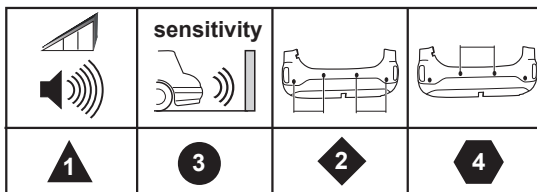

K0338



Sportage F/L 2014

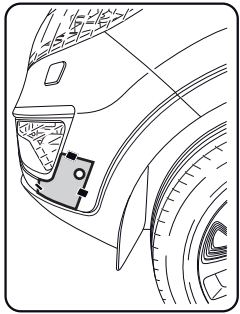
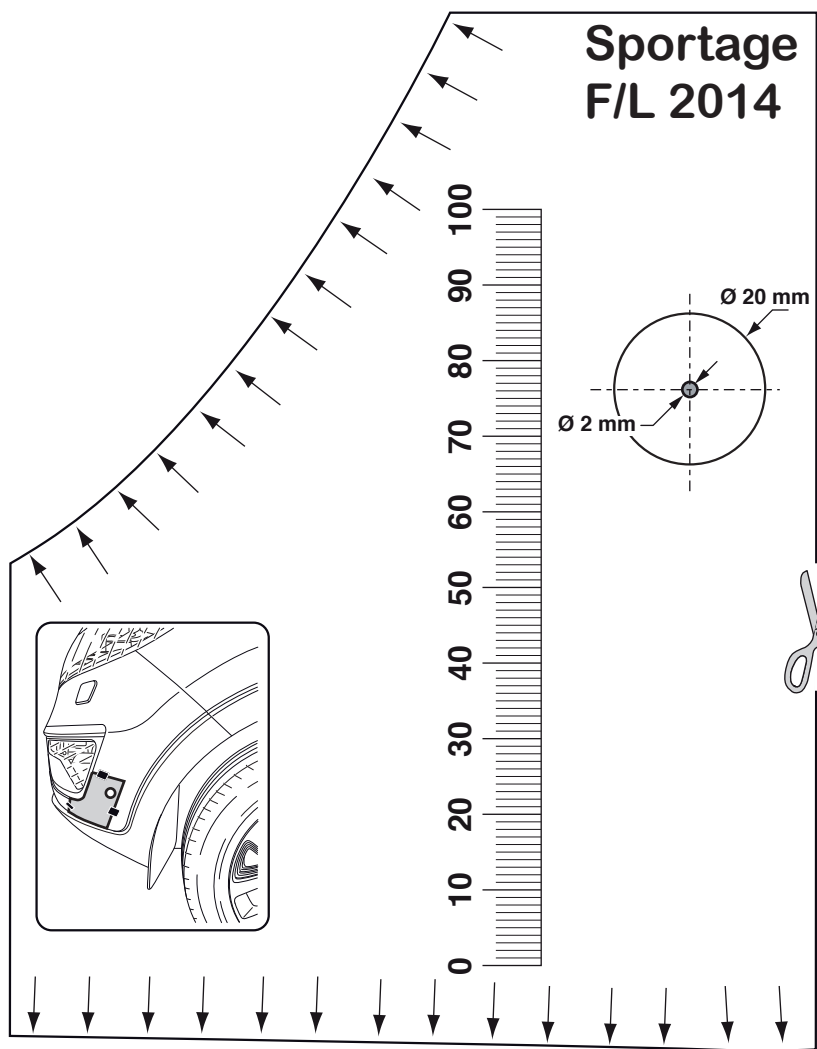

K0339



Sportage F/L 2014

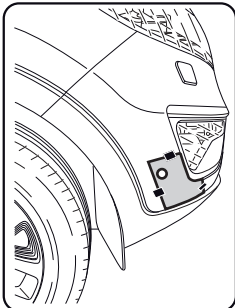
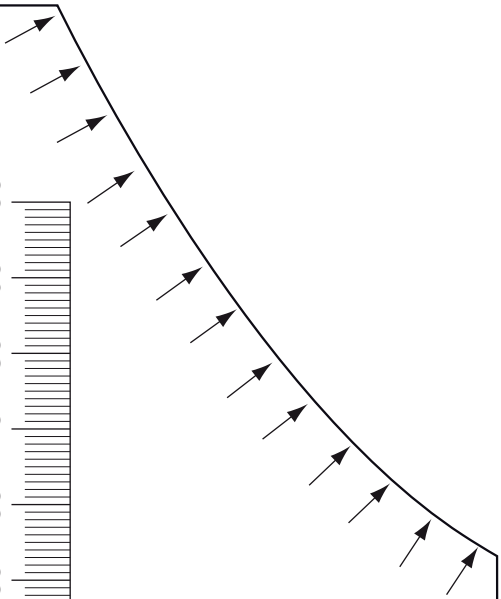
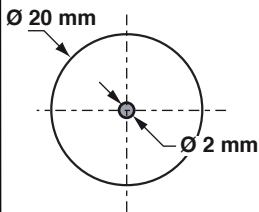

K0339





